



Thru-beam sensor (receiver)

OBE2000-R3-E1-Y302636

- Ultra-small housing design
- Improvement in machine availability with abrasion-resistant, antistatic glass front
- 45° cable outlet for maximum mounting freedom under extremely tight space constraints

Thru-beam sensor (receiver)

The nano sensor has been developed for a broad range of applications. It offers excellent durability and is exceptionally easy to install. The housing is compact and, with its 45° cable outlet, can be installed in the smallest spaces. New functional principles and functionality open up a range of new options.

Dimensions

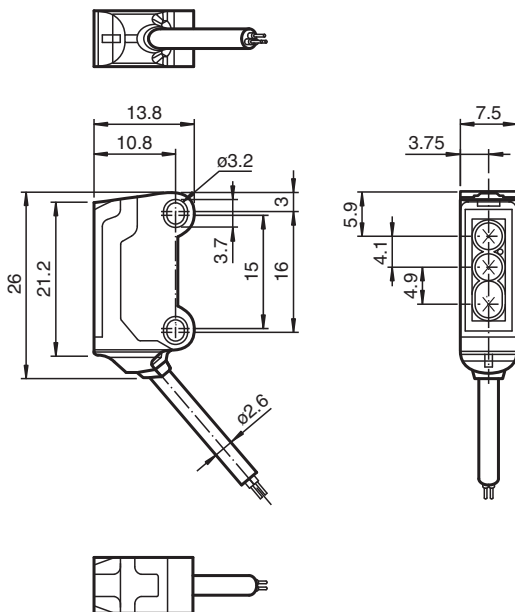

Technical Data

System components

Receiver	OBE2000-R3-E1-Y302636
----------	-----------------------

General specifications

Effective detection range	0 ... 2 m
Threshold detection range	2.5 m
Angle deviation	approx. 2°
Optical face	frontal
Ambient light limit	EN 60947-5-2 : 30000 Lux
Teach-In	deactivated

Functional safety related parameters

MTTF _d	806 a
-------------------	-------

Technical Data

Mission Time (T_M)		20 a
Diagnostic Coverage (DC)		0 %
Indicators/operating means		
Function indicator		Receiver: LED yellow, lights up when light beam is free, flashes when falling short of the stability control ; OFF when light beam is interrupted
Electrical specifications		
Operating voltage	U_B	10 ... 30 V DC , class 2
No-load supply current	I_0	Receiver: ≤ 8 mA
Output		
Switching type		NC contact
Signal output		1 NPN output, short-circuit protected, reverse polarity protected, open collector
Switching voltage		max. 30 V DC
Switching current		max. 50 mA , resistive load
Voltage drop	U_d	≤ 1.5 V DC
Switching frequency	f	approx. 100 Hz
Response time		5 ms
Conformity		
Product standard		EN 60947-5-2
Approvals and certificates		
EAC conformity		TR CU 020/2011
UL approval		cULus Recognized, Class 2 Power Source
CCC approval		CCC approval / marking not required for products rated ≤ 36 V
Ambient conditions		
Ambient temperature		-25 ... 60 °C (-13 ... 140 °F)
Storage temperature		-30 ... 70 °C (-22 ... 158 °F)
Mechanical specifications		
Housing width		7.5 mm
Housing height		26 mm
Housing depth		13.8 mm
Degree of protection		IP67
Connection		2 m fixed cable
Material		
Housing		PC/ABS and TPU
Optical face		Polycarbonate
Cable		PUR
Mass		approx. 20 g per sensor
Cable length		2 m
Factory settings		
Default setting		High gain , preset

Connection

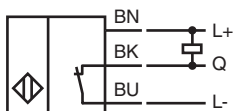

Assembly

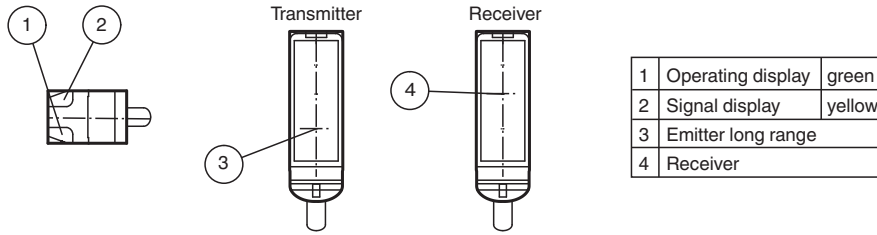

Characteristic Curve

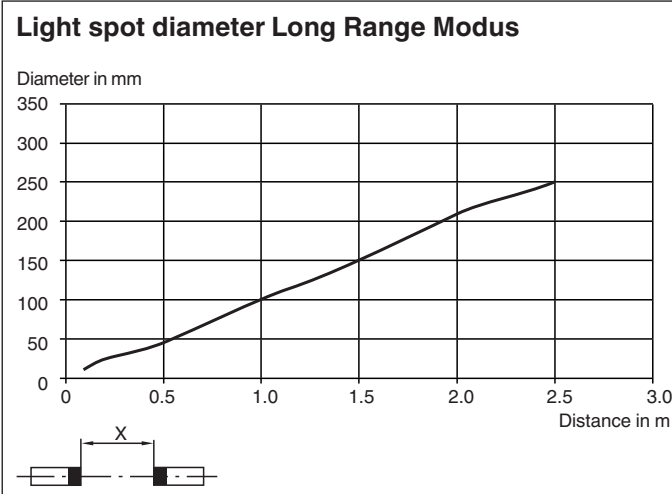
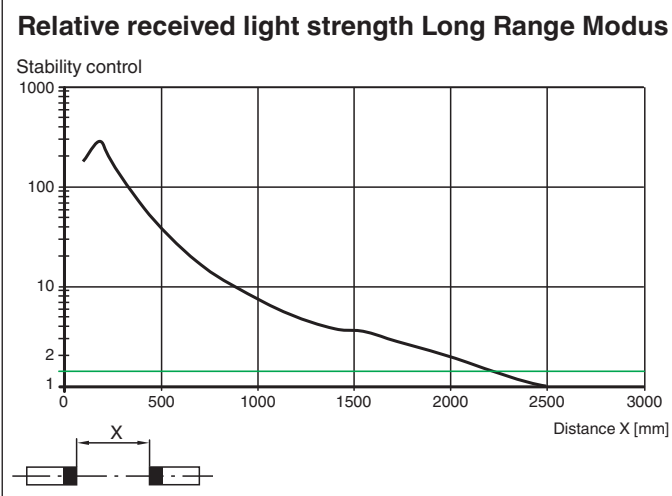
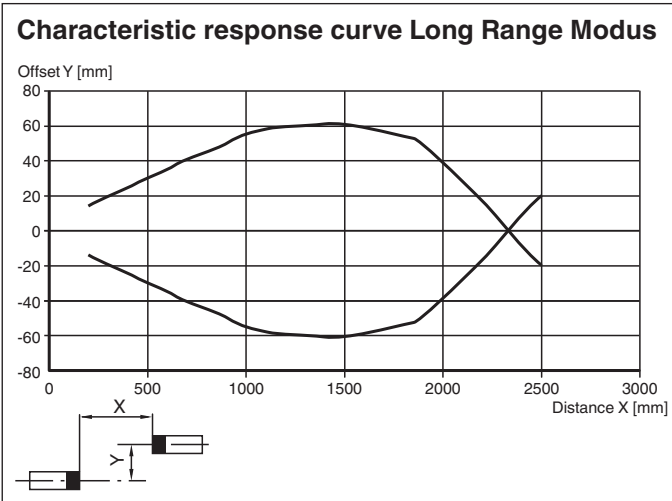

Release date: 2022-06-03 Date of issue: 2022-06-03 Filename: 302636_eng.pdf