

Absolute encoders

ENA58IL-S10C4E-1416B17-RH5

- Solid shaft
- 30 Bit multitrans
- Free of wear magnetic sampling
- High resolution and accuracy
- Mechanical compatibility with all major encoders with fieldbus interface



Function

The ENA58IL series are high precision encoders with internal magnetic sampling.

Dimensions

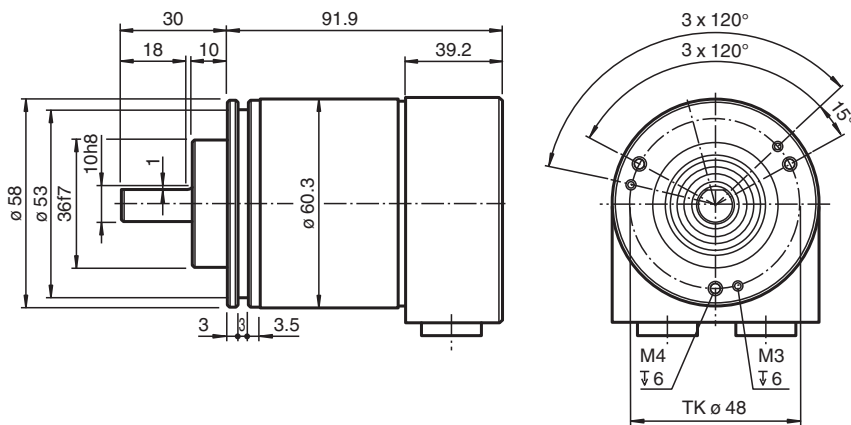

Technical Data

General specifications

Detection type	magnetic sampling
Device type	Absolute encoders
Linearity error	$\leq \pm 0.1^\circ$

Functional safety related parameters

MTTF _d	130 a at 40 °C
Mission Time (T _M)	12 a
L ₁₀	55 E+8 revolutions at 40/110 N axial/radial shaft load
Diagnostic Coverage (DC)	0 %

Electrical specifications

Operating voltage	U _B	10 ... 30 V DC
Power consumption	P ₀	approx. 3 W
Time delay before availability	t _v	< 250 ms
Output code		binary code
Code course (counting direction)		programmable, cw ascending (clockwise rotation, code course ascending) cw descending (clockwise rotation, code course descending)







Interface

Release date: 2022-12-12 Date of issue: 2022-12-12 Filename: 310873_eng.pdf

Technical Data

Interface type	PROFINET IO
Resolution	
Single turn	up to 16 Bit
Multiturn	up to 14 Bit
Overall resolution	up to 30 Bit
Transfer rate	100 MBit/s
Cycle time	≥ 1 ms
Connection	
Terminal compartment	Connection cover with radial cable outlet, with 2 threads M20 for cable glands
Standard conformity	
Degree of protection	DIN EN 60529, IP66, IP67
Climatic testing	DIN EN 60068-2-3, no moisture condensation
Emitted interference	EN 61000-6-4:2007
Noise immunity	EN 61000-6-2:2005
Shock resistance	DIN EN 60068-2-27, 100 g, 6 ms
Vibration resistance	DIN EN 60068-2-6, 10 g, 10 ... 1000 Hz
Ambient conditions	
Operating temperature	-40 ... 70 °C (-40 ... 158 °F)
Storage temperature	-40 ... 85 °C (-40 ... 185 °F)
Relative humidity	98 % , no moisture condensation
Mechanical specifications	
Material	
Housing	stainless steel V4A
Flange	stainless steel V4A
Shaft	stainless steel V4A
Mass	approx. 1000 g
Rotational speed	max. 3000 min ⁻¹
Moment of inertia	50 gcm ²
Starting torque	< 5 Ncm
Shaft load	
Axial	40 N
Radial	110 N

Accessories

	V19-G-ABG-PG9	Female connector M12 straight A-coded 8-pin, for cable diameter 5 - 8 mm, shielded, field-attachable
	9108, 6	Measuring wheel
	9109, 6	Measuring wheel for shaft diameter 6 mm
	9110, 6	Measuring wheel for shaft diameter 6 mm
	9113, 6	Measuring wheel for shaft diameter 6 mm
	MBT-36ALS	Spring-loaded mounting bracket with a diameter of 36 mm

Connection

Terminal	PWR	Port 2	Port 1
Tx +		Tx +: Transmission Data +	Tx +: Transmission Data +
Rx +		Rx +: Receive Data +	Rx +: Receive Data +
Tx -		Tx -: Transmission Data -	Tx -: Transmission Data -
Rx -		Rx -: Receive Data -	Rx -: Receive Data -
PWR+	Supply voltage+U _B		
PWR-	0 V		

Type Code

Model number

E N A 5 8 I L - S 1 0 C 4 E - 1 4 1 6 B 1 7 - R H 5

Connection type
RH5 Connection cover with radial cable outlet, with 2 threads M20 for cable glands

Interface, electric
B17 ProfiNET

Singleturn resolution
16 16 bit

Multiturn resolution
14 Multiturn rotary encoder, 14 bit

Degree of protection
E IP66, IP67

Flange
C4 Clamping flange, V4A (flange, housing material)
SA Servo flange

Shaft diameter
10 10 mm

Shaft type
S Solid shaft

Version
IL Industrial Line

Size
58 Housing diameter: 58 mm

Device type
ENA Absolute rotary encoder

Installation

Release date: 2022-12-12 Date of issue: 2022-12-12 Filename: 310873_eng.pdf

Anti-interference measures

The use of highly sophisticated microelectronics requires a consistently implemented anti-interference and wiring concept. This becomes all the more important the more compact the constructions are and the higher the demands are on the performance of modern machines.

The following installation instructions and proposals apply for "normal industrial environments". There is no ideal solution for all interfering environments.

When the following measures are applied, the encoder should be in perfect working order:

- Termination of the serial line with a 120 Ω resistor (between Receive/Transmit and Receive/Transmit) at the beginning and end of the serial line (e. g. the control and the last encoder).
- The wiring of the encoder should be laid at a large distance to energy lines which could cause interferences.
- Cable cross-section of the screen at least 4 mm².
- Cable cross-section at least 0,14 mm².
- The wiring of the screen and 0 V should be arranged radially, if and when possible.
- Do not kink or jam the cables.
- Adhere to the minimum bending radius as given in the data sheet and avoid tensile as well as shearing load.

Operating instructions

Every encoder manufactured by Pepperl+Fuchs leaves the factory in a perfect condition. In order to ensure this quality as well as a faultless operation, the following specifications have to be taken into consideration:

- Avoid any impact on the housing and in particular on the encoder shaft as well as the axial and radial overload of the encoder shaft.
- The accuracy and service life of the encoder is guaranteed only, if a suitable coupling is used.
- The operating voltage for the encoder and the follow-up device (e. g. control) has to be switched on and off simultaneously.
- Any wiring work has to be carried out with the system in a dead condition.
- The maximum operating voltages must not be exceeded. The devices have to be operated at extra-low safety voltage.

Notes on connecting the electric screening

The immunity to interference of a plant depends on the correct screening. In this field installation faults occur frequently. Often the screen is applied to one side only, and is then soldered to the earthing terminal with a wire, which is a valid procedure in LF engineering. However, in case of EMC the rules of HF engineering apply.

One basic goal in HF engineering is to pass the HF energy to earth at an impedance as low as possible as otherwise energy would discharge into the cable. A low impedance is achieved by a large-surface connection to metal surfaces.

The following instructions have to be observed:

- Apply the screen on both sides to a "common earth" in a large surface, if there is no risk of equipotential currents.
- The screen has to be passed behind the insulation and has to be clamped on a large surface below the tension relief.
- In case of cable connections to screw-type terminals, the tension relief has to be connected to an earthed surface.
- If plugs are used, metallised plugs only should be fitted (such as sub D plugs with metallised housing). Please observe the direct connection of the tension relief to the housing.

Advantage:	metallised connector, shield
relief	clamped with the strain clamp
Disadvantage:	soldering shield on

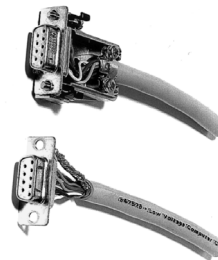

Safety instructions

Please observe the national safety and accident prevention regulations as well as the subsequent safety instructions in these operating instructions when working on encoders.

If failures cannot be remedied, the device has to be shut down and has to be secured against accidental operation.

Repairs may be carried out only by the manufacturer. Entry into and modifications of the device are not permissible.

Tighten the clamping ring only, if a shaft has been fitted in the area of the clamping ring (hollow shaft encoders).

Tighten all screws and plug connectors prior to operating the encoder.

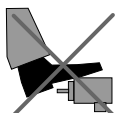

Do not stand on the encoder!

Release date: 2022-12-12 Date of issue: 2022-12-12 Filename: 310873_eng.pdf

Absolute encoders

ENA58IL-S10C4E-1416B17-RH5



Do not remachine the drive shaft!



Avoid impact!



Do not remachine the housing!