

Activator

BT65-F31-BY-EN



- High-visibility valve position display
- Protection against contamination and damage
- Captive screws for easy mounting
- Two actuation targets in two levels with 5° setting grid
- Suitable for right and left rotating drives

Activator for F31 and F31K series including protective housing

Dimensions

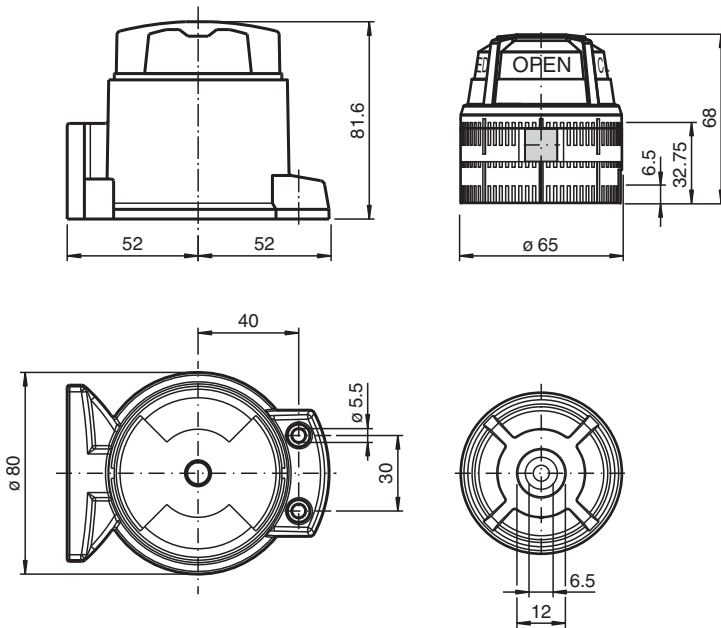

Technical Data

General specifications

Ring diameter	max. 65 mm
Spring ring height	max. 6 mm

Nominal ratings

Valve status indicator	black = CLOSED yellow = OPEN
------------------------	---------------------------------

Compliance with standards and directives

Standard conformity	
Standards	VDI / VDE 3845

Ambient conditions

Ambient temperature	-25 ... 70 °C (-13 ... 158 °F)
---------------------	--------------------------------

Mechanical specifications

Shaft diameter	≤ 49 mm
----------------	---------

Technical Data

Shaft height	20 mm and 30 mm
Mounting hole pattern	30 x 80 mm
Material	
Housing	PC
Actuator	PA
Spacer disk	PA (1 unit, 10 mm strong)
Mounting screw	Stainless steel 1.4401 / AISI 316
Activation target	Stainless steel 1.4305 / AISI 303 (integrated)
Tightening torque, fastening screws	≤ 1.5 Nm
General information	
Scope of delivery	<ul style="list-style-type: none"> 1 screw M6 x 30 1 screw M6 x 40 2 screws M5 x 12 1 Activator for F31K2 series 1 Distance disc 1 Protective Cover 2 captive Fixing screws M5 X 13