



# SMART Universal Barrier HiC2441

- 1-channel isolated barrier
- 24 V DC supply (bus powered)
- Analog input, digital input, analog output, digital output
- No configuration required, device is self-adapting
- HART transparency
- Low power dissipation
- 3-way isolation
- Up to SIL 2 acc. to IEC/EN 61508



**SIL 2**



## Function

This isolated barrier is used for intrinsic safety applications.

The device can transfer the following signals:

- as an analog input: 0/4 mA ... 20 mA
- as an analog output: 0/4 mA ... 20 mA
- as a digital input: signals from NAMUR sensors or dry contacts
- as a digital output: max. 45 mA

The device requires no configuration and adapts itself automatically to the function of the active input/output of the connected process control system.

The device permits the bi-directional pass-through of the HART communication.

The device is designed primarily for use with universal I/O cards (e. g. Honeywell Universal Process IO).

This device mounts on a HiC Termination Board.

## Application

The device is designed as intrinsically safe interface for Universal Process IO (or Universal Safety IO) by Honeywell.

## Connection

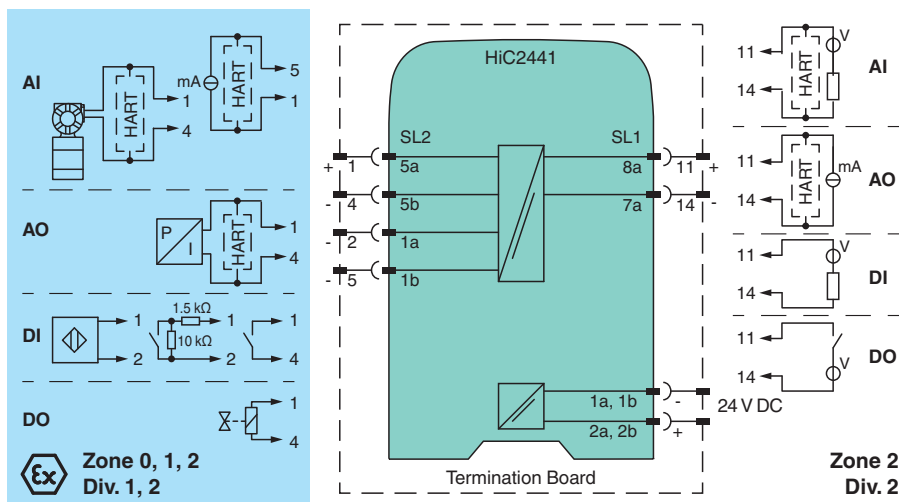

## Technical Data

### General specifications

Signal type Universal

### Functional safety related parameters

Safety Integrity Level (SIL) SIL 2

Release date: 2023-08-07 Date of issue: 2023-08-07 Filename: 315318\_eng.pdf

## Technical Data

Systematic capability (SC)		SC 2
<b>Supply</b>		
Connection		SL1: 1a, 1b(-); 2a, 2b(+)
Rated voltage	$U_r$	19 ... 30 V DC bus powered via Termination Board
Ripple		$\leq 10 \%$
Rated current	$I_r$	$\leq 30 \text{ mA}$
Power consumption		$\leq 700 \text{ mW}$
<b>Analog input</b>		
Suitable field devices		2-wire SMART transmitters, current sources
Signal		0/4 ... 20 mA , limited to approx. 40 mA (depends on control system) , reverse polarity protected
<b>Field circuit</b>		SL2: 5a(+), 5b(-) (2-wire SMART transmitter) SL2: 5a(+), 1b(-) (2-wire SMART transmitter with current source)
Voltage drop		approx. 4 V (current source)
<b>Control circuit</b>		SL1: 8a(+), 7a(-)
Supply voltage		min. 16 V at 20 mA (2-wire SMART transmitter)
Voltage		15 ... 30 V
Signal		0/4 ... 20 mA , sink mode , working voltage 15 ... 30 V
Ripple		20 mV <sub>rms</sub>
<b>Analog output</b>		
Suitable field devices		I/P converters (positioner), on-site-displays
Signal		0/4 ... 20 mA
<b>Field circuit</b>		SL2: 5a(+), 5b(-)
Load		0 ... 650 $\Omega$
Voltage		$\geq 13 \text{ V}$ at 20 mA
Ripple		20 mV <sub>rms</sub>
<b>Control circuit</b>		SL1: 8a(+), 7a(-)
Voltage		12 ... 30 V
Signal		0/4 ... 20 mA
Line fault detection		$> 100 \text{ k}\Omega$ at max. 30 V, with field wiring open
<b>Digital input</b>		
<b>Field circuit</b>		SL2: 5a(+), 1a(-) (NAMUR sensor) SL2: 5a(+), 5b(-) (dry contact)
Suitable field devices		NAMUR sensors according to IEC/EN 60947-5-6, dry contacts
Signal		0.1 ... 9 mA , sink mode
Open loop voltage		approx. 10 V DC , 1 k $\Omega$ series resistance
Signal		0.1 ... 9 mA
<b>Control circuit</b>		SL1: 8a(+), 7a(-)
Voltage		13 ... 30 V
<b>Digital output</b>		
<b>Field circuit</b>		SL2: 5a(+), 5b(-)
Suitable field devices		Solenoid Valve , audible alarm , visual alarm
Drive capability		12 V / 40 mA at 300 $\Omega$ load
Internal resistor	$R_i$	min. 240 $\Omega$
Current	$I_e$	40 mA
Voltage	$U_e$	12 V
Current limit	$I_{max}$	45 mA
Open loop voltage	$U_s$	approx. 22 V
<b>Control circuit</b>		SL1: 8a(+), 7a(-)
Voltage		1-signal: 19 ... 30 V DC 0-signal: 0 ... 5 V DC
Current		1-signal: 0 ... 45 mA, depending on the output load 0-signal: $< 0.1 \text{ mA}$ , independent of the output load
Power dissipation		1.1 W at 24 V, 300 $\Omega$ load (digital output)
<b>Transfer characteristics</b>		

Release date: 2023-08-07 Date of issue: 2023-08-07 Filename: 315318\_eng.pdf

## Technical Data

Deviation		at 20 °C (68 °F) ≤ ±20 µA incl. linearity, hysteresis and supply fluctuations at 4 ... 20 mA (analog input, analog output) ≤ ±60 µA incl. linearity, hysteresis and supply fluctuations at 0 ... 45 mA (digital output)
Influence of ambient temperature		< 2 µA/K (0 ... 70 °C (32 ... 158 °F)) < 3 µA/K (-40 ... 0 °C (-40 ... 32 °F))
Switching frequency		≤ 500 Hz with 50 % duty cycle (digital input, NAMUR sensor) ≤ 5 Hz (digital input, dry contact) ≤ 20 Hz (digital output)
Frequency range		HART: bandwidth by 0.5 V <sub>pp</sub> signal and/or 1 mA <sub>pp</sub> signal 950 ... 2500 Hz (analog input, analog output)
Settling time		≤ 20 ms (analog input, analog output) ≤ 1 ms (digital input, NAMUR sensor)
Reaction time		≤ 5 ms, turn-on/turn-off time (digital output)
<b>Galvanic isolation</b>		
Control/power supply		basic insulation according to IEC/EN 61010-1, rated insulation voltage 60 V <sub>eff</sub>
<b>Indicators/settings</b>		
Display elements		LED
Labeling		space for labeling at the front
<b>Directive conformity</b>		
Electromagnetic compatibility		
Directive 2014/30/EU		EN 61326-1:2013 (industrial locations)
<b>Conformity</b>		
Electromagnetic compatibility		NE 21:2012 For further information see system description.
Degree of protection		IEC 60529:2001
Protection against electrical shock		IEC 61010-1:2010
Input		EN 60947-5-6:2000
<b>Ambient conditions</b>		
Ambient temperature		-40 ... 70 °C (-40 ... 158 °F) Observe the temperature range limited by derating, see section derating.
Storage temperature		-40 ... 85 °C (-40 ... 185 °F)
Relative humidity		95 % non-condensing
<b>Mechanical specifications</b>		
Degree of protection		IP20
Mass		approx. 105 g
Dimensions		12.5 x 106 x 128 mm (0.5 x 4.2 x 5.1 inch) (W x H x D)
Mounting		on termination board
Coding		pin 1 and 4 trimmed For further information see system description.
<b>Data for application in connection with hazardous areas</b>		
EU-type examination certificate		TÜV 14 ATEX 153522 X
Marking		⊕ II (1)G [Ex ia Ga] IIC ⊕ II (1)D [Ex ia Da] IIIC ⊕ I (M1) [Ex ia Ma] I
<b>Supply</b>		
Maximum safe voltage	U <sub>m</sub>	250 V (Attention! The rated voltage can be lower.)
Equipment		SL2: 5a(+), 5b(-)
Voltage	U <sub>o</sub>	25.2 V
Current	I <sub>o</sub>	110 mA
Power	P <sub>o</sub>	693 mW
Internal capacitance	C <sub>i</sub>	5.7 nF
Internal inductance	L <sub>i</sub>	0 mH
Equipment		SL2: 5a(+), 1b(-)
Voltage	U <sub>i</sub>	< 28 V
Current	I <sub>i</sub>	< 115 mA
Voltage	U <sub>o</sub>	7.2 V
Current	I <sub>o</sub>	0 mA

## Technical Data

Power	$P_o$	0 mW
Internal capacitance	$C_i$	5.7 nF
Internal inductance	$L_i$	0 mH
Equipment		SL2: 5a(+), 1a(-)
Voltage	$U_o$	12.6 V
Current	$I_o$	13 mA
Power	$P_o$	41 mW
Internal capacitance	$C_i$	5.7 nF
Internal inductance	$L_i$	0 mH
Certificate		TÜV 14 ATEX 153523 X
Marking		Ⓜ II 3G Ex ec IIC T4 Gc
Galvanic isolation		
Input/Other circuits		safe electrical isolation acc. to IEC/EN 60079-11, voltage peak value 375 V
Directive conformity		
Directive 2014/34/EU		EN IEC 60079-0:2018+AC:2020 , EN 60079-11:2012 , EN 60079-7:2015+A1:2018
<b>International approvals</b>		
UL approval		E106378
Control drawing		116-0408 (cULus)
IECEX approval		
IECEX certificate		IECEX TUN 15.0004X
IECEX marking		[Ex ia Ga] IIC , [Ex ia Da] IIIC , [Ex ia Ma] I Ex ec IIC T4 Gc
<b>General information</b>		
Supplementary information		Observe the certificates, declarations of conformity, instruction manuals, and manuals where applicable. For information see <a href="http://www.pepperl-fuchs.com">www.pepperl-fuchs.com</a> .

## Assembly

### Front view

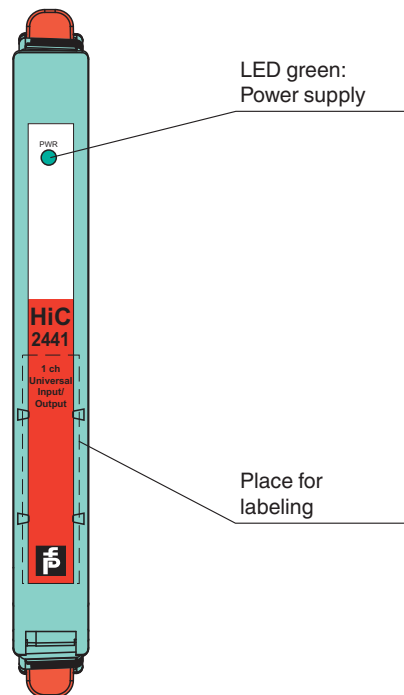

## Safety Information

The pins for this device are trimmed to polarize it according to its safety parameter. Do not change this setting!  
For further information see system manual.

## Configuration

No user configuration available for this device.

Release date: 2023-08-07 Date of issue: 2023-08-07 Filename: 315318\_eng.pdf

**Application**

**Examples**

**Analog input**

The control system must be parameterized to an active current input.

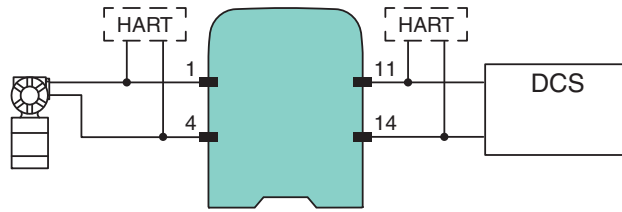

**Analog output**

The control system must be parameterized to a current output.

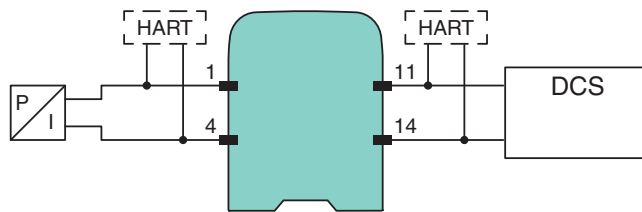

**Digital input**

The digital input of the control system must evaluate the level of a current signal.

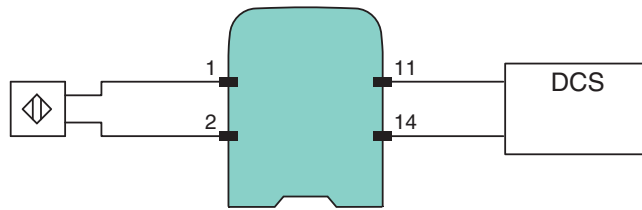

**Digital output**

The digital output of the control system must be parameterized in a way that the digital output powers actively a valve. The current which is provided by the control system is transferred directly to the valve.

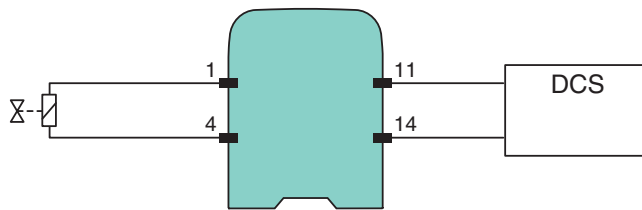

*This section does not show all connection options. For further connection options see "Connection" section.*

**Characteristic Curve**

**Fallback characteristic for digital output**

Release date: 2023-08-07 Date of issue: 2023-08-07 Filename: 315318\_eng.pdf

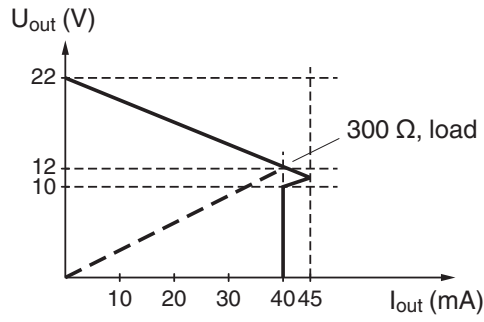

## Characteristic Curve

### Derating

