



SMART Transmitter Power Supply HiC2025A

- 1-channel isolated barrier
- 24 V DC supply (bus powered)
- Input for 2-wire SMART transmitters and current sources
- Output for 4 mA ... 20 mA or 1 V ... 5 V
- Low power dissipation
- Reduced intrinsically safe parameters
- Up to SIL 2 (SC 3) acc. to IEC/EN 61508



Function

This isolated barrier is used for intrinsic safety applications. The device supplies 2-wire transmitters in the hazardous area, and can also be used with current sources. It transfers the analog input signal to the safe area as an isolated current value. Bi-directional communication is supported for SMART transmitters that use current modulation to transmit data and voltage modulation to receive data. The output is selected as a current source, current sink, or voltage source via DIP switches. This device mounts on a HiC Termination Board.

Application

The device supports the following SMART protocols:

- HART
- BRAIN

Connection

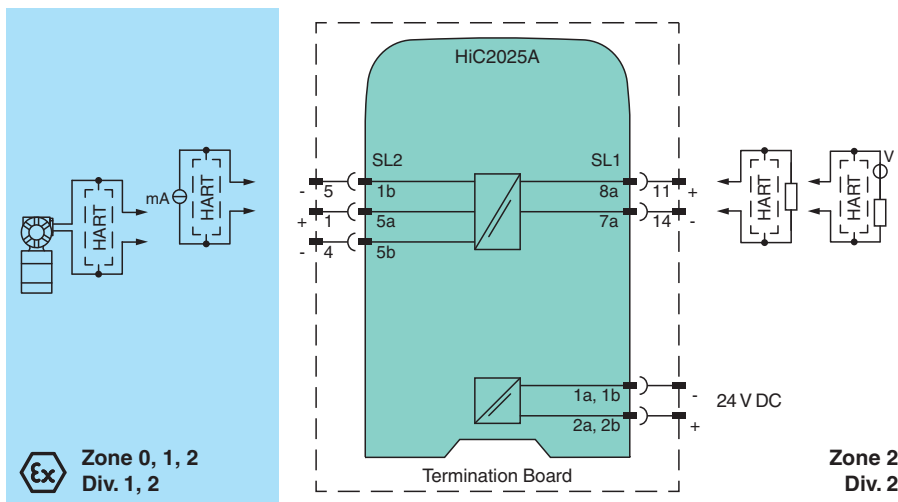

Technical Data

General specifications

| | |
|-------------|--------------|
| Signal type | Analog input |
|-------------|--------------|

Release date: 2023-06-01 Date of issue: 2023-06-01 Filename: 321425_eng.pdf

Technical Data

| Functional safety related parameters | | |
|--------------------------------------|-------|---|
| Safety Integrity Level (SIL) | | SIL 2 |
| Systematic capability (SC) | | SC 3 |
| Supply | | |
| Connection | | SL1: 1a, 1b(-); 2a, 2b(+) |
| Rated voltage | U_r | 19 ... 30 V DC bus powered via Termination Board |
| Ripple | | $\leq 10 \%$ |
| Rated current | I_r | $\leq 45 \text{ mA}$ at 24 V and 20 mA source mode output |
| Power dissipation | | $\leq 800 \text{ mW}$ |
| Power consumption | | $\leq 1.1 \text{ W}$ |
| Input | | |
| Connection side | | field side |
| Connection | | SL2: 5a(+), 1b(-); 5a(+), 5b(-) |
| Input signal | | 4 ... 20 mA limited to approx. 26 mA |
| Voltage drop | | approx. 5 V on SL2: 5a(+), 1b(-) |
| Available voltage | | $\geq 14.7 \text{ V}$ at 20 mA $\geq 18 \text{ V}$ at 4 mA on SL2: 5a(+), 5b(-) |
| Output | | |
| Connection side | | control side |
| Connection | | SL1: 8a(+), 7a(-) |
| Load | | 0 ... 350 Ω (source mode) |
| Output signal | | source mode: 4 ... 20 mA or 1 ... 5 V (internal resistor: 250 Ω , 0.1 %) sink mode: 4 ... 20 mA, operating voltage 10 ... 30 V For additional internal or external loads the voltage drop has to be considered, e. g. 250 Ω x 20 mA = 5 V. |
| Ripple | | 20 mV _{rms} |
| Transfer characteristics | | |
| Deviation | | at 20 °C (68 °F) $< 0.1 \%$ of full scale, incl. non-linearity and hysteresis (source mode and sink mode 4 ... 20 mA) $\leq \pm 0.2 \%$ incl. non-linearity and hysteresis (source mode 1 ... 5 V) |
| Influence of ambient temperature | | $< 2 \mu\text{A/K}$ (-20 ... 70 °C (-4 ... 158 °F)); $< 4 \mu\text{A/K}$ (-40 ... -20 °C (-40 ... -4 °F)) (source mode and sink mode 4 ... 20mA) $< 0.5 \text{ mV/K}$ (-20 ... 70 °C (-4 ... 158 °F)); $< 1 \text{ mV/K}$ (-40 ... -20 °C (-40 ... -4 °F)) (source mode 1...5 V) |
| Frequency range | | field side into the control side: bandwidth with 0.5 V _{pp} signal 0 ... 3 kHz (-3 dB) control side into the field side: bandwidth with 0.5 V _{pp} signal 0 ... 3 kHz (-3 dB) |
| Settling time | | $\leq 50 \text{ ms}$ |
| Rise time/fall time | | $\leq 10 \text{ ms}$ |
| Galvanic isolation | | |
| Input/Output | | safe electrical isolation acc. to IEC/EN 60079-11, voltage peak value 375 V |
| Input/power supply | | safe electrical isolation acc. to IEC/EN 60079-11, voltage peak value 375 V |
| Output/power supply | | basic insulation according to IEC/EN 61010-1, rated insulation voltage 60 V _{eff} |
| Indicators/settings | | |
| Display elements | | LED |
| Control elements | | DIP switch |
| Configuration | | via DIP switches |
| Labeling | | space for labeling at the front |
| Directive conformity | | |
| Electromagnetic compatibility | | |
| Directive 2014/30/EU | | EN 61326-1:2013 (industrial locations) |
| Conformity | | |
| Electromagnetic compatibility | | NE 21:2017 EN 61326-3-2:2018 For further information see system description. |
| Degree of protection | | IEC 60529:2001 |
| Protection against electrical shock | | UL 61010-1:2012 |

Technical Data

| | |
|--|---|
| Ambient conditions | |
| Ambient temperature | -40 ... 70 °C (-40 ... 158 °F) |
| Mechanical specifications | |
| Degree of protection | IP20 |
| Mass | approx. 100 g |
| Dimensions | 12.5 x 106 x 128 mm (0.5 x 4.2 x 5.1 inch) (W x H x D) |
| Mounting | on termination board |
| Coding | pin 2 and 3 trimmed For further information see system description. |
| Data for application in connection with hazardous areas | |
| EU-type examination certificate | CESI 06 ATEX 017 |
| Marking | ⊕ II (1)G [Ex ia Ga] IIC ⊕ II (1)D [Ex ia Da] IIIC ⊕ I (M1) [Ex ia Ma] I |
| Input | Ex ia |
| Supply | |
| Maximum safe voltage | U_m 250 V AC (Attention! U_m is no rated voltage.) |
| Equipment | SL2: 5a(+), 5b(-) |
| Voltage | U_o 25.2 V |
| Current | I_o 93 mA |
| Power | P_o 586 mW |
| Internal capacitance | C_i 5.7 nF |
| Internal inductance | L_i negligible |
| Equipment | SL2: 5a(+), 1b(-) |
| Voltage | U_i 30 V |
| Current | I_i 128 mA |
| Voltage | U_o 1 V |
| Current | I_o 100 mA |
| Power | P_o 25 mW |
| Internal capacitance | C_i 5.7 nF |
| Internal inductance | L_i negligible |
| Certificate | CESI 19 ATEX 027 X |
| Marking | ⊕ II 3G Ex ec IIC T4 Gc |
| Directive conformity | |
| Directive 2014/34/EU | EN 60079-0:2012+A11:2013 , EN 60079-11:2012 , EN 60079-7:2015 |
| International approvals | |
| FM approval | |
| FM certificate | FM 19 US 0122 X , FM 19 CA 0065 X |
| Control drawing | 116-0470 (cFMus) |
| UL approval | |
| Control drawing | 116-0458 (cULus) |
| IECEx approval | |
| IECEx certificate | IECEx CES 06.0002X |
| IECEx marking | [Ex ia Ga] IIC , [Ex ia Da] IIIC , [Ex ia Ma] I Ex ec IIC T4 Gc |
| General information | |
| Supplementary information | Observe the certificates, declarations of conformity, instruction manuals, and manuals where applicable. For information see www.pepperl-fuchs.com . |

Assembly

Front view

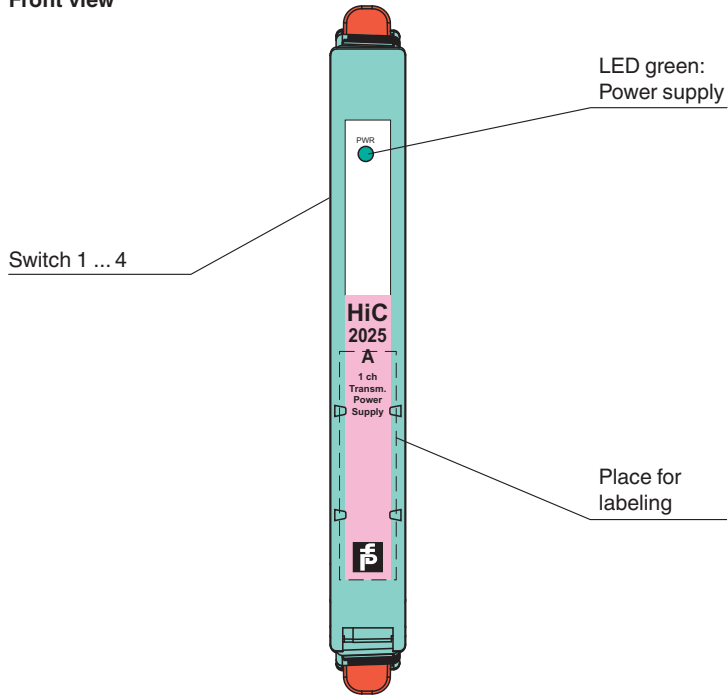

Configuration

Configure the device in the following way:

- Push the red Quick Lok Bars on each side of the device in the upper position.
- Remove the device from termination board.
- Set the switches according to the figure in the **Configuration** section.

Note

The pins for this device are trimmed to polarize it according to its safety parameters. Do not change the setting. For further information see system description.

Configuration

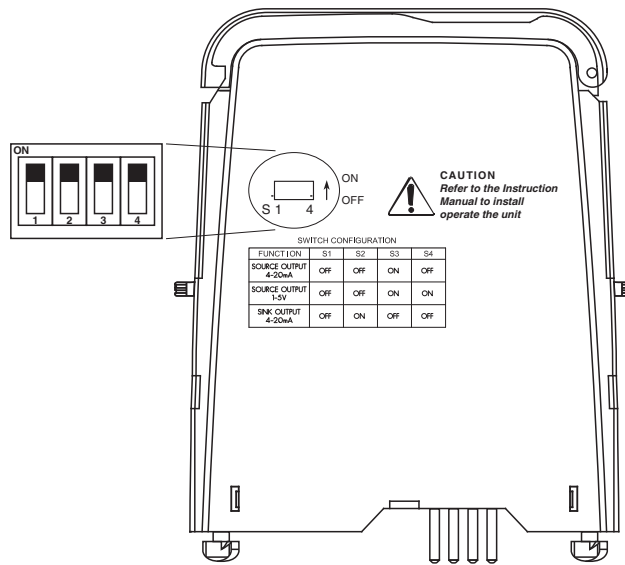

Switch position

| Function | S1 | S2 | S3 | S4 |
|-------------------------------|-----|-----|-----|-----|
| Current source 4 mA ... 20 mA | OFF | OFF | ON | OFF |
| Voltage source 1 V ... 5 V | OFF | OFF | ON | ON |
| Current sink 4 mA ... 20 mA | OFF | ON | OFF | OFF |

Factory setting: current source 4 mA ... 20 mA

Release date: 2023-06-01 Date of issue: 2023-06-01 Filename: 321425_eng.pdf