



SMART Transmitter Power Supply KCD2-STC-Ex1.ES.SP

- 1-channel isolated barrier
- 24 V DC supply (Power Rail)
- Input for 2-wire SMART transmitters and current sources
- Output for 4 mA ... 20 mA or 1 V ... 5 V
- Sink or source mode
- Line fault detection (LFD)
- Housing width 12.5 mm
- Connection via spring terminals with push-in connection technology
- Up to SIL 3 acc. to IEC/EN 61508



Function

This isolated barrier is used for intrinsic safety applications. The device supplies 2-wire transmitters in the hazardous area, and can also be used with current sources. The device transfers the analog input signal to the non-hazardous area as an isolated current value. Bi-directional communication is supported for SMART transmitters that use current modulation to transmit data and voltage modulation to receive data. The output is selected as a current source, current sink, or voltage source via DIP switches. A fault is signaled by LEDs and a separate collective error message output. Test sockets for the connection of HART communicators are integrated into the terminals of the device.

Application

The device supports the following SMART protocols:

- HART

Connection

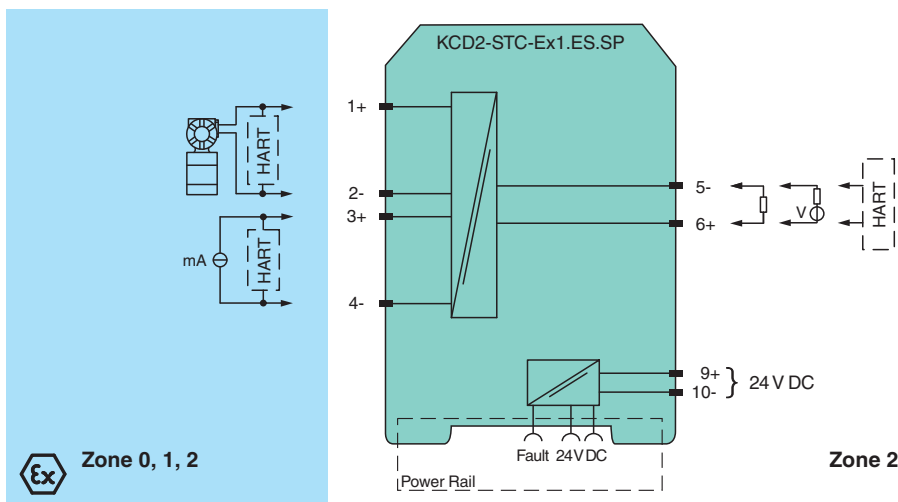

Technical Data

General specifications

Signal type Analog input

Functional safety related parameters

Safety Integrity Level (SIL) SIL 3
Systematic capability (SC) SC 3

Technical Data

Supply		
Connection		Power Rail or terminals 9+, 10-
Rated voltage	U_r	19 ... 30 V DC
Ripple		$\leq 10 \%$
Rated current	I_r	$\leq 50 \text{ mA}$
Power dissipation		$\leq 800 \text{ mW}$
Power consumption		$\leq 1.2 \text{ W}$
Input		
Connection side		field side
Connection		terminals 1+, 2-; 3+, 4-
Input signal		4 ... 20 mA , limited to approx. 27 mA reverse polarity protected
Line fault detection		downscaling $\leq 3 \text{ mA}$; upscaling $\geq 22 \text{ mA}$
Voltage drop		approx. 5 V on terminals 3+, 4-
Available voltage		$\geq 15 \text{ V}$ at 20 mA terminals 1+, 2-
Output		
Connection side		control side
Connection		terminals 5-, 6+
Load		0 ... 300 Ω (source mode)
Output signal		source mode: 4 ... 20 mA or 1 ... 5 V (internal resistor: 250 Ω , 0.1 %) sink mode: 4 ... 20 mA, operating voltage 16 ... 28 V For additional internal or external loads the voltage drop has to be considered, e. g. 250 Ω x 20 mA = 5 V.
Ripple		20 mV _{rms}
Fault indication output		
Output type		fault bus signal , open collector transistor
Transfer characteristics		
Deviation		at 20 °C (68 °F) $\leq \pm 20 \mu\text{A}$ incl. calibration, linearity, hysteresis, loads and supply voltage fluctuations (source mode and sink mode 4 ... 20 mA) $\leq 10 \text{ mV}$ incl. calibration, linearity, hysteresis and fluctuations of supply voltage (source mode 1 ... 5 V)
Influence of ambient temperature		$< 2 \mu\text{A/K}$ (0 ... 70 °C (32 ... 158 °F)); $< 4 \mu\text{A/K}$ (-20 ... 0 °C (-4 ... 32 °F)) (source mode and sink mode 4 ... 20 mA) $< 0.5 \text{ mV/K}$ (0 ... 70 °C (32 ... 158 °F)); $< 1 \text{ mV/K}$ (-20 ... 0 °C (-4 ... 32 °F)) (source mode 1 ... 5 V)
Frequency range		field side into the control side: bandwidth with 1 mA _{pp} signal 0 ... 3 kHz (-3 dB) control side into the field side: bandwidth with 0.5 V _{pp} signal 0 ... 3 kHz (-3 dB)
Settling time		$\leq 200 \text{ ms}$
Rise time/fall time		$\leq 20 \text{ ms}$
Galvanic isolation		
Input/Output		safe electrical isolation acc. to IEC/EN 60079-11, voltage peak value 375 V
Input/power supply		safe electrical isolation acc. to IEC/EN 60079-11, voltage peak value 375 V
Output/power supply		Basic isolation acc. to EN 61010-1 rated insulation voltage $\leq 50 \text{ V}$
Indicators/settings		
Display elements		LEDs
Control elements		DIP switch
Configuration		via DIP switches
Labeling		space for labeling at the front
Directive conformity		
Electromagnetic compatibility		
Directive 2014/30/EU		EN 61326-1:2013 (industrial locations)
Conformity		
Electromagnetic compatibility		NE 21:2017 For further information see system description.
Degree of protection		IEC 60529:2001
Ambient conditions		
Ambient temperature		-20 ... 70 °C (-4 ... 158 °F)

Technical Data





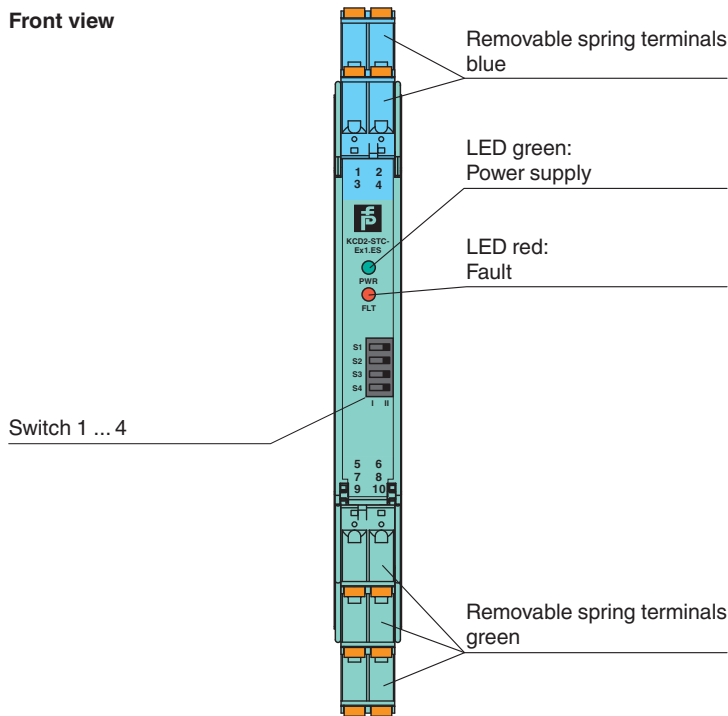

Mechanical specifications		
Degree of protection		IP20
Connection		spring terminals
Mass		approx. 100 g
Dimensions		12.5 x 119 x 114 mm (0.5 x 4.7 x 4.5 inch) (W x H x D) , housing type A2
Mounting		on 35 mm DIN mounting rail acc. to EN 60715:2001
Data for application in connection with hazardous areas		
EU-type examination certificate		CESI 10 ATEX 071
Marking		⊕ II (1)G [Ex ia Ga] IIC ⊕ II (1)D [Ex ia Da] IIIC ⊕ I (M1) [Ex ia Ma] I
Input		Ex ia
Supply		
Maximum safe voltage	U_m	253 V AC (Attention! U_m is no rated voltage.)
Equipment		terminals 1+, 2-
Voltage	U_o	25.2 V
Current	I_o	100 mA
Power	P_o	630 mW
Internal capacitance	C_i	5.7 nF
Internal inductance	L_i	negligible
Equipment		terminals 3+, 4-
Voltage	U_i	< 30 V
Current	I_i	< 128 mA
Voltage	U_o	7.2 V
Current	I_o	100 mA
Power	P_o	25 mW
Internal capacitance	C_i	5.7 nF
Internal inductance	L_i	negligible
Certificate		CESI 19 ATEX 005 X
Marking		⊕ II 3G Ex ec IIC T4 Gc
Directive conformity		
Directive 2014/34/EU		EN 60079-0:2012+A11:2013 , EN 60079-11:2012 , EN 60079-7:2015
International approvals		
UL approval		E106378
Control drawing		116-0378 (cULus)
IECEx approval		
IECEx certificate		IECEx CES 11.0001X
IECEx marking		[Ex ia Ga] IIC , [Ex ia Da] IIIC , [Ex ia Ma] I Ex ec IIC T4 Gc
General information		
Supplementary information		Observe the certificates, declarations of conformity, instruction manuals, and manuals where applicable. For information see www.pepperl-fuchs.com .

Assembly





Front view



Matching System Components

	KFD2-EB2	Power Feed Module
	UPR-03	Universal Power Rail with end caps and cover, 3 conductors, length: 2 m
	UPR-03-M	Universal Power Rail with end caps and cover, 3 conductors, length: 1,6 m
	UPR-03-S	Universal Power Rail with end caps and cover, 3 conductors, length: 0.8 m
	K-DUCT-BU	Profile rail, wiring comb field side, blue
	K-DUCT-BU-UPR-03	Profile rail with UPR-03- * insert, 3 conductors, wiring comb field side, blue

Accessories

	KC-CTT-3GN2BU	Terminal block for KC modules, 2-pin spring terminal, with test sockets
	KC-CTT-5BU	Terminal block for KC modules, 2-pin spring terminal, with test sockets, blue
	KC-CTT-5GN	Terminal block for KC modules, 2-pin spring terminal, with test sockets, green
	KF-CP	Red coding pins, packaging unit: 20 x 6

Release date: 2023-06-01 Date of issue: 2023-06-01 Filename: 322428_eng.pdf

Configuration

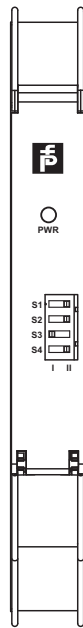

Output switch settings

Mode of operation	S1	S2	S3	S4
Current source output 4 ... 20 mA	II	II	I	II
Voltage source output 1 ... 5 V	II	II	I	I
Current sink output 4 ... 20 mA	II	I	II	II

Factory setting: current source output 4 ... 20 mA

Characteristic Curve

Transfer characteristic

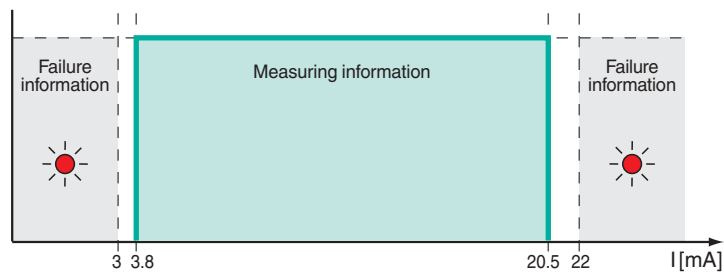

Release date: 2023-06-01 Date of issue: 2023-06-01 Filename: 322428_eng.pdf