



# SMART Current Driver HiC2031ES

- 1-channel isolated barrier
- 24 V DC supply (bus powered)
- Current output up to 650  $\Omega$  load
- HART-IP and valve positioner
- Low power dissipation
- Line fault detection (LFD)
- Up to SIL 3 acc. to IEC/EN 61508



**SIL 3**



## Function

This isolated barrier is used for intrinsic safety applications.

The device repeats the input signal from a control system to drive HART I/P converters, electrical valves, and positioners located in a hazardous area.

Digital signals are superimposed on the analog values at the field side or control side and are transferred bi-directionally.

An open or short field circuit presents a high impedance to the control side to allow alarm conditions to be monitored by the control system.

Line fault detection of the field circuit is indicated by a red LED and an output on the fault bus.

This device mounts on a HiC termination board.

## Connection

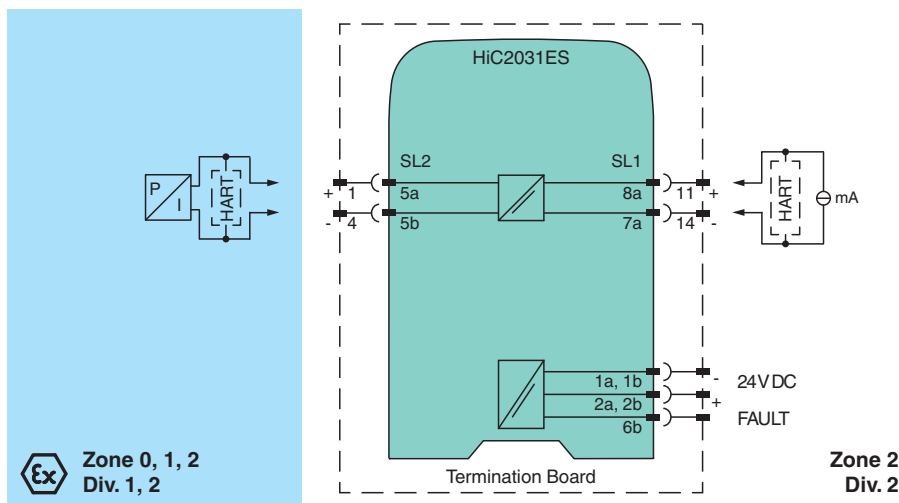

## Technical Data

General specifications	
Signal type	Analog output
Functional safety related parameters	
Safety Integrity Level (SIL)	SIL 3
Supply	
Connection	SL1: 1a(-), 1b(-); 2a(+), 2b(+)
Rated voltage	$U_r$ 19 ... 30 V DC bus powered via Termination Board
Ripple	$\leq 10$ %
Rated current	$I_r$ $\leq 33$ mA at 24 V
Power dissipation	$\leq 700$ mW at 20 mA and 500 $\Omega$ load

Release date: 2023-08-10 Date of issue: 2023-08-10 Filename: 70101789\_eng.pdf

## Technical Data

Power consumption	≤ 800 mW
<b>Input</b>	
Connection side	control side
Connection	SL1: 8a(+), 7a(-)
Input signal	4 ... 20 mA , limited to approx. 25 mA
Input voltage	open loop voltage of the control system < 30 V
Voltage drop	approx. 6 V at 20 mA
Input resistance	> 100 kΩ, with field wiring open or < 50 Ω
<b>Output</b>	
Connection side	field side
Connection	SL2: 5a(+), 5b(-)
Voltage	≥ 13 V at 20 mA
Current	4 ... 20 mA
Load	100 ... 650 Ω
Ripple	20 mV rms
Line fault detection	field wiring open or < 50 Ω and test current < 2 mA
<b>Fault indication output</b>	
Connection	SL1: 6b
Output type	open collector transistor (internal fault bus)
<b>Transfer characteristics</b>	
Deviation	at 20 °C (68 °F), 4 ... 20 mA < 0.1 % of full scale, incl. non-linearity and hysteresis
Influence of ambient temperature	< 2 μA/K (-20 ... 70 °C (-4 ... 158 °F)); < 4 μA/K (-40 ... -20 °C (-40 ... -4 °F))
Frequency range	field side into the control side: bandwidth with 0.5 V <sub>pp</sub> signal 0 ... 3 kHz (-3 dB) control side into the field side: bandwidth with 1 mA <sub>pp</sub> signal 0 ... 3 kHz (-3 dB)
Rise time	10 to 90 % ≤ 10 ms
<b>Galvanic isolation</b>	
Input/Output	safe electrical isolation acc. to IEC/EN 60079-11, voltage peak value 375 V
Input/power supply	basic insulation according to IEC/EN 61010-1, rated insulation voltage 60 V <sub>eff</sub>
Output/power supply	safe electrical isolation acc. to IEC/EN 60079-11, voltage peak value 375 V
<b>Indicators/settings</b>	
Display elements	LEDs
Labeling	space for labeling at the front
<b>Directive conformity</b>	
Electromagnetic compatibility	
Directive 2014/30/EU	EN 61326-1:2013 (industrial locations)
<b>Conformity</b>	
Electromagnetic compatibility	NE 21:2017 EN 61326-3-2:2018 For further information see system description.
Degree of protection	IEC 60529:2001
Protection against electrical shock	UL 61010-1:2012
<b>Ambient conditions</b>	
Ambient temperature	-40 ... 70 °C (-40 ... 158 °F)
<b>Mechanical specifications</b>	
Degree of protection	IP20
Mass	approx. 100 g
Dimensions	12.5 x 106 x 128 mm (0.5 x 4.2 x 5.1 inch) (W x H x D)
Mounting	on termination board
Coding	pin 1 and 3 trimmed For further information see system description.
<b>Data for application in connection with hazardous areas</b>	
EU-type examination certificate	CESI 20 ATEX 007 X
Marking	Ⓢ II (1)G [Ex ia Ga] IIC Ⓢ II (1)D [Ex ia Da] IIIC Ⓢ I (M1) [Ex ia Ma] I

Release date: 2023-08-10 Date of issue: 2023-08-10 Filename: 70101789\_eng.pdf

**Technical Data**

Output	Ex ia	
Supply		
Maximum safe voltage	$U_m$	250 V AC (Attention! $U_m$ is no rated voltage.)
Equipment		SL2: 5a(+), 5b(-)
Voltage	$U_o$	25.2 V
Current	$I_o$	100 mA
Power	$P_o$	630 mW
Internal capacitance	$C_i$	5.7 nF
Internal inductance	$L_i$	negligible
Certificate		CESI 20 ATEX 008 X
Marking		Ⓜ II 3G Ex ec IIC T4 Gc
Directive conformity		
Directive 2014/34/EU		EN IEC 60079-0:2018 , EN 60079-11:2012 , EN 60079-7:2015
<b>International approvals</b>		
UL approval		E106378
Control drawing		116-0472 (cULus)
IECEx approval		
IECEx certificate		IECEx CES 20.0008X
IECEx marking		[Ex ia Ga] IIC , [Ex ia Da] IIIC , [Ex ia Ma] I Ex ec IIC T4 Gc
<b>General information</b>		
Supplementary information		Observe the certificates, declarations of conformity, instruction manuals, and manuals where applicable. For information see <a href="http://www.pepperl-fuchs.com">www.pepperl-fuchs.com</a> .

**Assembly**

Front view

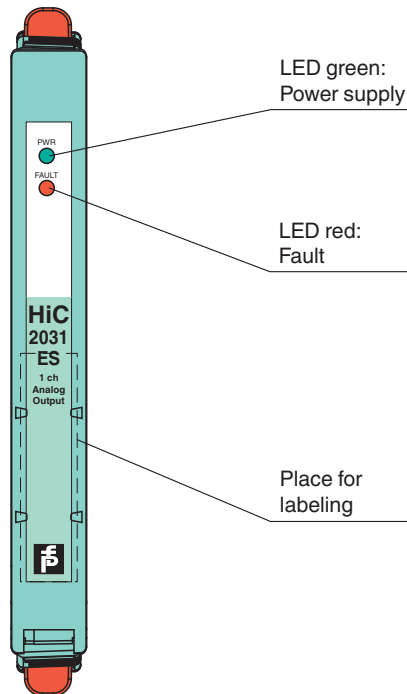

**Safety Information**

The pins for this device are trimmed to polarize it according to its safety parameter. Do not change this setting!  
For further information see system manual.

Release date: 2023-08-10 Date of issue: 2023-08-10 Filename: 70101789\_eng.pdf