



# Power Supply

## PS1000-A6-24.5

- 100 V AC to 240 V AC wide-range input
- Output 24 V DC, 5 A, 120 W, 1-phase
- Housing width 32 mm
- Efficiency up to 94.3 %
- Minimal inrush current surge
- DC OK relay contact
- Suitable for Zone 2/Div. 2 mounting



### Function

The device is used to supply field devices with 24 V DC and 5 A. The device has a power reserve of 20 % included, which may even be used continuously at temperatures up to +45 °C. The output voltage can be adjusted via a potentiometer. The device status is indicated by an LED. The device has a relay contact output for remote monitoring. The device is mounted on a 35 mm DIN mounting rail according to EN 60715.

### Connection

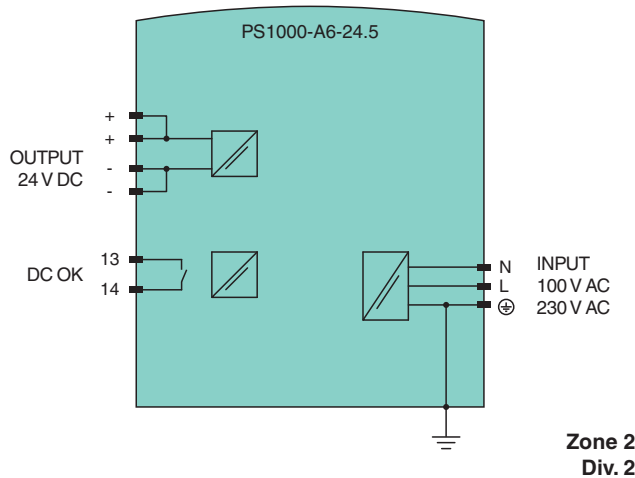

### Technical Data

Electrical specifications	
Efficiency	93.6 % at 120 V AC 94.3 % at 230 V AC
Power dissipation	8.2 W at 120 V AC 7.3 W at 230 V AC
Input	
Voltage range	100 ... 240 V AC (-15 %/+10 %), 50 ... 60 Hz (±6 %) 110 ... 150 V DC (±20 %)
Current	1.09 A at 120 V AC 0.6 A at 230 V AC 1.21 A at 110 V DC for lower output currents see technical information

Release date: 2023-11-30 Date of issue: 2023-11-30 Filename: 70103517\_eng.pdf

## Technical Data

Inrush current		5 A peak at 120 V AC and ambient temperature 40 °C (104 °F) 6 A peak at 230 V AC and ambient temperature 40 °C (104 °F) or ambient temperature 25 °C (77 °F)
Capacity factor		0.98 at 120 V AC 0.91 at 230 V AC
<b>Output</b>		
Rated voltage	$U_r$	24 V DC
Voltage range		24 ... 28 V DC factory setting: 24.1 V
Rated current	$I_r$	5 A
Current		6 ... 5.1 A at ambient temperature < 45 °C (113 °F) 5 ... 4.3 A at ambient temperature 60 °C (140 °F) 3.8 ... 3.2 A at ambient temperature 70 °C (158 °F) linear power derating see technical information
Power		120 W
Ripple		max. 50 mV <sub>pp</sub>
Hold-up time		35 ms at 120 V AC 35 ms at 230 V AC
Overload behavior		continuous current at output voltage > 13 V DC Hiccup behaviour at output voltage < 13 V DC
Short-circuit current		typ. 15 A for 12 ms or 3 A <sub>rms</sub> continuous current
Voltage limitation		typ. 30.5 V DC max. 32 V DC
<b>Fault indication output</b>		
Connection		terminals 13, 14
Output type		relay contact DC OK - contact is closed if the output voltage is > 90 % of the adjusted output voltage
Contact loading		max. 60 V DC/0.3 A ; 30 V DC/1 A ; 30 V AC/0.5 A resistive load min. 1 mA at 5 V DC
<b>Galvanic isolation</b>		
Input/Output		SELV/PELV
<b>Indicators/settings</b>		
Display elements		LED green: status DC OK - LED lights up if the output voltage is > 90 % of the adjusted output voltage
Control elements		potentiometer
Configuration		setting of the output voltage via potentiometer
<b>Directive conformity</b>		
Electromagnetic compatibility		
Directive 2014/30/EU		IEC/EN 61000-6-1 , IEC/EN 61000-6-2 , IEC/EN 61000-6-3 , IEC/EN 61000-6-4 , IEC/EN 61000-3-2 , IEC/EN 61000-3-3
Low voltage		
Directive 2014/35/EU		EN 61010-1
RoHS		
Directive 2011/65/EU (RoHS)		IEC/EN 63000:2019
<b>Conformity</b>		
Degree of protection		EN 60529
Shock resistance		EN 60068-2-27
Vibration resistance		EN 60068-2-6
<b>Ambient conditions</b>		
Ambient temperature		-25 ... 70 °C (-13 ... 158 °F) , see technical information
Storage temperature		-40 ... 85 °C (-40 ... 185 °F)
Relative humidity		5 ... 95 % , noncondensing
Shock resistance		20 g , 11 ms or 30 g , 6 ms
Vibration resistance		2 ... 17.8 Hz : ± 1.6 mm , 17.8 ... 500 Hz : 2 g
<b>Mechanical specifications</b>		
Housing material		aluminum alloy , galvanized steel
Degree of protection		IP20

## Technical Data

<b>Connection</b>	
Input/Output	screw terminals conductor cross section: max. 6 mm <sup>2</sup> (AWG 20-10) cable diameter: max. 2.8 mm, wire end ferrules included stripped insulation length: 7 mm tightening torque: max. 1 Nm
Relay contact output	spring terminals with push-in connection technology conductor cross section: max. 1.5 mm <sup>2</sup> (AWG 24-16) cable diameter: max. 1.6 mm, wire end ferrules included stripped insulation length: 7 mm
Mass	approx. 440 g
Dimensions	32 x 124 x 102 mm (W x H x D) , without DIN mounting rail
Mounting	on 35 mm DIN mounting rail acc. to EN 60715:2001
<b>Data for application in connection with hazardous areas</b>	
ATEX approval	
ATEX certificate	EPS 19 ATEX 1201 X
ATEX marking	Ⓔ II 3G Ex ec nC II T4 Gc
Directive conformity	
Directive 2014/34/EU	EN 60079-0:2018 , EN 60079-7:2015+A1:2018 , EN 60079-15:2010
<b>International approvals</b>	
UL approval	E350173 , E223176
IECEX approval	
IECEX certificate	IECEX EPS 20.0058X
IECEX marking	Ex ec nC IIC T4 Gc
Standards	IEC 60079-0:2017 , IEC 60079-7:2017 , IEC 60079-15:2017
<b>General information</b>	
Supplementary information	Observe the certificates, declarations of conformity, instruction manuals, and manuals where applicable. For information see <a href="http://www.pepperl-fuchs.com">www.pepperl-fuchs.com</a> .

## Assembly

### Front view

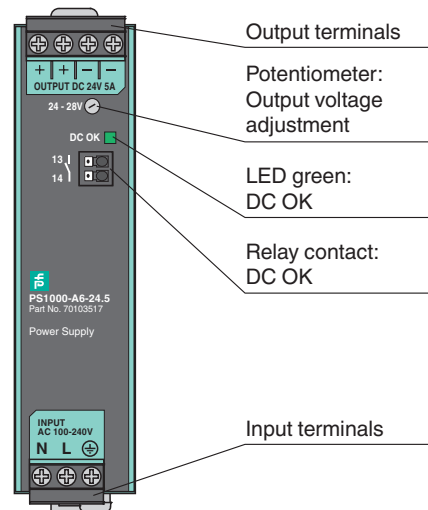

## Installation Conditions

Mount the device on the DIN mounting rail so that the input terminals are located on the bottom of the device.

This device is designed for convection cooling and does not require an external ventilator. Do not obstruct airflow. Do not cover the ventilation grid by more than 15 %, e. g. cable ducts.

If you load the device with more than 50 % of the rated power permanently keep the following mounting distances:

- 40 mm above
- 20 mm below
- 5 mm on the left and right side

Increase this distance to 15 mm if the adjacent device is a heat source, e. g. another power supply.