



Power Supply

PS1000-A6-12.16

- 100 V AC to 240 V AC wide-range input
- Output 12 V DC, 16 A, 192 W, 1-phase
- Housing width 39 mm
- Efficiency up to 94.3 %
- Minimal inrush current surge
- Remote control for ON/OFF
- DC OK relay contact
- Suitable for Zone 2/Div. 2 mounting



Function

The device is used to supply field devices with 12 V DC and 16 A.
 The device has a power reserve of 20 % included, which may even be used continuously at temperatures up to +45 °C.
 The output voltage can be adjusted via a potentiometer. The device status is indicated by an LED.
 The device has a relay contact output for remote monitoring.
 The device has a connection for switching off the device via a remote control.
 The device is mounted on a 35 mm DIN mounting rail according to EN 60715.

Connection

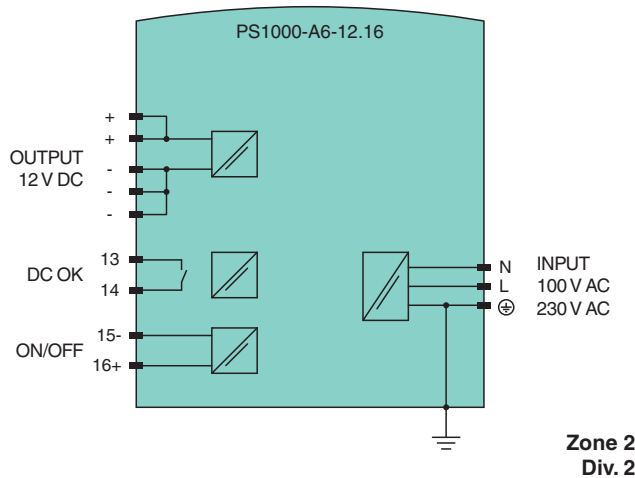

Technical Data

Electrical specifications	
Efficiency	92.8 % at 120 V AC 94.3 % at 230 V AC
Power dissipation	14.9 W at 120 V AC 11.6 W at 230 V AC
Input	
Voltage range	100 ... 240 V AC (-15 %/+10 %), 50 ... 60 Hz (±6 %) 110 ... 150 V DC (±20 %)
Current	1.74 A at 120 V AC 0.92 A at 230 V AC 1.9 A at 110 V DC for lower output currents see technical information
Inrush current	6 A peak at 120 V AC and ambient temperature 40 °C (104 °F) 9 A peak at 230 V AC and ambient temperature 40 °C (104 °F)

Release date: 2023-11-30 Date of issue: 2023-11-30 Filename: 70103519_eng.pdf

Technical Data

Capacity factor		0.99 at 120 V AC 0.96 at 230 V AC
Remote control		terminals 15-, 16+ remote control for ON/OFF
Output		
Rated voltage	U_r	12 V DC
Voltage range		12 ... 15 V DC factory setting: 12 V
Rated current	I_r	16 A
Current		19.2 ... 15.4 A at ambient temperature < 45 °C (113 °F) 16 ... 12.8 A at ambient temperature 60 °C (140 °F) 12 ... 9.6 A at ambient temperature 70 °C (158 °F) linear power derating see technical information
Power		192 W
Ripple		max. 50 mV _{pp}
Hold-up time		50 ms at 120 V AC 50 ms at 230 V AC
Overload behavior		continuous current : output voltage > 6.5 V DC intermittent current : output voltage < 6.5 V DC
Short-circuit current		typ. 55 A for up to 12 ms, load impedance < 30 mΩ
Voltage limitation		typ. 18.2 V DC max. 19 V DC
Fault indication output		
Connection		terminals 13, 14
Output type		relay contact DC OK - contact is closed if the output voltage is > 90 % of the adjusted output voltage
Contact loading		max. 60 V DC/0.3 A ; 30 V DC/1 A ; 30 V AC/0.5 A resistive load min. 1 mA at 5 V DC
Galvanic isolation		
Input/Output		SELV/PELV
Indicators/settings		
Display elements		LED green: status DC OK - LED lights up if the output voltage is > 90 % of the adjusted output voltage
Control elements		potentiometer
Configuration		setting of the output voltage via potentiometer
Directive conformity		
Electromagnetic compatibility		
Directive 2014/30/EU		IEC/EN 61000-6-1 , IEC/EN 61000-6-2 , IEC/EN 61000-6-3 , IEC/EN 61000-6-4 , IEC/EN 61000-3-2 , IEC/EN 61000-3-3
Low voltage		
Directive 2014/35/EU		EN 61010-1
RoHS		
Directive 2011/65/EU (RoHS)		IEC/EN 63000:2019
Conformity		
Degree of protection		EN 60529
Shock resistance		EN 60068-2-27
Vibration resistance		EN 60068-2-6
Ambient conditions		
Ambient temperature		-25 ... 70 °C (-13 ... 158 °F) , see technical information
Storage temperature		-40 ... 85 °C (-40 ... 185 °F)
Relative humidity		5 ... 95 % , noncondensing
Shock resistance		20 g , 11 ms or 30 g , 6 ms
Vibration resistance		2 ... 17.8 Hz : ± 1.6 mm , 17.8 ... 500 Hz : 2 g
Mechanical specifications		
Housing material		aluminum alloy , galvanized steel
Degree of protection		IP20
Connection		

Technical Data

Input/Output	screw terminals conductor cross section: max. 6 mm ² (AWG 20-10) cable diameter: max. 2.8 mm, wire end ferrules included stripped insulation length: 7 mm tightening torque: max. 1 Nm
Relay contact output	spring terminals conductor cross section: max. 1.5 mm ² (AWG 24-16) cable diameter: max. 1.6 mm, wire end ferrules included stripped insulation length: 7 mm
Remote control	spring terminals conductor cross section: max. 1.5 mm ² (AWG 24-16) cable diameter: max. 1.6 mm, wire end ferrules included stripped insulation length: 7 mm
Mass	approx. 600 g
Dimensions	39 x 124 x 117 mm (W x H x D) , without DIN mounting rail
Mounting	on 35 mm DIN mounting rail acc. to EN 60715:2001
Data for application in connection with hazardous areas	
ATEX approval	
ATEX certificate	EPS 15 ATEX 1101 X
ATEX marking	Ⓔ II 3G Ex ec nC II T4 Gc
Directive conformity	
Directive 2014/34/EU	EN 60079-0:2012+A11:2013 , EN 60079-7:2015+A1:2018 , EN 60079-15:2010
International approvals	
UL approval	E223176
IECEX approval	
IECEX certificate	IECEX EPS 20.0055X
IECEX marking	Ex ec nC IIC T4 Gc
Standards	IEC 60079-0:2017 , IEC 60079-7:2017 , IEC 60079-15:2017
General information	
Supplementary information	Observe the certificates, declarations of conformity, instruction manuals, and manuals where applicable. For information see www.pepperl-fuchs.com .

Assembly

Front view

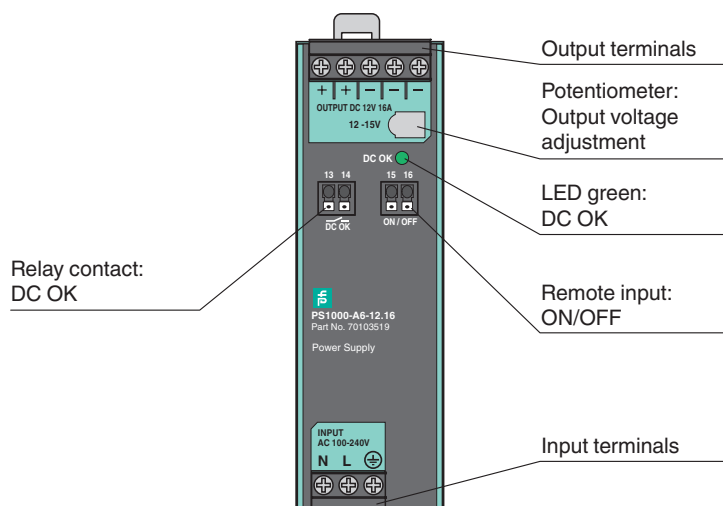

Installation Conditions

Mount the device on the DIN mounting rail so that the input terminals are located on the bottom of the device.

This device is designed for convection cooling and does not require an external ventilator. Do not obstruct airflow. Do not cover the ventilation grid by more than 15 %, e. g. cable ducts.

If you load the device with more than 50 % of the rated power permanently keep the following mounting distances:

- 40 mm above
- 20 mm below
- 5 mm on the left and right side

Increase this distance to 15 mm if the adjacent device is a heat source, e. g. another power supply.

Configuration

The remote control input allows to switch off the device output with a signal switch or transistor. To switch off the device, connect pins 15 and 16 with a plug-in jumper. Pin 15 is related to the (-) output voltage.

The open circuit voltage between pin 15 and pin 16 can be up to 18 V. The maximum current in the remote OFF mode can be up to 2.5 mA. The output shutdown threshold is typically 5 V. The threshold for switching the output on is typically 9 V.

If multiple devices are connected in parallel, pin 15 and pin 16 may also be connected in parallel. This allows all devices to be controlled by the same signal switch or transistor. Observe that the shutdown function is not a safety function.