



Optical reader - safePGV PGV100AQ-F200-B28-V1D

- SIL 3 (EN 61508)
- Category 4 PL e (EN ISO 13849)
- PROFINET interface
- PROFIsafe interface
- Safe, non-contact positioning on Data Matrix code tape
- Traverse distance up to 100 km
- Mechanically rugged: no wearing parts, long operating life, maintenance-free
- Output of code quality
- Pollution detection

Read head for incident light positioning system



Dimensions

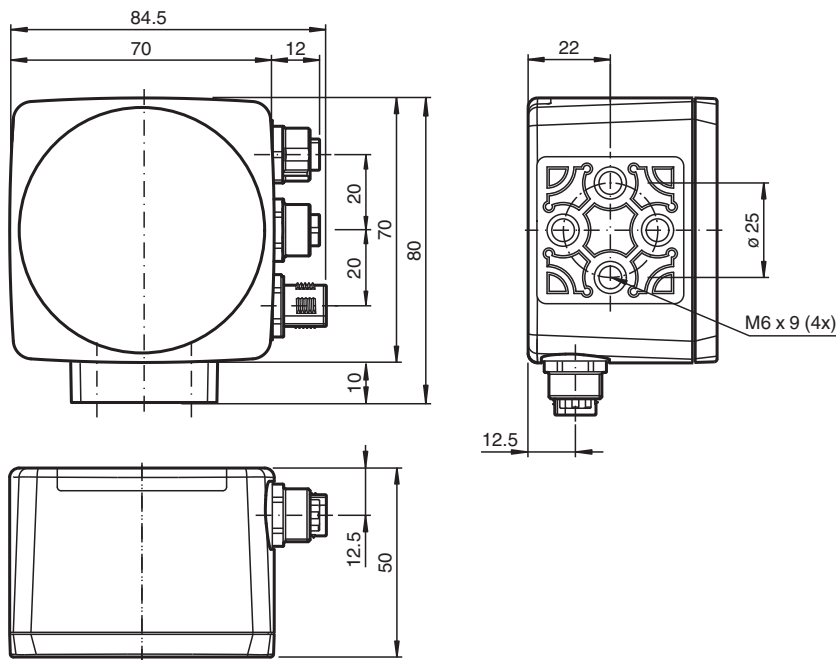

Technical Data

General specifications

Passage speed	v	≤ 8 m/s
Measuring length		max. 100000 m
Light type		Integrated LED lightning (red/blue)
Read distance		100 mm
Depth of focus		± 30 mm
Field of view		typ. 120 mm x 80 mm
Ambient light limit		30000 Lux
Accuracy		
Non safety-related X, Y		± 0.2 mm
Non safety-related angle α		± 0.5 °

Release date: 2025-05-16 Date of issue: 2025-05-21 Filename: 70105231_eng.pdf

Technical Data

Safety-related X	See the original instructions		
Nominal ratings			
Camera			
Type		CMOS , Global shutter	
Processor			
Clock pulse frequency		600 MHz	
Speed of computation		4800 MIPS	
Digital resolution		32 Bit	
Functional safety related parameters			
Safety Integrity Level (SIL)		SIL 3	
Performance level (PL)		PL e	
Category		Cat. 4	
Reaction time		165 ms	
MTTF		41 a	
MTTF _d		104.74 a	
Mission Time (T _M)		20 a	
PFH		1.09 E-8 typ.	
Indicators/operating means			
LED indication		7 LEDs (communication, status messages)	
Electrical specifications			
Operating voltage	U _B	20 ... 30 V DC , PELV	
No-load supply current	I ₀	max. 300 mA	
Power consumption	P ₀	6 W	
Interface			
Interface type		100 BASE-TX	
Protocol		PROFINET IO Real-Time (RT) Conformance class B	
Transfer rate		100 MBit/s	
Conformity			
Fieldbus standard		PROFIsafe in accordance with IEC 61784-3-3; profile 2.4	
Functional safety		EN ISO 13849-1:2023 EN 61508:2010 part 1-7	
Shock resistance		EN 60068-2-27:2009	
Vibration resistance		EN 60068-2-6:2008	
Emitted interference		EN 61000-6-4:2007+A1:2011	
Noise immunity		EN 61000-6-7:2015 EN 61326-3-1:2017	
Photobiological safety		Risk group 1 according to IEC 62471	
Approvals and certificates			
CE conformity		CE	
UL approval		cULus Listed, Class 2 Power Source, Type 1 enclosure	
CCC approval		CCC approval / marking not required for products rated ≤36 V	
TÜV approval		TÜV Rheinland 01/205/5669.02/25	
Ambient conditions			
Operating temperature		0 ... 45 °C (32 ... 113 °F) , -20 ... 45 °C (-4 ... 113 °F) (noncondensing; prevent icing on the lens!)	
Storage temperature		-40 ... 85 °C (-40 ... 185 °F)	
Relative humidity		90 % , noncondensing	
Altitude		max. 2000 m above MSL	
Mechanical specifications			
Connection type		8-pin, M12x1 connector, standard 4-pin, M12x1 socket, D-coded (LAN) 4-pin, M12x1 socket, D-coded (LAN)	
Degree of protection		IP67	
Material			
Housing		PC/ABS	
Mass		approx. 200 g	

Technical Data

Dimensions	
Height	70 mm
Width	70 mm
Depth	50 mm

Connection Assignment

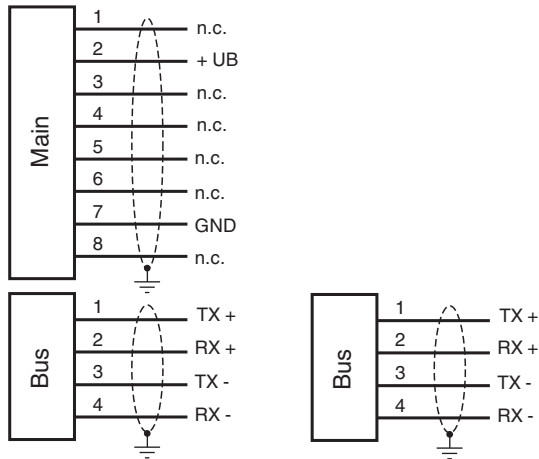

Connection Assignment

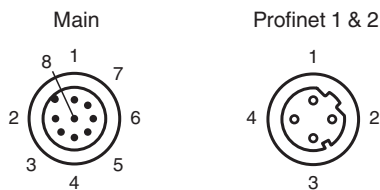

Characteristic Curve

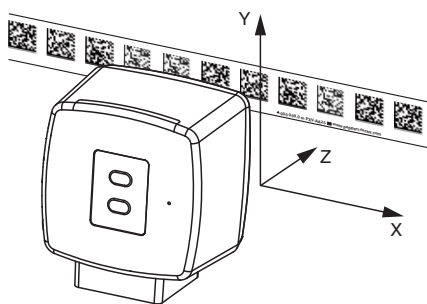

Release date: 2025-05-16 Date of issue: 2025-05-21 Filename: 70105231_eng.pdf

Characteristic Curve

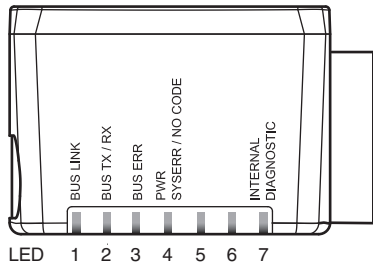
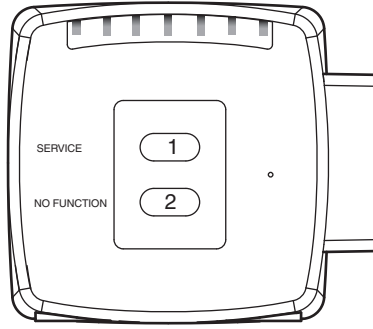

Release date: 2025-05-16 Date of issue: 2025-05-21 Filename: 70105231_eng.pdf

Additional Information

Function

The reader forms part of the positioning system in the Pepperl+Fuchs incident light process, working with stationary Data Matrix code tapes mounted on the ground. The device's features include a camera module with an internal illumination unit, which follows a stationary Data Matrix code tape affixed to the ground in parallel in order to reliably detect the position. The device can be used in all applications where automated guided vehicles (AGV) are to be positioned precisely at marked positions along a given spur.

The positioning system issues position values that achieve the reliability required by SIL 3 and PL e, provided that the device is properly integrated into the plant according to the specifications given in the original instructions.

Mounting and Commissioning

Mount the reader such that the optical surface of the device captures the optimal reading distance to the Data Matrix code tape (see "Technical Data"). The stability of the mounting and the manner in which the vehicle is guided ensure that the reader is not operated outside of its depth of focus range. The code tape must not leave the maximum reading window for the reader during this process.

Displays and Operating Elements

The reader is equipped with the following indicator LEDs for carrying out visual function checks and quick diagnostics:

LEDs

LED	Color	Label	Meaning
1	Green	BUS LINK	PROFINET connection activated
2	Yellow	BUS TX/RX	Data transfer
3	Red	BUS ERR	PROFINET communication error
4	Red/green	PWR SYSERR/NO CODE	Code detected/not detected, error
5	-	-	No function
6	-	-	No function
7	Red/green/yellow	INTERNAL DIAGNOSTIC	Internal diagnostics

The SERVICE button on the back of the device is used for internal service purposes.