

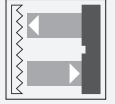

Retroreflective sensor

ML100-55-8096/103/115b/154 SET



- No controls
- Miniature design
- Clearly visible LEDs for Power ON, switching state and weak signal indication
- Very bright, highly visible light spot
- Full metal thread mounting
- Not sensitive to ambient light
- Sensor pre-assembled with metal bracket and clamping cylinder

Retroreflective sensor with polarization filter, plastic housing, 5 m detection range, red light, light on, DC version, PNP output, no controls, fixed cable with M12 plug



Function

The optical sensors of this series are suitable for both standard and demanding applications. The series features a miniature housing design, two M3 metal-threaded mounting holes and a highly visible LED status indicator. Each device is equipped with a sensitivity adjuster and a light-on/dark-on changeover switch for increased flexibility. A wide variety of versions are available in both infrared light and red light with PowerBeam for easy alignment. Special versions with BlueBeam are suitable for challenging applications like those in the solar and battery industries.

Dimensions

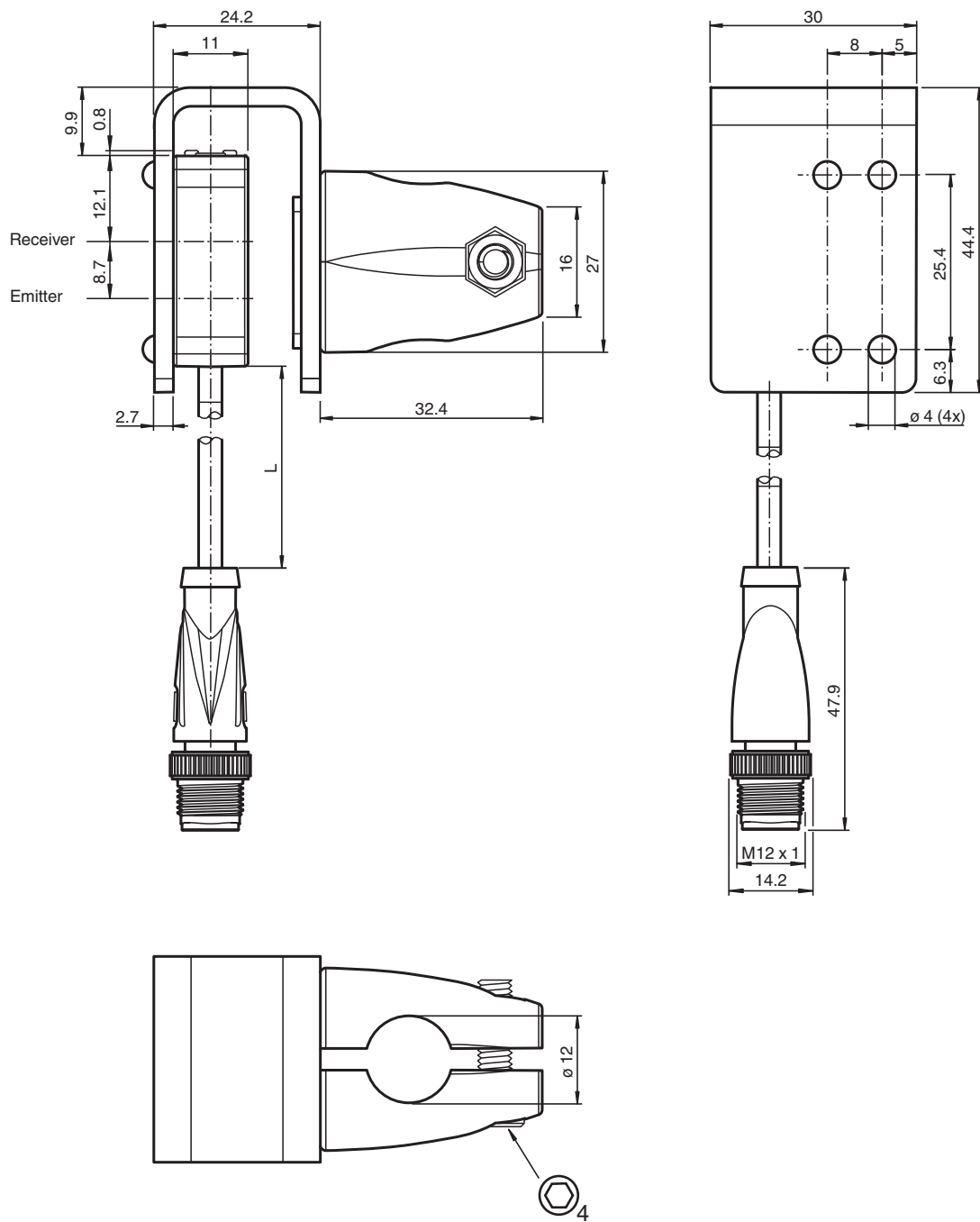

Release date: 2024-10-24 Date of issue: 2024-10-24 Filename: 70105786_eng.pdf

Technical Data

General specifications

Effective detection range	0 ... 5 m
Reflector distance	0.02 ... 5 m
Threshold detection range	7 m
Reference target	H50 reflector
Light source	LED
Light type	modulated visible red light
Polarization filter	yes

Technical Data

Diameter of the light spot		approx. 500 mm at a distance of 7 m
Opening angle		approx. 4 °
Optical face		frontal
Ambient light limit		EN 60947-5-2
Accessories provided		Stainless steel bracket with 2 x M3 x 12 phillips-slotted SEM pan head machine screws with flat washer and spring washer , Stainless steel A2 , passivated Clamping cylinder, zinc die-cast (factory pre-assembled)
Functional safety related parameters		
MTTF _d		860 a
Mission Time (T _M)		20 a
Diagnostic Coverage (DC)		0 %
Indicators/operating means		
Operation indicator		LED green: power on
Function indicator		LED yellow: lights up when receiving the light beam ; flashes when falling short of the operating reserve; OFF when light beam is interrupted
Electrical specifications		
Operating voltage	U _B	10 ... 30 V DC
Ripple		max. 10 %
No-load supply current	I ₀	< 20 mA
Output		
Switching type		light-on
Signal output		1 PNP output, short-circuit protected, reverse polarity protected, open collector
Switching voltage		max. 30 V DC
Switching current		max. 100 mA , resistive load
Voltage drop	U _d	≤ 1.5 V DC
Switching frequency	f	1000 Hz
Response time		0.5 ms
Conformity		
Product standard		EN 60947-5-2
Approvals and certificates		
UL approval		cULus Listed, Class 2 Power Source or listed Power Supply with a limited voltage output with (maybe integrated) fuse (max. 3.3 A according UL248), Type 1 enclosure
CCC approval		CCC approval / marking not required for products rated ≤36 V
Ambient conditions		
Ambient temperature		-30 ... 60 °C (-22 ... 140 °F)
Storage temperature		-40 ... 70 °C (-40 ... 158 °F)
Mechanical specifications		
Degree of protection		IP67
Connection		fixed cable with 4-pin, M12 x 1 connector
Material		
Housing		PC (Polycarbonate)
Optical face		PMMA
Cable		
Length	L	300 mm
Mass		approx. 20 g
Tightening torque, fastening screws		0.6 Nm
Dimensions		
Height		31 mm
Width		11 mm
Depth		20 mm

Connection

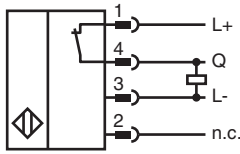

Connection Assignment



Wire colors in accordance with EN 60947-5-2

- 1 | BN (brown)
- 2 | WH (white)
- 3 | BU (blue)
- 4 | BK (black)

Indication

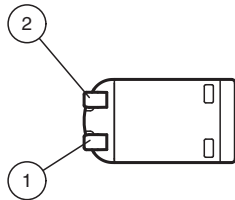

1	Signal display	yellow
2	Operating display	green

Mounting

Mounting

The sensors can be mounted directly via through-holes or by using a mounting bracket or a clamp component. Mounting brackets and clamp components are available as accessories.

Ensure that the surface is flat to avoid housing distortion during mounting and fixing.

Secure nut and bolt with spring washers to prevent misalignment of the sensor.

Adjusting the Sensor: Apply the operating voltage to the sensor. The power indicator lights green.

Mount a suitable reflector opposite the retroreflective sensor. Align the sensor (without object) roughly with the reflector. Then adjust the sensor to the reflector by tilting it horizontally and vertically until the yellow signal indicator is permanently lights up. If the alignment is inaccurate, the yellow signal indicator flashes.

Release date: 2024-10-24 Date of issue: 2024-10-24 Filename: 70105786_eng.pdf

Characteristic Curve

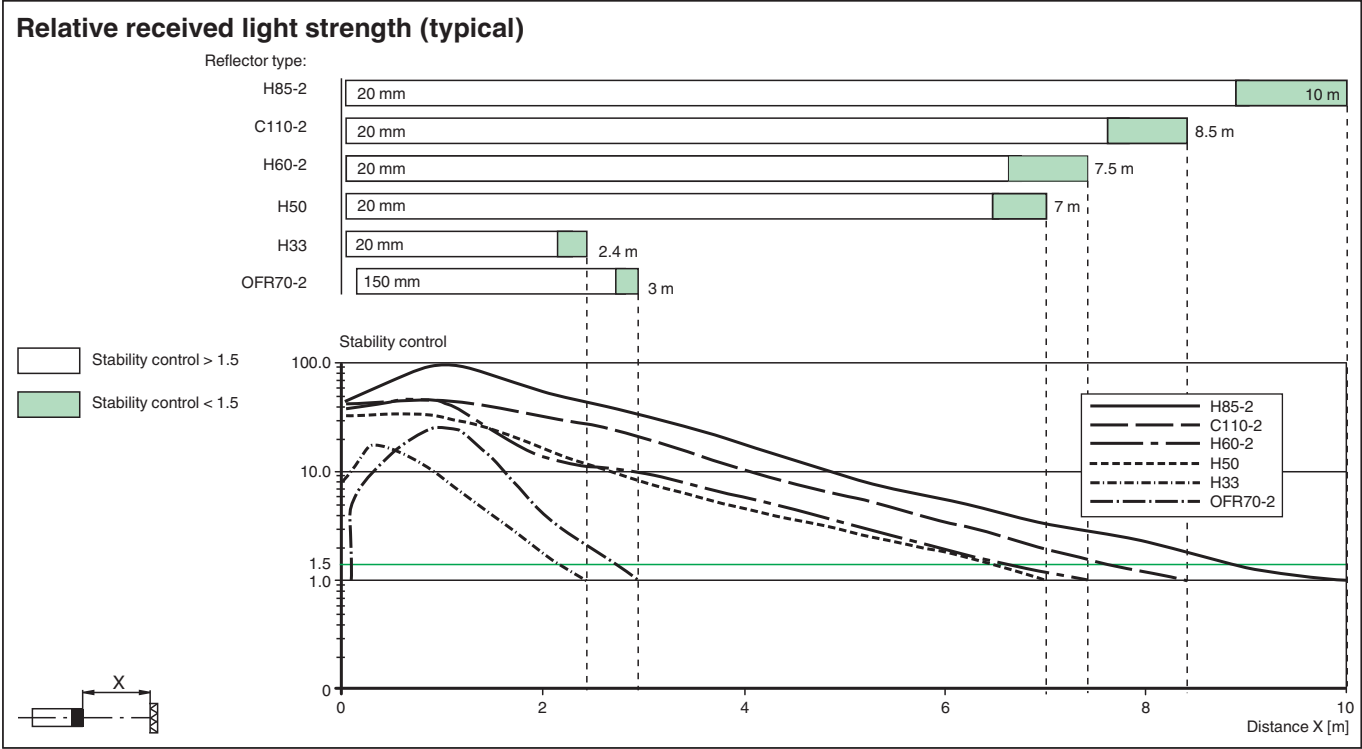
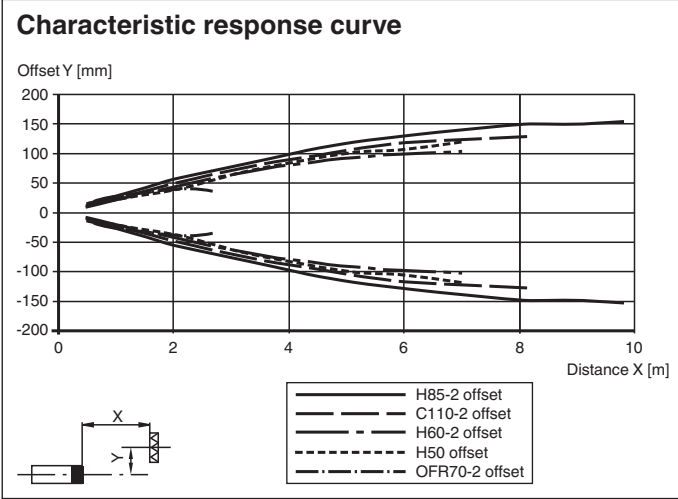



System Description

System Description
 The retro-reflective sensor contains both an emitter and a receiver in a single housing. A reflector reflects the light from emitter back to the receiver. If an object interrupts the light beam, the switching function is initiated.

Commissioning

Commissioning
Check Object Detection: Check as follows if the sensor detects objects as intended. Position the object in the beam path of the sensor. Once the object is detected, the yellow signal indicator goes out. As soon as the object leaves the beam path of the sensor, the yellow signal indicator permanently lights up again.

Kit component

	ML100-55/25/103/115b/1-54	Retroreflective sensor with polarization filter, plastic housing, 5 m detection range, red light, light on, DC version, PNP output, no controls, fixed cable with M12 plug
	MOUNT O030/024/044/V	Mounting aid for ML100 series, mounting bracket

Release date: 2024-10-24 Date of issue: 2024-10-24 Filename: 70105786_eng.pdf

Maintenance

Maintenance

Cleaning: If reception deteriorates, e. g. due to dirt, the yellow signal indicator of the receiver flashes. Clean the optical interfaces of the sensor (e. g. lenses) at regular intervals.

Servicing: Check the mounting screw connections and the electrical plug connections regularly.