

## Inductive sensor NCN3-F31K-N4-B13

- Direct mounting on standard actuators
- Fixed setting
- Cage clamp terminals
- Usable up to SIL 2 acc. to IEC 61508
- LEDs for switching state of sensor and solenoid valve
- Valve LEDs disconnectable
- ATEX & IECEX certifications

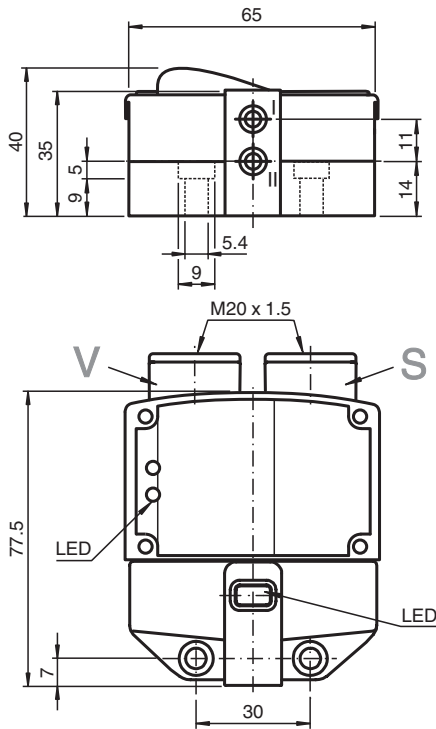

### Dimensions



### Technical Data

#### General specifications

Switching function		2 x normally closed (NC)
Output type		NAMUR
Rated operating distance	$s_n$	3 mm
Installation		flush mountable
Assured operating distance	$s_a$	0 ... 2.4 mm
Actual operating distance	$s_r$	2.7 ... 3.3 mm typ.
Actuating element		Stainless steel 1.4305 / AISI 303 8.5 mm x 8.5 mm x 0.5 mm
Reduction factor $r_{AI}$		0.5

Release date: 2025-07-03 Date of issue: 2025-07-03 Filename: 70110340\_eng.pdf

## Technical Data

Reduction factor $r_{Cu}$		0.4
Reduction factor $r_{304}$		1
Reduction factor $r_{Si37}$		1.3
Reduction factor $r_{Brass}$		0.6
Output type		2-wire
<b>Nominal ratings</b>		
Nominal voltage	$U_o$	8.2 V ( $R_i$ approx. 1 k $\Omega$ )
Switching frequency	f	0 ... 3 kHz
Hysteresis	H	typ. 5 %
Reverse polarity protection		reverse polarity protected
Short-circuit protection		yes
Suitable for 2:1 technology		yes , Reverse polarity protection diode not required
Current consumption		
Measuring plate not detected		$\geq 3$ mA
Measuring plate detected		$\leq 1$ mA
Time delay before availability	$t_v$	$\leq 1.1$ ms
Switching state indicator		LED, yellow
Valve status indicator		LED, yellow
<b>Functional safety related parameters</b>		
Safety Integrity Level (SIL)		SIL 2
MTTF <sub>d</sub>		1470 a
Mission Time ( $T_M$ )		20 a
Diagnostic Coverage (DC)		0 %
<b>Valve circuit</b>		
Voltage		max. 32 V DC
Current		max. 240 mA
Short-circuit protection		no
Reverse polarity protection		yes, with reversed output LED is out of function, therefore more power for solenoid valve
<b>Compliance with standards and directives</b>		
Standard conformity		
NAMUR		EN 60947-5-6:2000 IEC 60947-5-6:1999
Electromagnetic compatibility		NE 21:2007
Standards		EN IEC 60947-5-2
<b>Approvals and certificates</b>		
IECEX approval		
Equipment protection level Ga		IECEX TUN 17.0021X
Equipment protection level Gb		IECEX TUN 17.0021X
Equipment protection level Mb		IECEX TUN 17.0021X
ATEX approval		
Equipment protection level Ga		TÜV 99 ATEX 1479 X
Equipment protection level Gb		TÜV 99 ATEX 1479 X
Equipment protection level Gc (ic)		PF 13 CERT 2895 X
UL approval		
		cULus Listed Load Type: General Purpose Circuitry: Class 2 Power Source Enclosure Type Rating: Type 1 Supply/Switching Voltage: 8.2 V DC
Ordinary Location		E87056
Hazardous Location		E501628
Control drawing		116-0456
CCC approval		
Hazardous Location		2020322315002262
NEPSI approval		
NEPSI certificate		GYJ19.1410X

Release date: 2025-07-03 Date of issue: 2025-07-03 Filename: 70110340\_eng.pdf

## Technical Data

Ambient conditions	
Ambient temperature	-25 ... 100 °C (-13 ... 212 °F)
Storage temperature	-40 ... 100 °C (-40 ... 212 °F)
Mechanical specifications	
Connection (system side)	Cage tension spring terminals Stripped length 7 mm M20 x 1.5 cable gland usable thread length 11.5 mm screw-in depth max. 11.5 mm
Core cross section (system side)	rigid: 0.14 ... 2.5 mm <sup>2</sup> flexible: 0.14 ... 1.5 mm <sup>2</sup> flexible with core-end sleeve: 0.25 ... 1.5 mm <sup>2</sup>
Connection (valve side)	like connection (system side)
Core cross section (valve side)	like core cross section (system side)
Housing material	PBT
Sensing face	PBT
Degree of protection	IP67
Tightening torque, fastening screws	≤ 5 Nm
Tightening torque, housing screws	1 Nm
Tightening torque, cable gland	M20 x 1.5 ; max. 7 Nm
Dimensions	
Height	35.5 mm
Width	65 mm
Length	77.5 mm
Note	LED switch-off
General information	
Use in the hazardous area	see instruction manuals

## Connection Assignment

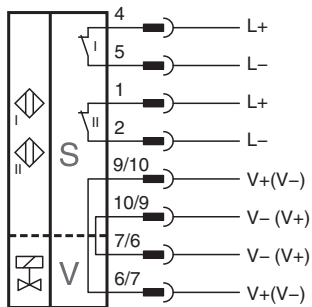

## Additional Information

### Interruption of LED:

In the case of a polarity reversal of the valve circuit connection/s, the valve status display does not function, i.e. such that low power valves can (also) be connected.