



## Mounting aid

### MH-EXG-12

- Clamp for threaded pipe
- Suitable for all M12 sensors, including reduction factor 1
- Simple and quick exchange without readjustment
- 2 panel nuts included
- Free of paint wetting interfering substances
- Significantly reduced influence on the switching distance

Quick mounting bracket with dead stop

## Dimensions

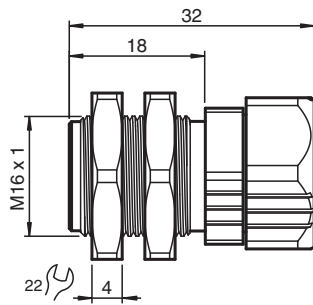

## Technical Data

<b>Ambient conditions</b>		
Ambient temperature		-40 ... 90 °C (-40 ... 194 °F)
<b>Mechanical specifications</b>		
Length	L	32 mm thread length of sensor min. 32 mm
Diameter		sensor min. 11.8 mm sensor max. 12 mm
Material		brass, nickel-plated free of paint wetting interfering substances
Screwed connection		SW = 22 mm
Dimensions		M16 x 1 external thread
Tightening torque		20 Nm nuts 5 4 Nm nut 1
<b>General information</b>		
Note		Attention: Sensor shape dependent, it will be fixed up to 0.7 mm in back-flush position.

Release date: 2024-03-26 Date of issue: 2024-03-26 Filename: 70112557\_eng.pdf

## Mounting

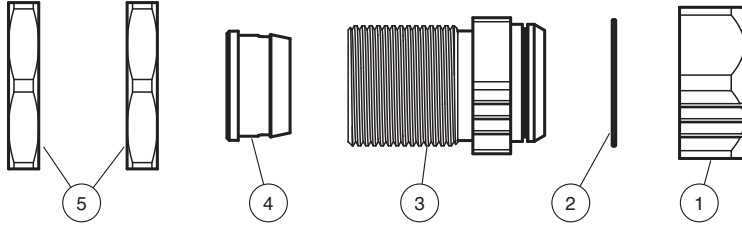

## Mounting

1. Screw one hexagonal nut (5) onto the thread of sleeve (3).
  2. Push sleeve (3) from the panel back side through an appropriate drill hole in the application.
  3. Screw the second nut (5) from the panel front side onto the thread of sleeve (3).
  4. Use both nuts (5) to adjust the horizontal position of the sensor.
  5. Tighten the nuts (5) with the appropriate torque.
  6. The fixation nut (1) turns on the retaining ring (2). Turn (1) until the three grooves on (1) and (3) are in line.
  7. Insert the sensor from right-hand side through the inner hole of sleeve (3) until it touches the position stop (4).
  8. Turn fixation nut (1) clockwise to fix the sensor. The use of tools is not necessary.
- The sensor is fixed in position.