

# Ultrasonic sensor

## UB500-F42-E6-V15-Y70123089



- 2 independent switch outputs
- Extremely small unusable area
- Synchronization options
- Customer-specific configuration

Single head system



### Dimensions

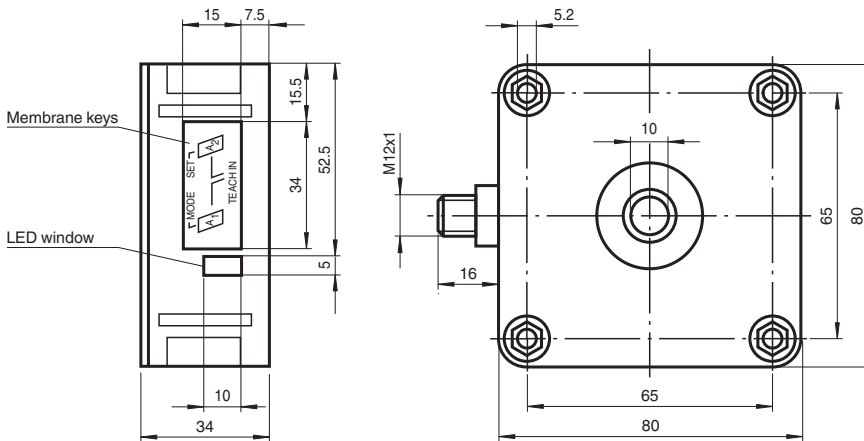

### Technical Data

#### General specifications

Sensing range	30 ... 203 mm
Adjustment range	fixed setting
Dead band	0 ... 30 mm
Standard target plate	100 mm x 100 mm
Transducer frequency	approx. 390 kHz
Response delay	approx. 50 ms

#### Indicators/operating means

LED green	solid green: Power on
LED yellow 1	solid: switching state switch output 1 flashing: program function
LED yellow 2	solid: switching state switch output 2 flashing: program function
LED red	normal operation: "fault" program function: no object detected

#### Electrical specifications

Operating voltage	$U_B$	10 ... 30 V DC , ripple 10 % <sub>SS</sub>
No-load supply current	$I_0$	≤ 50 mA

#### Input/Output

Release date: 2025-06-03 Date of issue: 2025-06-03 Filename: 70123089\_eng.pdf

## Technical Data

Synchronization		bi-directional 0 level: $-U_B \dots +1 \text{ V}$ 1 level: $+4 \text{ V} \dots +U_B$ input impedance: $> 12 \text{ KOhm}$ synchronization pulse: $\geq 100 \mu\text{s}$ , synchronization interpulse period: $\geq 2 \text{ ms}$
Synchronization frequency		
Common mode operation		max. 95 Hz
Multiplex operation		$\leq 95/n \text{ Hz}$ , n = number of sensors
<b>Output</b>		
Output type		2 switch outputs PNP, NC
Rated operating current	$I_e$	200 mA, short-circuit/overload protected
Default setting		Switch point A1: 203 mm, Switch point A2: 203 mm, Normally closed (NC), wide sound lobe
Voltage drop	$U_d$	$\leq 2.5 \text{ V}$
Repeat accuracy		$\leq 0.5 \%$ of switching point
Switching frequency	f	$\leq 8 \text{ Hz}$
Range hysteresis	H	1 % of the set operating distance
Temperature influence		$\pm 1 \%$ of full-scale value
<b>Compliance with standards and directives</b>		
Standard conformity		
Standards		EN IEC 60947-5-2:2020 IEC 60947-5-2:2019
<b>Approvals and certificates</b>		
UL approval		cULus Listed, Class 2 Power Source
CCC approval		CCC approval / marking not required for products rated $\leq 36 \text{ V}$
<b>Ambient conditions</b>		
Ambient temperature		$-25 \dots 70 \text{ }^\circ\text{C}$ ( $-13 \dots 158 \text{ }^\circ\text{F}$ )
Storage temperature		$-40 \dots 85 \text{ }^\circ\text{C}$ ( $-40 \dots 185 \text{ }^\circ\text{F}$ )
<b>Mechanical specifications</b>		
Connection type		Connector plug M12 x 1, 5-pin
Degree of protection		IP54
Material		
Housing		ABS
Transducer		epoxy resin/hollow glass sphere mixture; foam polyurethane, cover PBT
Mass		140 g
Dimensions		
Height		80 mm
Width		80 mm
Length		34 mm
<b>Factory settings</b>		
Beam width		wide

## Connection Assignment

### Standard symbol/Connections: (version E6, prnp)

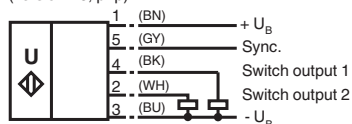

Core colours in accordance with EN 60947-5-2.

**Connection Assignment**

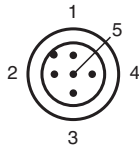

Wire colors in accordance with EN 60947-5-2

1	BN	(brown)
2	WH	(white)
3	BU	(blue)
4	BK	(black)
5	GY	(gray)

**Characteristic Curve**

**Characteristic response curve**

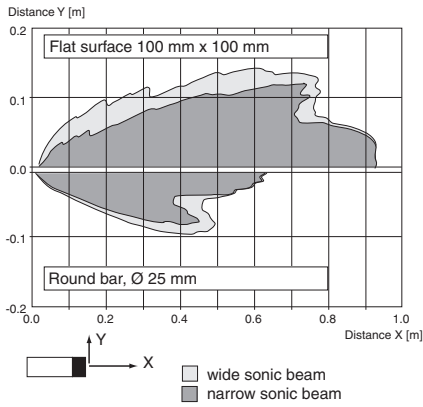

Release date: 2025-06-03 Date of issue: 2025-06-03 Filename: 70123089\_eng.pdf

## Operation

### Synchronisation

The sensor is equipped with a synchronisation connection to suppress mutual interaction. If it is not turned on, the sensor works at an internally generated cycle rate. Synchronisation of more than one sensor is possible in a number of different ways.

External synchronisation:

The sensor can be synchronised by the application of a square wave voltage externally. A synchronisation pulse on the synchronisation input results in the execution of a measurement cycle. The pulse width must be greater than 100 µs. The measurement cycle must be started with the falling signal edge. A Low level > 1 s or an open synchronisation input results in normal operation of the sensor. A High level on the synchronisation input deactivates the sensor.

Two different operating modes are possible

- Multiple sensors can be controlled by the same synchronisation signal. The sensors work on synonymous cycle.
- Synchronisation pulses are sent cyclically to only one sensor each time. The sensors work in Multiplex mode.

Self synchronisation:

The synchronisation connections of up to 5 sensors with option for self-synchronisation are connected with each other. These sensors work after turning on the operating voltage in Multiplex mode. The On delay increases depending on the number of sensors to be synchronised. Synchronisation is possible during Teach-in and vice-versa. Sensors must be operated unsynchronised to perform Teach-in of switching points.

### Note:

If the option for synchronisation is not used, the synchronisation input can be connected with ground (0 V) or the sensor can be operated with a V1 connection cable (4-pin).