

Diffuse mode sensor

OBD300-12GM40-E5-0,3M-V31



- Robust M12 threaded housing
- Less space required
- Light-on/dark-on, programmable
- Degree of protection IP67

Diffuse mode sensor, M12 threaded housing design, metal housing, front optical face, 300 mm detection range, red light, light/dark on, 1 PNP output, fixed cable



Dimensions

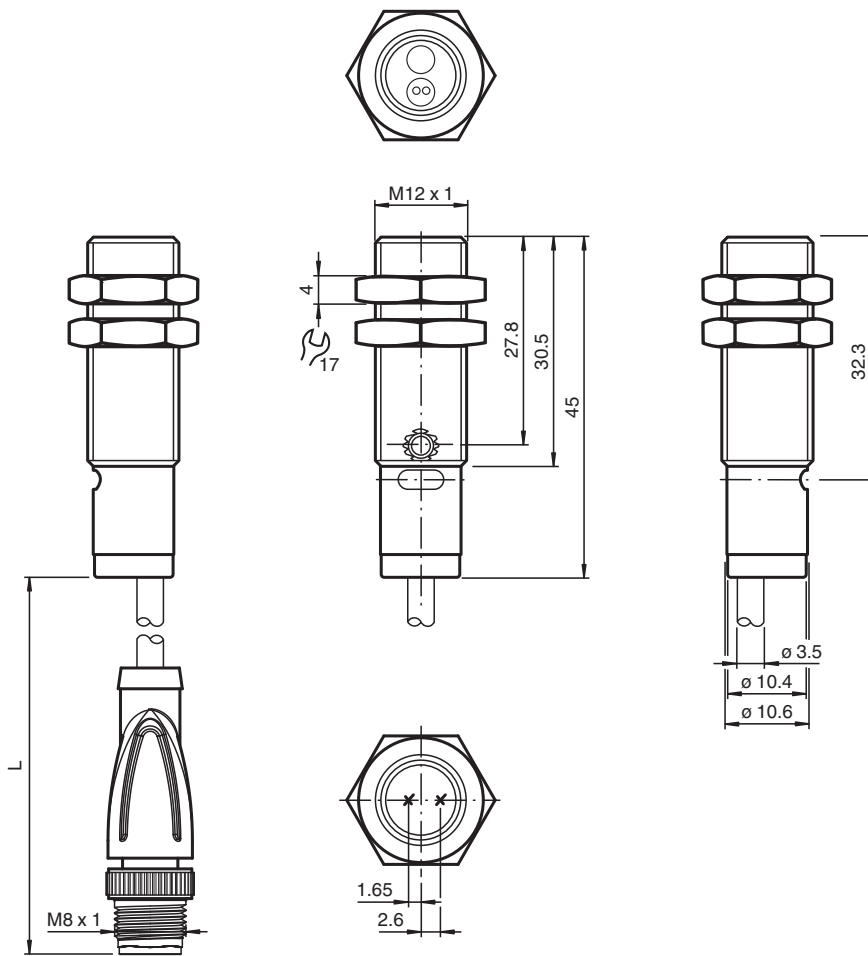

Technical Data

General specifications

Detection range 0 ... 300 mm

Release date: 2023-04-05 Date of issue: 2023-04-05 Filename: 70124178_eng.pdf

Technical Data

Adjustment range		20 ... 300 mm
Reference target		standard white 100 mm x 100 mm
Light source		LED
Light type		red , 640 nm
Angle deviation		+/- 2 °
Diameter of the light spot		approx. 20 mm at a distance of 300 mm
Opening angle		approx. 4 °
Optical face		frontal
Ambient light limit		EN 60947-5-2 10000 Lux
Functional safety related parameters		
MTTF _d		800 a
Mission Time (T _M)		20 a
Diagnostic Coverage (DC)		0 %
Indicators/operating means		
Operation indicator		LED green: Power on
Function indicator		LED yellow ON: lights when object is detected
Control elements		Sensing range adjuster
Electrical specifications		
Operating voltage	U _B	10 ... 30 V DC , class 2
Ripple		10 %
No-load supply current	I ₀	≤ 15 mA
Input		
Control input		light on +UB dark on: 0 V
Output		
Switching type		light/dark on electrically switchable
Signal output		1 PNP output, short-circuit protected, reverse polarity protected, open collector
Switching voltage		max. 30 V DC
Switching current		max. 100 mA , resistive load
Voltage drop	U _d	≤ 2 V
Switching frequency	f	≤ 1000 Hz
Response time		0.5 ms
Conformity		
Product standard		EN 60947-5-2
Compliance with standards and directives		
Standard conformity		
Standards		UL 508
Approvals and certificates		
UL approval		cULus Listed, Class 2 Power Source, Type 1 enclosure
CCC approval		CCC approval / marking not required for products rated ≤36 V
Approvals		CE, cULus Listed 57M3 (Only in association with UL Class 2 power supply; Type 1 enclosure)
Ambient conditions		
Ambient temperature		-30 ... 60 °C (-22 ... 140 °F)
Storage temperature		-40 ... 70 °C (-40 ... 158 °F)
Mechanical specifications		
Degree of protection		IP67
Connection		fixed cable with 4-pin M8 x 1 connector
Material		
Housing		brass, nickel-plated
Optical face		PMMA
Cable		
Length	L	300 mm
Mass		approx. 45 g

Release date: 2023-04-05 Date of issue: 2023-04-05 Filename: 70124178_eng.pdf

Connection

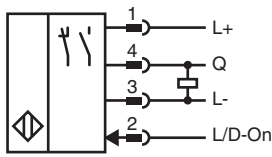

Connection Assignment



Wire colors in accordance with EN 60947-5-2

- 1 | BN (brown)
- 2 | WH (white)
- 3 | BU (blue)
- 4 | BK (black)

Assembly

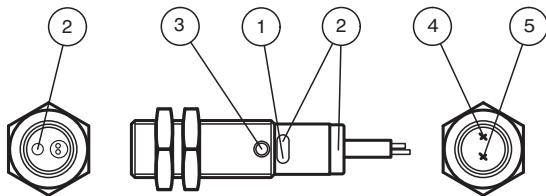

1	Operating display	green
2	Signal display	yellow
3	Potentiometer	
4	Emitter	
5	Receiver	

Characteristic Curve

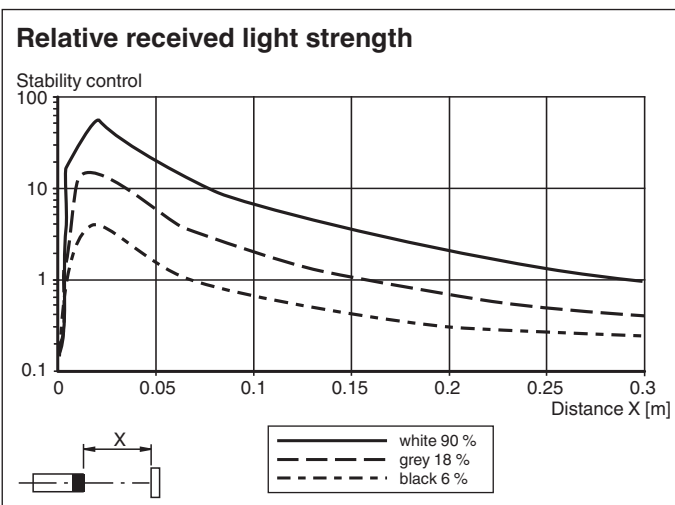

Release date: 2023-04-05 Date of issue: 2023-04-05 Filename: 70124178_eng.pdf

Characteristic Curve

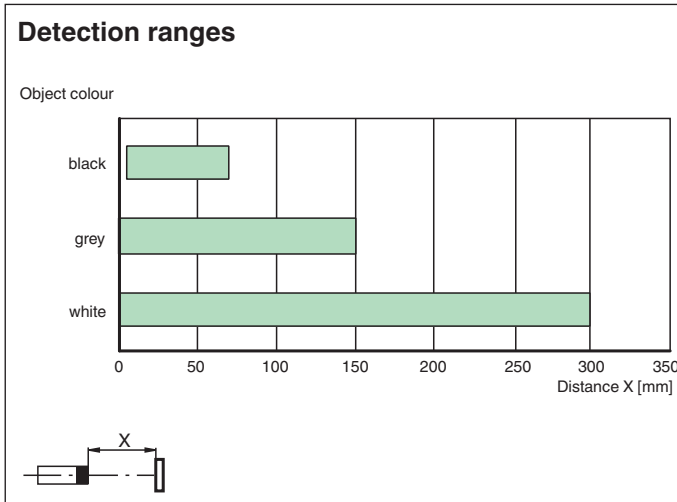

Additional Information

System Description

A retroreflective sensor contains both an emitter and a receiver in a single housing. The light of the emitter is reflected by the detected object, returned to, and evaluated by the receiver. The sensing range depends on the object color. For dark or very small objects, the sensing range is reduced.

Mounting

The sensor has an M12 x 1 threaded design and a nut with AF = 17 mm to be tightened with a maximum torque of 1.5 Nm.

- Direct sensor mounting: Screw into a single bore hole of Ø 12 mm.
- Sensor mounting with bracket: Possible. Not included in the delivery.

When mounting the sensor, ensure the visibility of the control elements and LEDs.

Adjusting the sensitivity

Apply operating voltage to the sensor. The power indicator lights green.

Application type I: During normal operation, an object is present in the detection field of the sensor. Adjust the sensitivity of the sensor as follows. Turn the sensitivity adjuster counter-clockwise until it reaches minimum. Next determine the positions A and B:

- Position A: Position the object in the scanning range of the sensor. Turn the sensitivity adjuster clockwise until the yellow indicator lights up. => The sensitivity adjuster is now set to position A. Make a note of this setting.
- Position B: Remove the object from the scanning range of the sensor. Turn the sensitivity adjuster counter-clockwise until the yellow indicator lights up again. => The sensitivity adjuster is now set to position B. Make a note of this setting.

Application type II: During normal operation, no object (e.g. parked pallet etc.) is present in the detection range of the sensor. It is not necessary to determine the position with an object present in order to adjust the sensitivity of the sensor.

In case no object is present, the yellow indicator will not even light up when the adjuster is set to the absolute maximum.

Application type III: During normal operation, no object (e.g. parked pallet etc.) is present in the detection range of the sensor. It cannot be guaranteed that no object will ever be present in the detection range of the sensor.

Determine the likely position of the object to set the sensor's sensitivity, compare application type I. Therefore, place an object at the most likely position and, after you have determined A and B, remove the object again. For optimum adjustment turn the sensitivity adjuster in the middle between the positions A and B.

Maintenance

Cleaning: Clean the light emitter of the sensor at regular intervals.

Servicing: Check the mounting screw connections and the electrical plug connections regularly.

Accessories

	BF 12	Mounting flange, 12 mm
	BF 12-F	Plastic mounting adapter, 12 mm
	BF 5-30	Universal mounting bracket for cylindrical sensors with a diameter of 5 ... 30 mm
	V31-GM-2M-PUR	Female cordset single-ended M8 straight A-coded, 4-pin, PUR cable grey
	V31-WM-2M-PUR	Female cordset single-ended M8 angled A-coded, 4-pin, PUR cable grey

Release date: 2023-04-05 Date of issue: 2023-04-05 Filename: 70124178_eng.pdf