

Termination Board

HiCTB16-TRX-RAC-PL-AI16

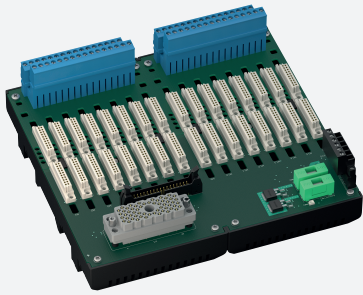

- System board for Schneider Electric, Tricon CX series by Triconex
- TAN48 approval
- For 32-channel (16+16) AI cards 3722X and 3723X
- For 16 modules
- Recommended modules: HiC2025(A) (AI), HiC2025ES (AI), HiC2081 (TI)
- 24 V DC supply
- Hazardous area: pluggable screw terminals, blue
- Non-hazardous area: ELCO socket, 56-pin



Function

The function of the termination board and the system connector pin assignment is exactly fitted to the requirements of the Triconex Tricon CX system.
 The signal is output to the safety instrumented system via the system connector.
 Information about missing supply voltage of the isolated barriers is available for the system at the volt-free transistor output.
 Wiring faults from the field side will be reported via the volt-free transistor output, if this function is supported by the isolators.
 The termination board has a robust glass fiber reinforced plastic housing.
 The termination board is mounted in the switch cabinet on a 35 mm DIN mounting rail according to EN 60175.

Application

- Triconex card Tricon CX:
- Termination board 1 and cable 1: channel 1 ... 16
 - Termination board 2 and cable 2: channel 17 ... 32

Connection

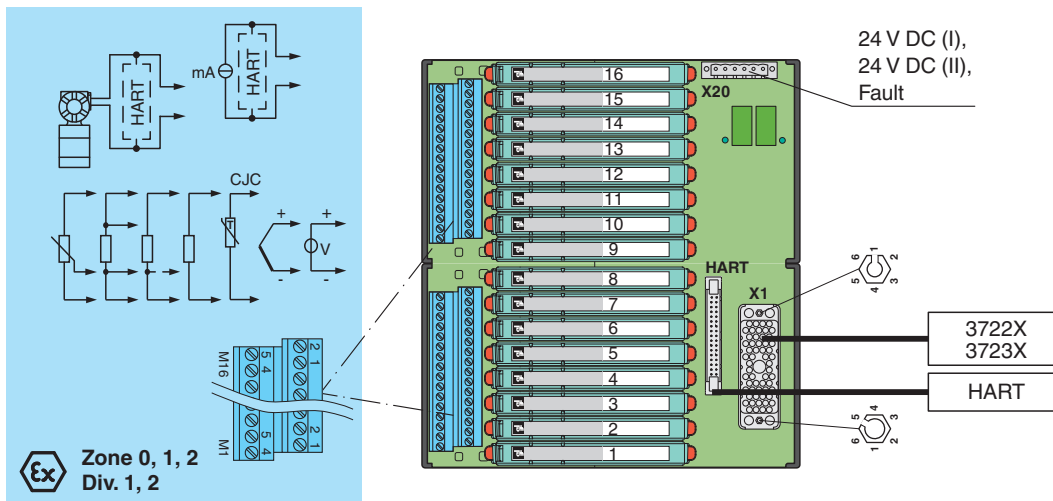

Technical Data

Supply	
Connection	X20: terminals 3, 5(+); 4, 6(-)
Nominal voltage	24 V DC , in consideration of rated voltage of used isolators
Voltage drop	0.9 V , voltage drop across the series diode on the termination board must be considered
Ripple	≤ 10 %

Release date: 2023-10-23 Date of issue: 2023-10-23 Filename: 70127424_eng.pdf

Technical Data

Fusing	4 A , in each case for 16 modules	
Power dissipation	≤ 500 mW , without modules	
Reverse polarity protection	yes	
Redundancy		
Supply	Redundancy available. The supply for the isolators is decoupled, monitored and fused.	
Fault indication output		
Connection	X20: terminals 1(+), 2(-)	
Output type	volt-free transistor output , not short-circuit protected , not overload protected	
Rated voltage	U_r	30 V DC
Rated current	I_r	100 mA
Signal level	no fault: (external voltage) - 1 V max. for 100 mA ($T_{amb} = 25\text{ °C}$ (77 °F)) power supply fault/module fault: blocked output (off-state current ≤ 10 μA)	
Indicators/settings		
Display elements	LED PWR1 (termination board power supply), green LED LED PWR2 (termination board power supply), green LED	
Directive conformity		
Electromagnetic compatibility		
Directive 2014/30/EU	EN 61326-1:2013 (industrial locations)	
Conformity		
Electromagnetic compatibility	NE 21:2017 For further information see system description.	
Degree of protection	IEC 60529:2001	
Ambient conditions		
Ambient temperature	-20 ... 60 °C (-4 ... 140 °F)	
Storage temperature	-40 ... 85 °C (-40 ... 185 °F)	
Mechanical specifications		
Degree of protection	IP20	
Connection		
Field side	explosion hazardous area: pluggable screw terminals , blue	
Control side	non-explosion hazardous area: ELCO socket, 56-pin	
Supply	pluggable screw terminals , black	
Fault output	pluggable screw terminals , black	
Core cross section	screw terminals 0.25 ... 2.5 mm ² (24 ... 12 AWG)	
Material	housing: polycarbonate, 10 % glass fiber reinforced	
Mass	approx. 775 g	
Dimensions	216 x 200 x 163 mm (8.5 x 7.9 x 6.42 inch) (W x H x D) , depth including module assembly	
Mounting	on 35 mm DIN mounting rail acc. to EN 60715:2001	
Data for application in connection with hazardous areas		
EU-type examination certificate	CESI 06 ATEX 022	
Marking	⊕ II (1)G [Ex ia Ga] IIC ⊕ II (1)D [Ex ia Da] IIIC ⊕ I (M1) [Ex ia Ma] I	
Non-hazardous area		
Maximum safe voltage	250 V (Attention! U_m is no rated voltage.)	
Galvanic isolation		
Field circuit/control circuit	safe electrical isolation acc. to IEC/EN 60079-11, voltage peak value 375 V	
Directive conformity		
Directive 2014/34/EU	EN IEC 60079-0:2018+AC:2020 , EN 60079-11:2012 , EN 50303:2000	
International approvals		
UL approval	E106378	
Control drawing	116-0327	
IECEX approval		
IECEX certificate	IECEX CES 06.0003	

Release date: 2023-10-23 Date of issue: 2023-10-23 Filename: 70127424_eng.pdf

Technical Data

IECEEx marking









[Ex ia Ga] IIC
 [Ex ia Da] IIC
 [Ex ia Ma] I

General information

Supplementary information

Observe the certificates, declarations of conformity, instruction manuals, and manuals where applicable. For information see www.pepperl-fuchs.com.

Accessories

	HiATB01-HART-2X16	HART Communication Board
	HiDMux2700	HART Multiplexer Master
	H-CJC-Pt100	Resistance thermometer for cold junction compensation for H-System termination boards
	HiACA-UNI-FLK34-FLK34-0M5	HART Connection Cable, length: 0,5 m
	HiACA-UNI-FLK34-FLK34-1M0	HART Connection Cable, length: 1 m
	HiACA-UNI-FLK34-FLK34-2M0	HART Connection Cable, length: 2 m
	HiACA-UNI-FLK34-FLK34-3M0	HART Connection Cable, length: 3 m
	HiACA-UNI-FLK34-FLK34-6M0	HART Connection Cable, length: 6 m
	HiALC-HiCTB-SET-108	Label carrier for HiC termination boards

Application

Typical circuit

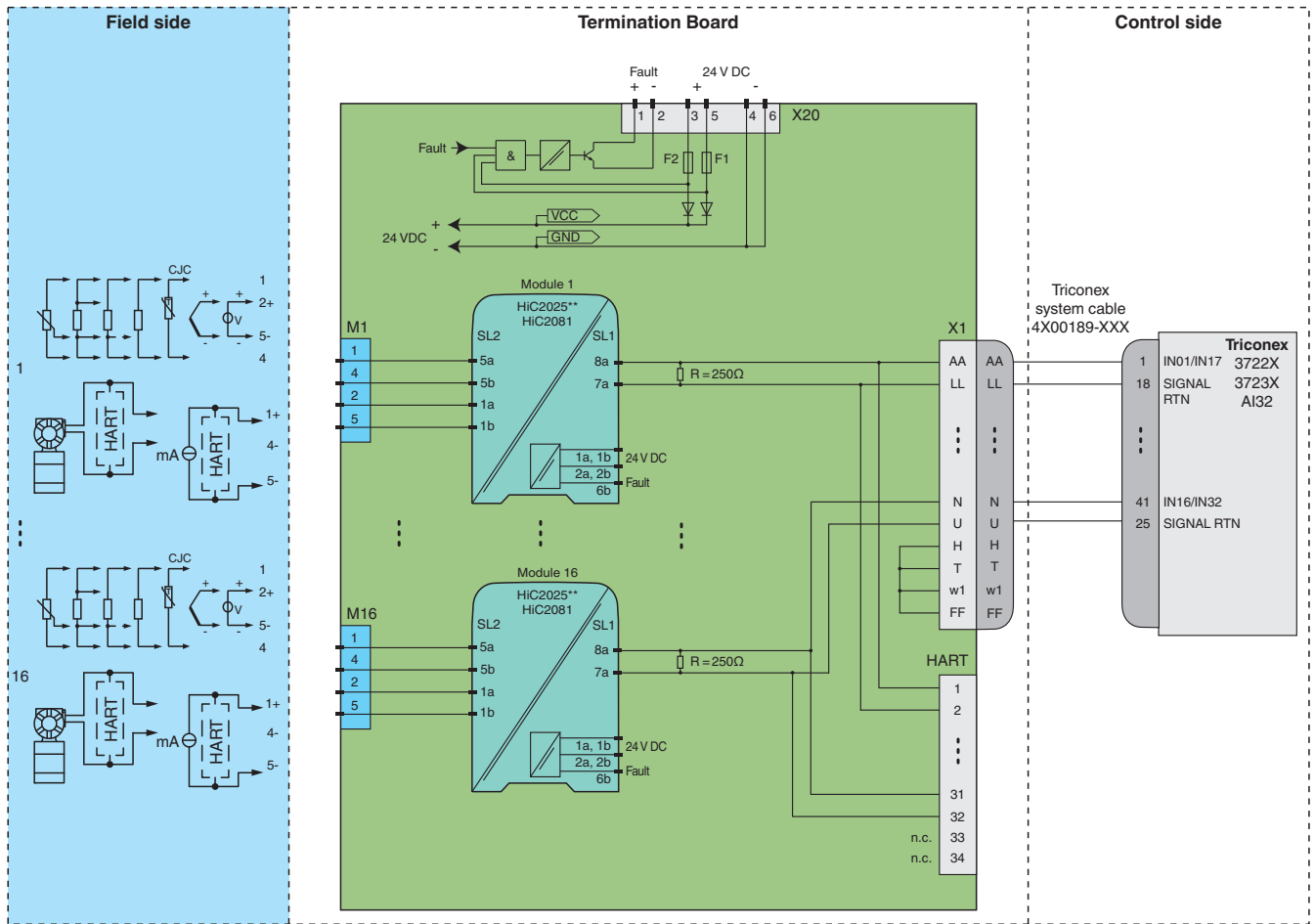

Module switch settings

Type (AI)	DIP switch	Position
HiC2025, HiC2025A, HiC2025ES, HiC2025Y1 (source 4 mA ... 20 mA)	S1	OFF
	S2	OFF
	S3	ON
	S4	OFF

Type (AI)	DIP switch	Position
HiC2081 (source)	S	I



For exact pin assignment for field side and control side see the documentation of the isolated barrier.



The pin-out configuration has to be observed. For information see corresponding pin-out table on www.pepperl-fuchs.com.