

Relay Module

KFD0-RSH-1.4S.PS2

- 1-channel signal conditioner
- 24 V DC supply (loop powered)
- Logic input 20 V DC ... 26.5 V DC, non-polarized
- Fail-safe relay contact output for de-energized and energized to safe function
- Test pulse immunity
- Up to SIL 3 acc. to IEC/EN 61508

CE SIL3

Function

This signal conditioner is a relay module that is suitable for safely switching applications of a load circuit. The device isolates load circuits up to 230 V and the 24 V control interface. The energized to safe (ETS) function is permitted for SIL3 applications with output I. The de-energized to safe (DTS) function is permitted for SIL3 applications with output II. Additionally a dual pole switching (DPS) is possible by combination of output I and II. The relays are of diverse design, but have a common effect on the individual switch output. For checking of these relays, terminals 10, 11 and 12 can be used. The test mode will be indicated by LEDs according to NAMUR NE44. The outputs are galvanically isolated from the input. Output II is protected against contact welding by a fuse depending on the used terminal.

Application

This device is compatible to the controls:

- Yokogawa ProSafe DO cards SDV531, SDV541
- Honeywell DO card SDO-0824

Compatibility check to other ESD/DCS systems on request.

Connection

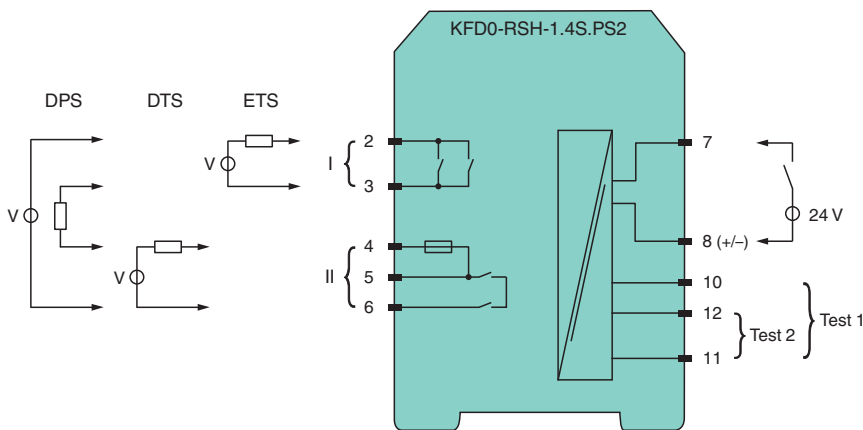

Technical Data

General specifications	
Signal type	Digital Output
Functional safety related parameters	
Safety Integrity Level (SIL)	SIL 3
Supply	
Rated voltage	U _r 0-signal: -3 ... 3 V DC , loop powered 1-signal: 20 ... 26.5 V DC , loop powered

Release date: 2024-09-04 Date of issue: 2024-09-04 Filename: 70132178_eng.pdf

Technical Data

Power dissipation		< 1.5 W
Power consumption		< 1.5 W
Input		
Connection side		control side
Connection		Input terminals 7, 8 ; test input terminals 10, 11, 12
Pulse/Pause ratio		min. 20 ms / min. 20 ms
Test input		see functional safety manual
Signal level		0-signal: -3 ... 3 V DC 1-signal: 20 ... 26.5 V
Rated current	I_r	45 ... 50 mA
Output		
Connection side		field side
Connection		output I (ETS): terminals 2, 3 output II (DTS): terminals 4, 5, 6 output I and II (DPS): terminals 2, 3, 4, 5, 6
Contact loading		253 V AC/5 A/cos ϕ 0.7; 30 V DC/5 A resistive load
Minimum switch current		2 mA / 24 V DC
Energized/De-energized delay		approx. 10 ms / approx. 5 ms
Mechanical life		5 x 10 ⁶ switching cycles
Fuse rating		2.5 A (max. 5 A) recommended maximum utilization of the fuse: 80 %
Transfer characteristics		
Switching frequency		< 10 Hz
Galvanic isolation		
Input/Output		reinforced insulation according to IEC/EN 61010-1, rated insulation voltage 300 V _{eff}
Output/Output		reinforced insulation according to IEC/EN 61010-1, rated insulation voltage 300 V _{eff}
Indicators/settings		
Display elements		LEDs
Labeling		space for labeling at the front
Directive conformity		
Electromagnetic compatibility		
Directive 2014/30/EU		EN 61326-1:2013 (industrial locations)
Low voltage		
Directive 2014/35/EU		EN 61010-1:2010
Conformity		
Electromagnetic compatibility		NE 21:2012
Degree of protection		IEC 60529:2013
Ambient conditions		
Ambient temperature		-20 ... 60 °C (-4 ... 140 °F) Observe the temperature range limited by derating, see section derating.
Mechanical specifications		
Degree of protection		IP20
Connection		screw terminals
Mass		approx. 100 g
Dimensions		20 x 119 x 115 mm (0.8 x 4.7 x 4.5 inch) (W x H x D) , housing type B2
Mounting		on 35 mm DIN mounting rail acc. to EN 60715:2001
General information		
Supplementary information		Observe the certificates, declarations of conformity, instruction manuals, and manuals where applicable. For information see www.pepperl-fuchs.com .

Assembly

Front view

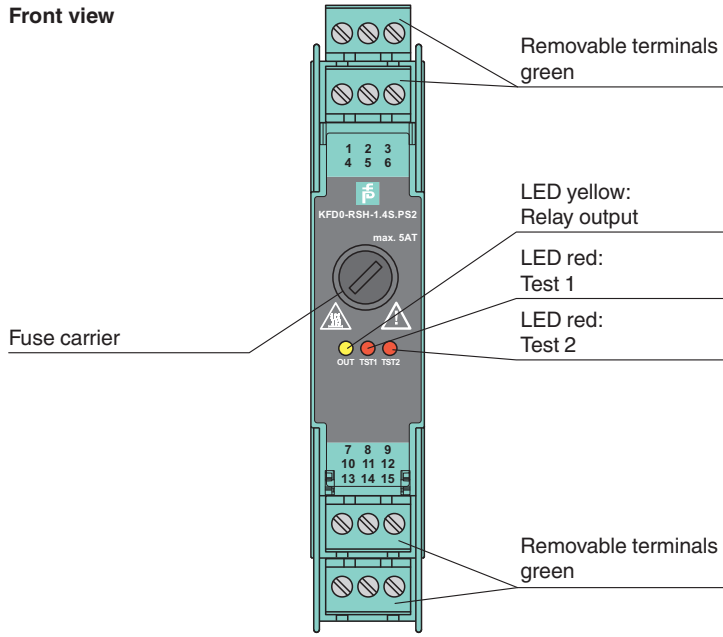

Release date: 2024-09-04 Date of issue: 2024-09-04 Filename: 70132178_eng.pdf

Characteristic Curve

Derating

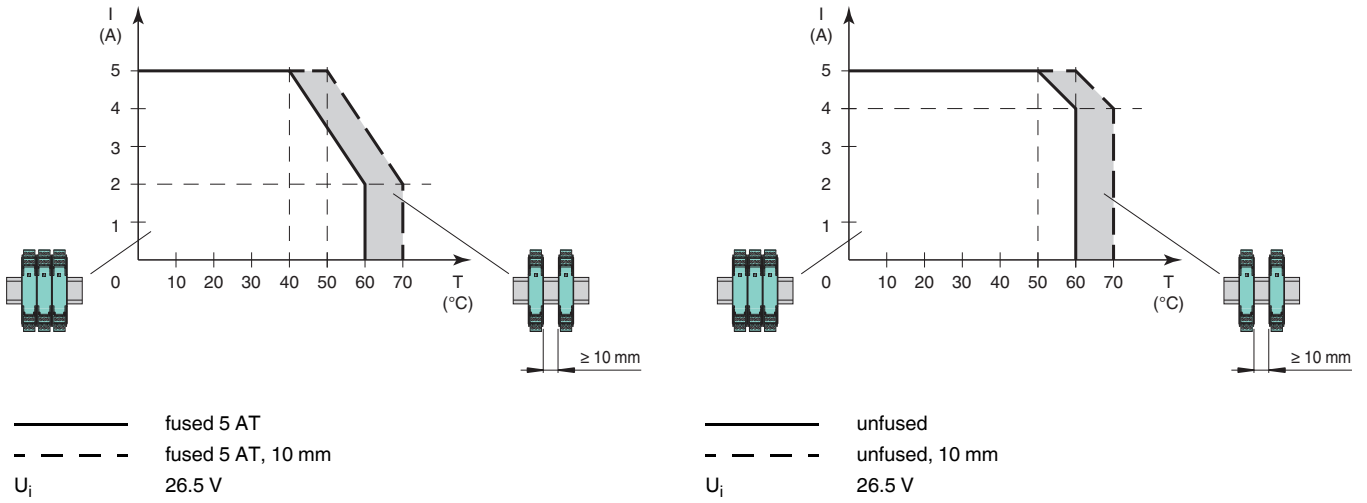

Characteristic Curve

Maximum Switching Power of Output Contacts

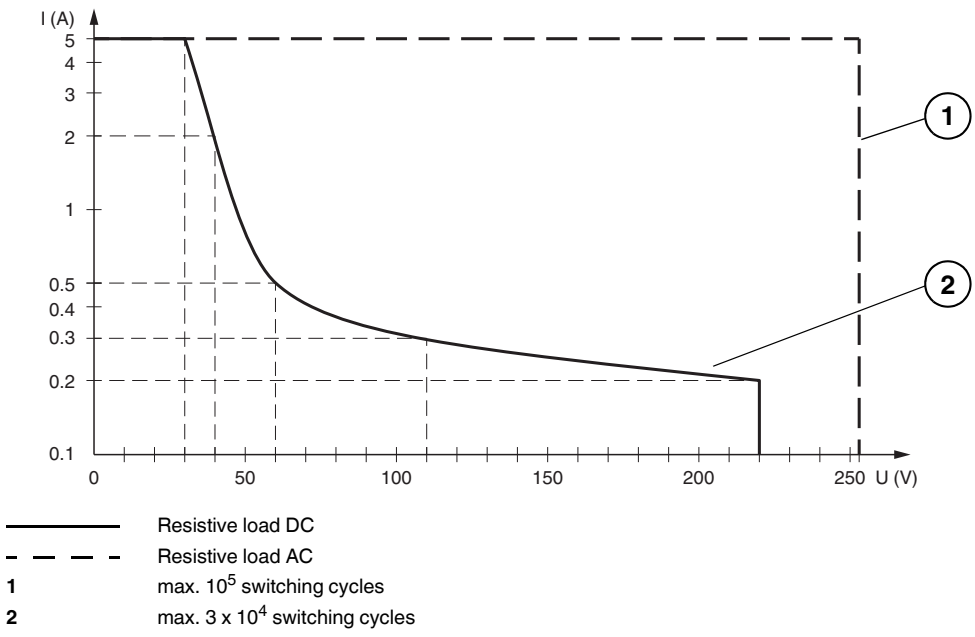

Release date: 2024-09-04 Date of issue: 2024-09-04 Filename: 70132178_eng.pdf