



Solenoid Driver

HiC2883

- 1-channel isolated barrier
- 24 V DC supply (bus or loop powered)
- Output 45 mA at 12 V DC
- Line fault transparency (LFT)
- Test pulse immunity
- Up to SIL 3 acc. to IEC/EN 61508



Function

This isolated barrier is used for intrinsic safety applications. It supplies power to solenoids, LEDs and audible alarms located in a hazardous area. The device is controlled with a loop powered signal or a bus powered logic signal. The device is immune to the test pulses of various control systems. The device simulates a minimum load at the input. The minimum load can be activated and de-activated. The line fault transparency function can display a line fault in the field by a change in impedance at the switching input of the solenoid driver. The line fault transparency function is only available, if the device is supplied via the termination board.

Connection

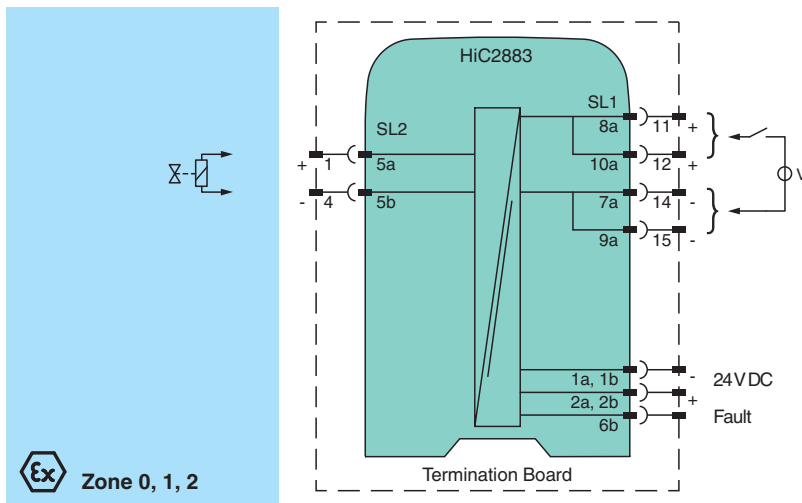

Technical Data

General specifications	
Signal type	Digital Output
Functional safety related parameters	
Safety Integrity Level (SIL)	SIL 3
Systematic capability (SC)	SC 3
Supply	
Connection	SL1: 1a, 1b(-); 2a, 2b(+)
Rated voltage	U _r 19 ... 30 V bus powered via Termination Board 19 ... 30 V loop powered via input , reverse polarity protected
Input current	75 mA at 24 V, 270 Ω load
Power dissipation	1.3 W at 24 V, 270 Ω load

Release date: 2024-08-05 Date of issue: 2024-08-05 Filename: 70140020_eng.pdf

Technical Data

Input		
Connection side		control side
Connection		SL1: 7a(-), 9a(-); 8a(+), 10a(+)
Test pulse length		max. 2 ms from DO card
Signal level		loop powered 1-signal: 19 ... 30 V DC 0-signal: 0 ... 5 V DC bus powered 1-signal: 15 ... 30 V DC (current limited to 5 mA) 0-signal: 0 ... 5 V DC
Rated current	I_r	0-signal: typ. 1.6 mA at 1.5 V DC; typ. 8 mA at 3 V DC (maximum leakage current DO card) 1-signal: ≥ 36 mA (minimum load current DO card)
Inrush current		< 200 mA , 10 ms loop powered
Output		
Connection side		field side
Connection		SL2: 5a(+), 5b(-)
Internal resistor	R_i	approx. 240 Ω
Current	I_e	typ. 45 mA
Voltage	U_e	≥ 12 V
Current limit	I_{max}	50 mA
Open loop voltage	U_s	typ. 24.6 V
Load		nominal 0.05 ... 18 k Ω , valid range for line fault detection (LFD)
Switching frequency	f	max. 10 Hz
Energized/De-energized delay		20 ms / 5 ms
Line fault detection		
Test current		max. 350 μ A , calculated by $I_{LFD} = 4.7 \text{ V} / (15 \text{ k}\Omega + R_{Load})$
Fault indication output		
Connection		SL1: 6b
Output type		open collector transistor (internal fault bus)
Galvanic isolation		
Output/other circuits		basic insulation according to IEC/EN 61010-1, rated insulation voltage 300 V _{eff}
Indicators/settings		
Display elements		LEDs
Control elements		DIP switch
Configuration		via DIP switches
Labeling		space for labeling at the front
Directive conformity		
Electromagnetic compatibility		
Directive 2014/30/EU		EN 61326-1:2013 (industrial locations)
Conformity		
Electromagnetic compatibility		NE 21:2017 , IEC/EN 61326-3-2:2018 For further information see system description.
Degree of protection		IEC 60529:2013
Protection against electrical shock		UL 61010-1:2012
Ambient conditions		
Ambient temperature		-40 ... 70 °C (-40 ... 158 °F)
Mechanical specifications		
Degree of protection		IP20
Mass		approx. 150 g
Dimensions		12.5 x 106 x 128 mm (0.5 x 4.2 x 5.1 inch) (W x H x D)
Mounting		on termination board
Coding		pin 1 and 4 trimmed For further information see system description.
Data for application in connection with hazardous areas		
EU-type examination certificate		FIDI 21 ATEX 0069X

Technical Data

Marking	Ⓢ II 3(1)G Ex nC ec [ia Ga] IIC T4 Gc Ⓢ II (1)D [Ex ia Da] IIIC Ⓢ I (M1) [Ex ia Ma] I	
Output	Ex ia	
Voltage	U_o	26 V
Current	I_o	110 mA
Power	P_o	715 mW
Supply		
Maximum safe voltage	U_m	60 V (Attention! The rated voltage can be lower.)
Input		
Maximum safe voltage	U_m	60 V (Attention! The rated voltage can be lower.)
Galvanic isolation		
Input/Output	safe electrical isolation acc. to IEC/EN 60079-11, rated insulation voltage 300 V _{rms}	
Directive conformity		
Directive 2014/34/EU	EN IEC 60079-0:2018+AC:2020 , EN 60079-7:2015+A1:2018 , EN 60079-11:2012 , EN IEC 60079-15:2019	
International approvals		
FM approval	FM 17 US 0111 X , FM 17 CA 0057 X	
Control drawing	116-0442	
UL approval	E106378	
Control drawing	116-0447A (cULus)	
IECEX approval		
IECEX certificate	IECEX EXA 17.0009X	
IECEX marking	Ex nC ec [ia Ga] IIC T4 Gc [Ex ia Da] IIIC [Ex ia Ma] I	
General information		
Supplementary information	Observe the certificates, declarations of conformity, instruction manuals, and manuals where applicable. For information see www.pepperl-fuchs.com .	

Assembly

Front view

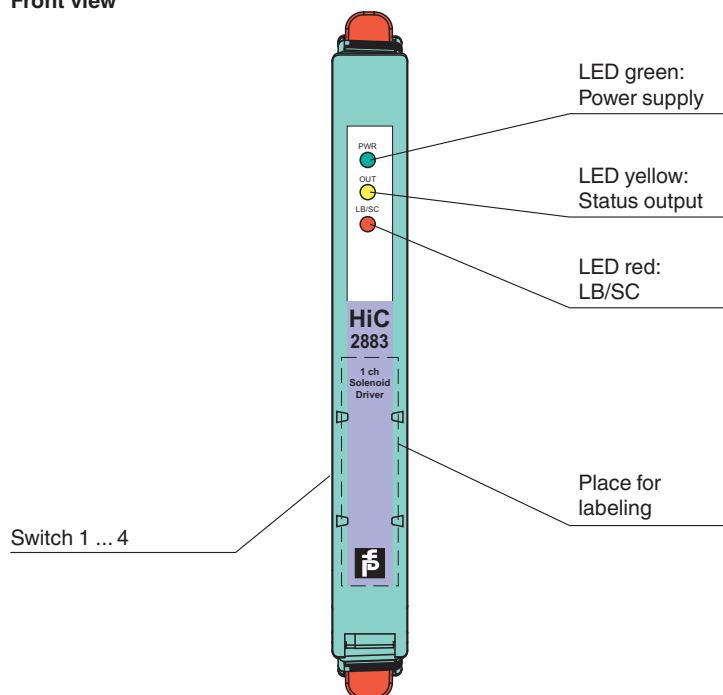

Configuration

Configure the device in the following way:

- Push the red Quick Lok Bars on each side of the device in the upper position.
- Remove the device from termination board.
- Set the switches according to the figure in the **Configuration** section.

Note

The pins for this device are trimmed to polarize it according to its safety parameters. Do not change the setting. For further information see system description.

If the control system DO card does not support the line fault transparency function of the isolator, disable the line fault detection, e. g. Yokogawa Network IO for SIS **S2MMM843/S2MDV843** as style = 1.

Configuration

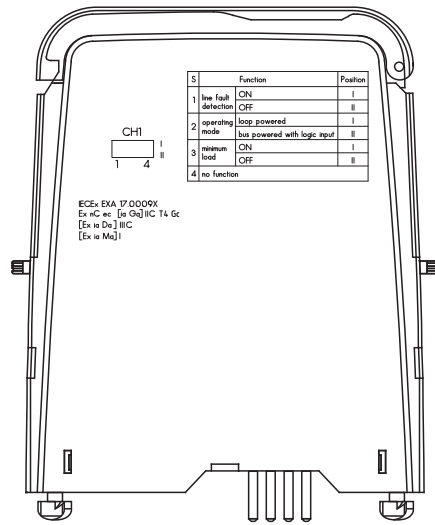

Switch settings

Switch	Function	Position
S1	Line fault detection	enabled
		disabled
S2	Mode of operation	loop powered
		bus powered with logic input
S3	Minimum load	enabled
		disabled
S4	No function	

Factory setting: line fault detection enabled, operating mode loop powered, minimum load enabled

Characteristic Curve

Output characteristics

Output circuit diagram

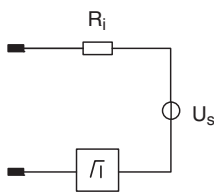

Output characteristic

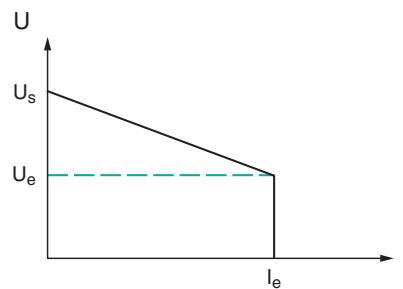

Release date: 2024-08-05 Date of issue: 2024-08-05 Filename: 70140020_eng.pdf