

Vibration sensor

VIM82PU-S1B10-20E-I42WV19

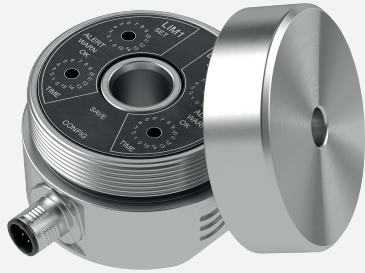

- Suitable for SIL2/PId applications
- Rugged stainless steel housing
- Vibration acceleration in g (rms) acc. to DIN ISO 10816/20816
- Bearing status parameter according to DIN ISO 13373
- 2 relays outputs for safety functions with adjustable switching thresholds, allowing monitoring of a window area

Vibration sensor with safety function both for the analog current output and for the 2 relay outputs with adjustable swiching thresholds



Function

The vibration sensor determines the vibration quantity using rms (root mean square) averaging. This form of quadratic averaging or pre-filtering enables precise trend statements about the condition of the application. The vibration sensor has a safety integrity level (SIL 2) for usage in functional safety applications. For monitoring tasks within the scope of functional safety, 2 relay outputs with adjustable switching thresholds are available. With simultaneous evaluation of both relay outputs by a controller, monitoring of a window area is thus possible, e.g. as part of Condition Monitoring. An additional analog current output provides the bearing status parameter weighted according to DIN ISO 13373. This allows a qualitative assessment of the condition of rolling-element bearings.

Dimensions

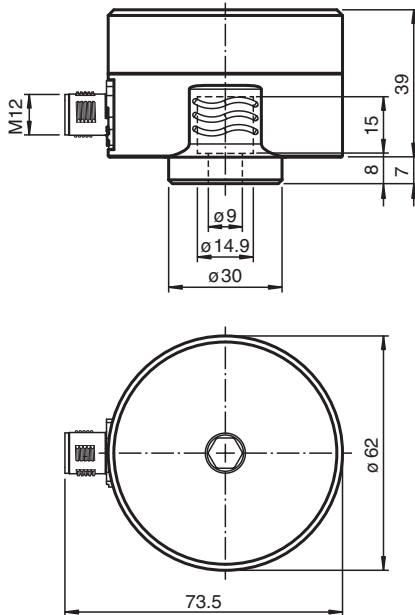

Technical Data

General specifications

Type	Vibration sensor
Measuring technology	MEMS

Release date: 2024-05-21 Date of issue: 2024-05-21 Filename: 70141684-100005_eng.pdf

Technical Data

Series	Pure Line	
Measured variable		Vibration acceleration Bearing status parameter
Measurement range		
Vibration acceleration	a-rms	0 ... 10 g rms
Bearing status parameter		1 ... 4 see section characteristic curve
Measurement accuracy		± 0.01 g (calibration point: 90% of the measuring range; 159.2 Hz) Complies with the tolerance requirements of DIN ISO 2954
Cross-sensitivity		< 5 % of the partial lateral acceleration, which acts exactly 90° to the measuring axis
Frequency range		10 ... 1000 Hz
Averaging time		for a-rms: 2 s
Functional safety related parameters		
Safety Integrity Level (SIL)		SIL 2
Performance level (PL)		PL d
Category		Cat. 2
MTTF _d		329 a
Mission Time (T _M)		10 a
Diagnostic Coverage (DC)		min. 90 %
Indicators/operating means		
Status indicator		6 LEDs for operating states
Control elements		4 rotary switches and 1 push button for programming
Electrical specifications		
Fusing		external fuse is required: 3 A , semi-time-lag , 30 V DC
Operating voltage	U _B	24 V DC + 7 % / - 10 %
Current consumption		max. 100 mA
Power consumption	P ₀	2.6 W
Time delay before availability	t _v	15 s (initially self-test functions are executed before safe measured values are available at the output)
Surge protection		up to 2 kV
Output 1		
Output type		relay
Switching function		Normally open (NO)
Switching voltage		max. 30 V DC
Switching current		max. 1 A
Output 2		
Output type		relay
Switching function		Normally open (NO)
Switching voltage		max. 30 V DC
Switching current		max. 1 A
Output 3		
Output type		analog output, current output of the vibration variable
Output current		4 ... 20 mA
Load resistor		≤ 500 Ω
Output 4		
Output type		analog output, current output of the bearing status parameter
Output current		4 ... 20 mA (bearing status parameter according to DIN ISO 13373-3, see section characteristic curve) with steps: 1 = 4 ... 8 mA 2 = 8 ... 12 mA 3 = 12 ... 16 mA 4 = 16 ... 20 mA
Load resistor		≤ 500 Ω
Standard conformity		

Technical Data

Degree of protection	DIN EN 60529, IP66, IP67
Shock resistance	DIN EN 60068-2-27, 60 g, 6 ms
Vibration resistance	DIN EN 60068-2-6, 16.5 g, 10 ... 1000 Hz
Vibration evaluation	DIN ISO 10816/20816
Functional safety	DIN EN IEC 61508 , SIL 2 EN ISO 13849 , PL d
Approvals and certificates	
UL approval	
Ordinary Location	E468231 cULus Listed, Class III Power Source and limited energy , if UL marking is marked on the product. For use in NFPA 70 Applications only. adapters providing field wiring on request
Maximum permissible ambient temperature	max. 60 °C (max. 140 °F)
Ambient conditions	
Ambient temperature	-40 ... 60 °C (-40 ... 140 °F)
Measuring head temperature	-40 ... 85 °C (-40 ... 185 °F) directly at the mounting point
Storage temperature	-40 ... 60 °C (-40 ... 140 °F)
Mechanical specifications	
Connection type	plug
Housing material	Stainless steel 1.4305 / AISI 303
Degree of protection	IP66 / IP67 only in connected state and correctly mounted housing cover
Connector	
Threading	M12
Number of pins	8
Mass	approx. 500 g
Dimensions	
Height	46 mm
Width	62 mm
Length	73.5 mm
General information	
Scope of delivery	1 x allen head screw M8 x 20 1 x spring washer M8 1 x seal label

Connection

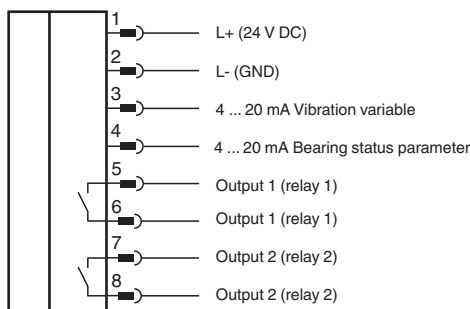

Accessories

Accessories for this product can be found on the internet at www.pepperl-fuchs.com.

Installation

Further Documentation

The sensor manual is also available as detailed overall documentation. Among other things, installation, grounding concepts and mounting are described there in detail.

You can access the manual via the product detail page at www.pepperl-fuchs.com.

Note

The correct electrical connection and the selection of the appropriate grounding concept are crucial for malfunction-free operation of the sensor. For detailed information you may refer to the manual of the sensor.

Characteristic Curve

Bearing status parameter dependent on vibration

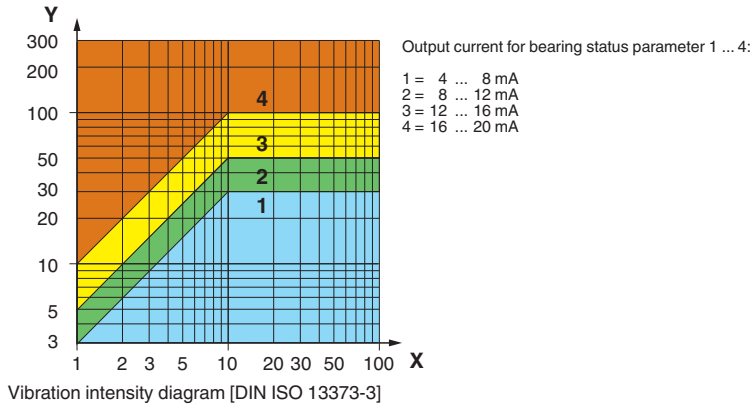

Adjustable relay outputs

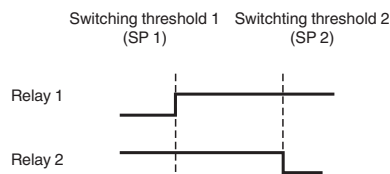

critical state = out of window (SP1, SP2) = relay is open = like de-energized state

Release date: 2024-05-21 Date of issue: 2024-05-21 Filename: 70141684-100005_eng.pdf