

Active infrared scanner

PROSCAN-T-8883

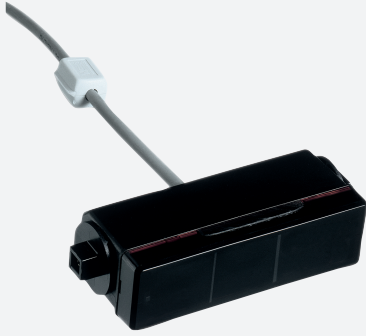

- Fan-shaped detection field with up to 12 beams
- Adjustable detection fields for different door widths
- Preset version
- Version with switches determine sensing field
- Automatic drift compensation
- Version with E1 approval

Multi-beam sensor with self-programming function for monitoring large areas with e1 approval



Function

The compact ProScan energetic light scanner operates using an integrated source of infrared light and creates a fan-shaped detection field consisting of a maximum of 12 independent light beams. Since the beam intensifies toward the center of the fan, the area around the closing edges in particular is monitored virtually seamlessly. The sensors are self-programming and automatically adapt to any environment, learn the environment, and even automatically adapt to subsequent changes. Other notable features include the high level of sensitivity, ambient light immunity and compensation of long-term drift. This function guarantees reliable long-term use, even in dirty, rainy or snowy conditions.

Application

- Closing edge protection on automatic sliding doors, for example, sliding doors in shopping centers, public buildings, and office buildings
- **Version T with e1 approval:** closing edge protection on automatic doors on public transport vehicles, such as buses and trains
- Threshold monitoring on revolving doors

Dimensions

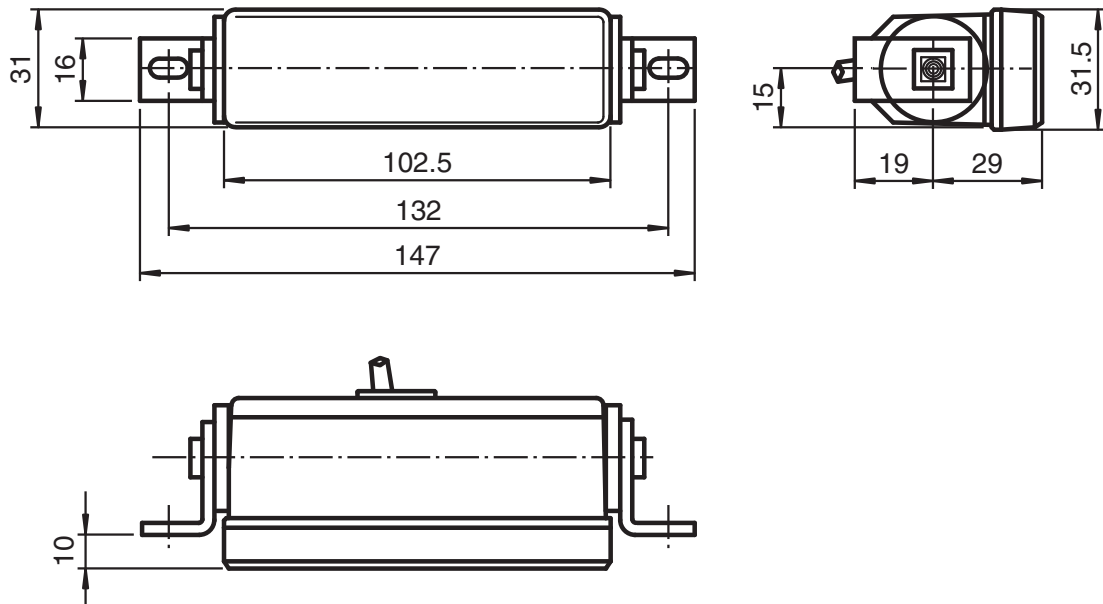

Technical Data

General specifications	
Detection field	80 mm x 80 mm , switchable 550 mm x 80 mm
Light source	12 x IRED
Light type	modulated infrared light
Teach-in time	approx. 4 s
Number of beams	1 light beam , switchable to 4 beams
Open time	3 s / 10 s, programmable
Functional safety related parameters	
MTTF _d	630 a
Mission Time (T _M)	20 a
Diagnostic Coverage (DC)	60 %
Indicators/operating means	
Function indicator	LED red: on for object detection, flashes during teaching phase
Control elements	Programmable switch for switching type, open time, detection field
Electrical specifications	
Operating voltage	U _B 12 ... 38 V DC
Ripple	10 %
No-load supply current	I ₀ 100 mA
Input	
Control input	0 V = small detection field / +U _B = great detection field
Output	
Switching type	Output active / inactive programmable

Release date: 2023-04-05 Date of issue: 2023-04-05 Filename: 70143359_eng.pdf

Technical Data

Signal output		1 PNP, short-circuit protected, reverse polarity protected, open collector
Switching voltage		38 V DC
Switching current		200 mA
Response time		< 50 ms
De-energized delay	t_{off}	200 ms
Compliance with standards and directives		
Standard conformity		
Product standard		EN 60947-5-2
Standards		EN 50155 Chapter 12.2.3 / 12.2.5 / 12.2.7 / 12.2.8 / 12.2.11 / 12.2.14 Details see test report
Flammability		Flame retardant in accordance with UN/ECE-R118 or ISO 14572
Approvals and certificates		
UN/ECE Regulation No. 10 (E1)		Type-approval number: 046982
Ambient conditions		
Ambient temperature		-25 ... 60 °C (-13 ... 140 °F)
Storage temperature		-40 ... 70 °C (-40 ... 158 °F)
Mechanical specifications		
Mounting height		1000 ... 2500 mm
Degree of protection		IP52
Connection		AMP connector 6-pin , 2 m fixed cable
Material		
Housing		ABS
Optical face		PMMA
Mass		approx. 100 g
Factory settings		
Function		
DIP switch		1 / 2 : ON / ON
Detection field		80 mm x 80 mm , 1 light beam (central left light beam)
Input		Control input (SE) : 0 V = small detection field

Connection Assignment

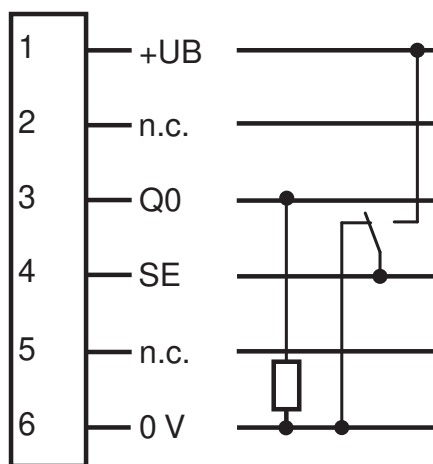

Assembly

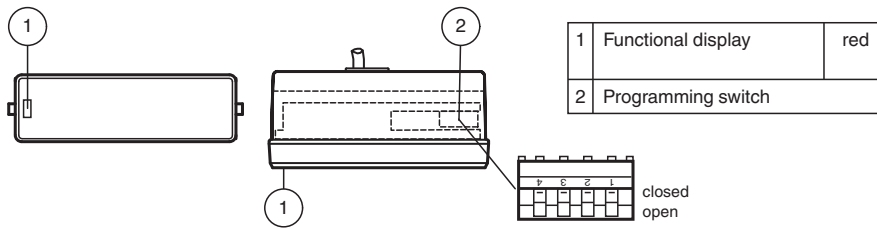

Characteristic Curve

Timing diagram Proscan

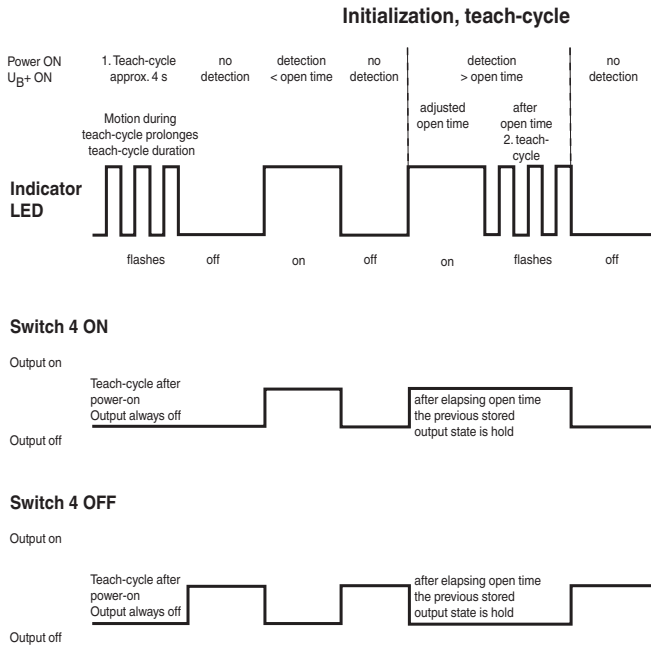

Characteristic Curve

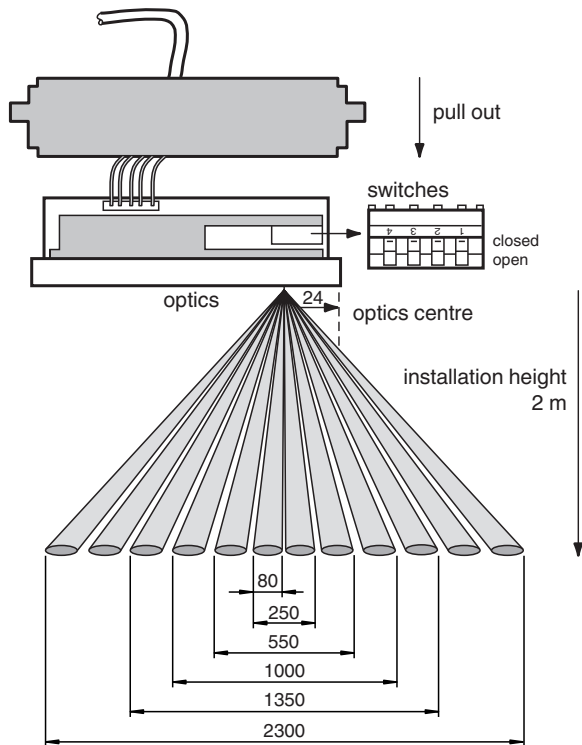

Application



Function Principle

The ProScan is a 12-beam energetic light scanner based on the principles of active infrared. The beams, which are switched independently, enable the sensor to fan out across an extremely wide and narrow detection field in the area of the door. The clearly defined, fan-shaped detection field on the ProScan can be set manually in four areas: half fan to the right, half fan to the left, central fan and full detection field.

Immediately after being switched on for the first time, the ProScan programs the reflected pattern of the detected background as the reference signal. During this process, the ProScan automatically adapts to the relevant installation and assembly environment. Since each of the individual light beams on the ProScan independently programs its specific reception level, there is no need to manually configure complex sensitivity settings. Once the programming phase is complete, the light reflected from each of the 12 light beams is evaluated. Each time there is a difference between the reflected value of an individual light beam and the reference signal, a switching process is initiated.

Release date: 2023-04-05 Date of issue: 2023-04-05 Filename: 70143359_eng.pdf

Programming

The programming switch can be accessed by carefully removing the cover with the lens assembly from the housing. A small slot-head screwdriver can be used to carefully lift off the cover by the slots located on the sides of the cover.

Each switch is on when the switch position is down (ON); if the switch position is up, then the switch is switched off (OFF).

Programming options

Switch	Output active during detection	Output inactive during detection	Open Time 10 s	Open Time PROSCAN 3 min PROSCAN-T 3 s
4	ON	OFF		
3			ON	OFF

Detection field at installation height 2000 mm

Control input	+UB	2300 mm x 80 mm Full field	1350 mm x 80 mm Center field	1000 mm x 80 mm Center field	550 mm x 80 mm Center field
	0 V	250 mm x 80 mm Center field	250 mm x 80 mm Center field	550 mm x 80 mm Center field	80 mm x 80 mm Left central light beam
Switch	2	OFF	ON	OFF	ON
	1	OFF	OFF	ON	ON

Technical Features

"Open Time" Function

The ProScan is a self-programming device, and automatically adjusts to changes in its environment. If the ProScan detects a stationary object that does not correspond to the programmed reference signal (for example, a suitcase), ProScan interprets this as a permanent change in the environment and initiates a new self teach-in process after a preset time (referred to as "Open Time") has elapsed. Open Time can be adjusted to meet customer application requirements.

"Suitcase" Function

After a background has been changed, the ProScan "Suitcase" function allows the reference to be adjusted back to the original background. Once a self-taught object, such as a suitcase, is removed from the detection field again, ProScan returns to the original reference. A new learning process is not required.

Compensating for long-term drifts

The ProScan is able to compensate for long-term drifts. Using this function, changes to the ground reflectance (for example, caused by rain or snow), as well as temperature fluctuations and dirt on the optical surface or ground are automatically compensated for.

Test input (optional)

Using the integrated test input, the overall function of the ProScan can be reliably checked by testing all 12 light beams simultaneously.

Accessories

	UP-Einbaurahmen	Mounting frame for sensors in the AIR30 and PROSCAN series
---	------------------------	--