



Inductive sensor NJ60-FP-E2-P2

- 3-wire DC
- Surface mount
- Sensing range 60 mm
- Operating distance adjustable via potentiometer



Dimensions

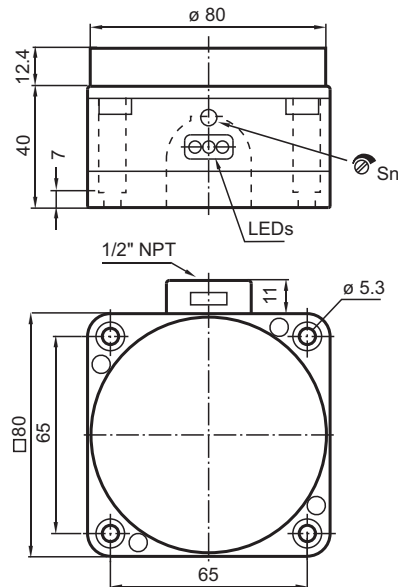

Technical Data

General specifications

Switching function		Normally open (NO)
Output type		PNP
Rated operating distance	s_n	60 mm
Installation		non-flush
Output polarity		DC
Assured operating distance	s_a	0 ... 48.6 mm

Release date: 2024-05-27 Date of issue: 2024-05-27 Filename: 70147100_eng.pdf

Technical Data

Reduction factor r_{Al}		0.4
Reduction factor r_{Cu}		0.3
Reduction factor r_{304}		0.85
Output type		3-wire
Adjustment aid		LED, green/red
Nominal ratings		
Operating voltage	U_B	10 ... 30 V
Switching frequency	f	8 Hz
Hysteresis	H	typ. 3 %
Reverse polarity protection		reverse polarity protected
Short-circuit protection		pulsing
Voltage drop	U_d	≤ 3 V
Operating current	I_L	0 ... 200 mA
No-load supply current	I_0	≤ 20 mA
Time delay before availability	t_v	≤ 20 ms
Operating voltage indicator		LED, green
Switching state indicator		LED, red
Compliance with standards and directives		
Standard conformity		
Standards		EN IEC 60947-5-2
Approvals and certificates		
UL approval		cULus Listed, General Purpose
CSA approval		cCSAus Listed, General Purpose
Ambient conditions		
Ambient temperature		0 ... 60 °C (32 ... 140 °F)
Mechanical specifications		
Connection type		screw terminals
Core cross section		up to 2.5 mm ²
Housing material		POM
Sensing face		POM
Degree of protection		IP65
Dimensions		
Height		40 mm
Width		80 mm
Length		80 mm

Connection

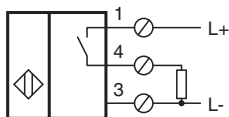

Mounting

Installation

The sensor should be mounted at least 30 mm above the conveyor chain. This ensures, that the sensor will not be influenced by the conveyor chain.

Adjustment:

For correct operation, the sensor has to be adjusted according to the application.

The adjustment has to be carried out without the object, which has to be detected.

- 1) Supply the sensor (10 ... 30 V DC).
leuchtet die grüne LED.
- 2) If the output is activated,
the yellow LED is on
- 3) The adjustment is made without
measuring body

The double LED in the middle has to light up green. If it doesn't, turn the sensitivity adjuster clockwise until the LED lights up yellow. Now turn the sensitivity adjuster counterclockwise until the double LED lights up green.

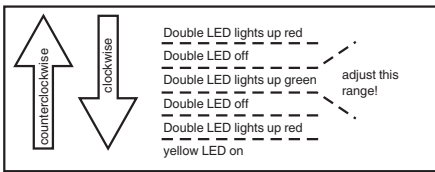
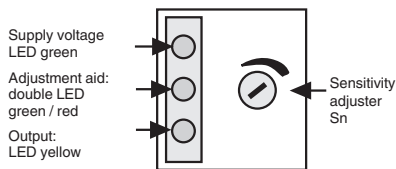

Function check:

To check the correct adjustment, test the reliable detection of a stainless steel test tube in the bottle.