

Ultrasonic sensor

UB300-18GM40A-I-V1-Y70147387

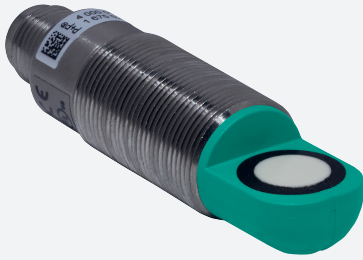

- Short design, 40 mm
- Analog output 4 mA ... 20 mA
- Measuring window adjustable
- Program input
- Temperature compensation
- Stainless steel version

Single head system



Dimensions

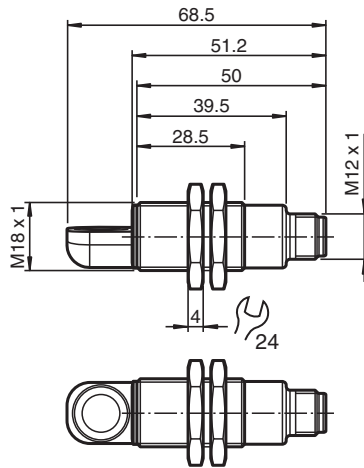

Technical Data

General specifications		
Sensing range		35 ... 300 mm
Adjustment range		50 ... 300 mm
Dead band		0 ... 35 mm
Standard target plate		100 mm x 100 mm
Transducer frequency		approx. 390 kHz
Response delay		approx. 50 ms
Electrical specifications		
Operating voltage	U_B	10 ... 30 V DC , ripple 10 % _{SS}
No-load supply current	I_0	≤ 20 mA
Input		
Input type		1 program input lower evaluation limit A1: $-U_B ... +1$ V, upper evaluation limit A2: $+4$ V ... $+U_B$ input impedance: > 4.7 kΩ, pulse duration: ≥ 1 s
Output		
Output type		1 analog output 4 ... 20 mA
Default setting		evaluation limit A1: 50 mm evaluation limit A2: 300 mm
Resolution		0.4 mm at max. sensing range

Release date: 2025-05-16 Date of issue: 2025-05-16 Filename: 70147387_eng.pdf

Technical Data

Deviation of the characteristic curve	± 1 % of full-scale value
Repeat accuracy	± 0.5 % of full-scale value
Load impedance	0 ... 300 Ohm
Temperature influence	± 1.5 % of full-scale value
Compliance with standards and directives	
Standard conformity	
Standards	EN IEC 60947-5-2:2020 IEC 60947-5-2:2019 EN 60947-5-7:2003 IEC 60947-5-7:2003
Approvals and certificates	
UL approval	cULus Listed, Class 2 Power Source
CCC approval	CCC approval / marking not required for products rated ≤36 V
Ambient conditions	
Ambient temperature	-25 ... 70 °C (-13 ... 158 °F)
Storage temperature	-40 ... 85 °C (-40 ... 185 °F)
Mechanical specifications	
Connection type	Connector plug M12 x 1 , 4-pin , metal
Degree of protection	IP67
Material	
Housing	Stainless steel 1.4305 / AISI 303
Transducer	epoxy resin/hollow glass sphere mixture; foam polyurethane, cover PBT
Mass	25 g
Dimensions	
Length	40 mm
Diameter	18 mm

Connection Assignment

Standard symbol/Connections:
(version I)

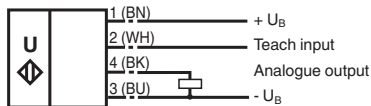

Core colours in accordance with EN 60947-5-2.

Connection Assignment

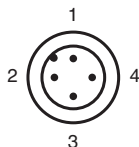

Wire colors in accordance with EN 60947-5-2

- | | | | |
|---|--|----|---------|
| 1 | | BN | (brown) |
| 2 | | WH | (white) |
| 3 | | BU | (blue) |
| 4 | | BK | (black) |

Release date: 2025-05-16 Date of issue: 2025-05-16 Filename: 70147387_eng.pdf

Characteristic Curve

Characteristic response curve

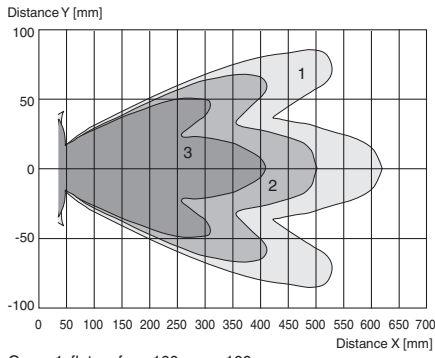

Curve 1: flat surface 100 mm x 100 mm
Curve 2: flat surface 10 mm x 10 mm
Curve 3: round bar, Ø 25 mm



Programming the analog output mode

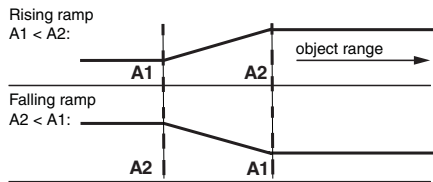

Release date: 2025-05-16 Date of issue: 2025-05-16 Filename: 70147387_eng.pdf

Programming

Programming procedure

The sensor features a programmable analog output with two programmable evaluation boundaries. Programming the evaluation boundaries and the operating mode is done by applying the supply voltage $-U_B$ or $+U_B$ to the Teach-In input. The supply voltage must be applied to the Teach-In input for at least 1 s. LEDs indicate whether the sensor has recognized the target during the programming procedure.

Note:

Evaluation boundaries may only be specified directly after Power on. A time lock secures the adjusted switching points against unintended modification 5 minutes after Power on. To modify the evaluation boundaries later, the user may specify the desired values only after a new Power On.

Note:

If a programming adapter UB-PROG2 is used for the programming procedure, button A1 is assigned to $-U_B$ and button A2 is assigned to $+U_B$.

Programming the analog output

Rising ramp

1. Place the target at the near end of the desired evaluation range
2. Program the evaluation boundary by applying $-U_B$ to the Teach-In input (yellow LED flashes)
3. Disconnect the Teach-In input from $-U_B$ to save the evaluation boundary
4. Place the target at the far end of the desired evaluation range
5. Program the evaluation boundary by applying $+U_B$ to the Teach-In input (yellow LED flashes)
6. Disconnect the Teach-In input from $+U_B$ to save the evaluation boundary

Falling ramp

1. Place the target at the far end of the desired evaluation range
2. Program the evaluation boundary by applying $-U_B$ to the Teach-In input (yellow LED flashes)
3. Disconnect the Teach-In input from $-U_B$ to save the evaluation boundary
4. Place the target at the near end of the desired evaluation range
5. Program the evaluation boundary by applying $+U_B$ to the Teach-In input (yellow LED flashes)
6. Disconnect the Teach-In input from $+U_B$ to save the evaluation boundary