



Mounting bracket USI-MH-27X13-V-02

- Screw mounting for simple installation
- Robust construction

Vertical mounting bracket exclusively for ultrasonic transducers of the USi ultrasonic sensor systems

Dimensions

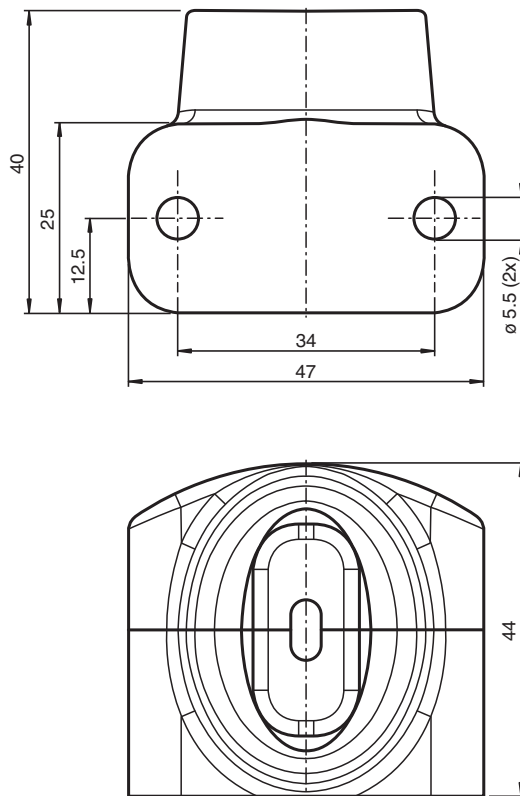

Technical Data

Ambient conditions

Ambient temperature	-40 ... 80 °C (-40 ... 176 °F)
Storage temperature	-40 ... 85 °C (-40 ... 185 °F)

Technical Data

Mechanical specifications

Material	
Housing	PA12
Mounting materials	2 x cylinder head screw M5x16 (included with delivery) 2 x cylinder head screw M3x10 (included with delivery)
Tightening torque, fastening screws	for screw M5 : max. 1.5 Nm for screw M3 : max. 0.5 Nm
Dimensions	40 mm x 47 mm x 44 mm
Height	44 mm
Width	47 mm
Length	40 mm

Commissioning

This component is only intended for use in conjunction with the ultrasonic sensor system USi-safety or USi-industry. Further details, mounting and commissioning instructions can be found in the corresponding documentation on the relevant product page at www.pepperl-fuchs.com.