



Surge Protection Barrier

M-LB-4282

- Surge protection for 2 signal lines
- Nominal voltage 230 V
- Surge protection barrier for non-grounded signal lines
- Max. surge current (8/20 μ s) 6 kA
- Uninterruptable operation (auto reset)
- Status indication
- Modular design, pluggable
- Up to SIL 3 acc. to IEC/EN 61508

CE SIL3

Function

The device limits induced transients of different causes, e. g. lightning or switching operations. The limitation is achieved by diverting the current to earth and limiting the signal loop voltage during the duration of the overvoltage pulse. The device consists of base module and protection module. The protection module can be replaced without tools. The device has a status indication at the front. The device is mounted on a 35 mm DIN mounting rail according to EN 60715.

Connection

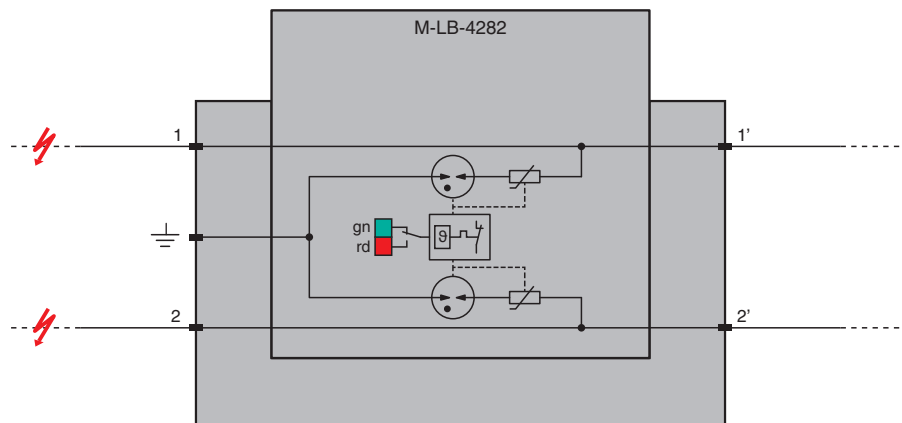

Zone 2

Technical Data

General specifications

Number of protected signal lines	2
Topology	non-grounded

Functional safety related parameters

Safety Integrity Level (SIL)	SIL 3
------------------------------	-------

Electrical specifications

Connection	protected area: terminals 1', 2' unprotected area: terminals 1, 2
Leakage current	< 50 nA bei U_c , line-line < 50 nA bei U_c , line-earth
Nominal voltage	230 V
Maximum continuous operating voltage	U_c 250 V AC and 320 V DC

Technical Data

Nominal load current	I_L	3 A at 80 °C (176 °F)
Series resistance		0 Ω per line
Impulse discharge current (10/350 μ s)	I_{imp}	0.5 kA per line
Nominal discharge current (8/20 μ s)	I_n	3 kA per line
Total discharge current (8/20 μ s)	I_{total}	6 kA
Voltage protection level	U_p	max. 1100 V line-earth for nominal discharge current I_n
Impulse reset time		< 30 ms
Cut-off frequency	f_G	200 MHz , line-line
Indicators/settings		
Display elements		status display operating state (green) fault indication (red)
Conformity		
Degree of protection		IEC 60529:2013
Functional safety		IEC/EN 61508:2010
Surge protective devices for low voltage		EN 61643-21:2001+A1:2009+A2:2013 IEC 61643-21:2001+A1:2008+A2:2012
Ambient conditions		
Ambient temperature		-40 ... 80 °C (-40 ... 176 °F)
Storage temperature		-40 ... 80 °C (-40 ... 176 °F)
Relative humidity		max. 95 % , without condensation
Corrosion resistance		acc. to ISA-S71.04, severity level G3
Mechanical specifications		
Degree of protection		IP20
Connection		spring terminals with push-in connection technology
Core cross section		0.2 ... 2.5 mm ² one wire 0.2 ... 2.5 mm ² fine-strand
Material		
Housing		Polyamide PA 6.6
Mass		approx. 40 g
Dimensions		6 x 90 x 69 mm (0.24 x 3.5 x 2.7 inch) (W x H x D)
Mounting		on 35 mm DIN mounting rail acc. to EN 60715:2001
General information		
Supplementary information		Observe the certificates, declarations of conformity, instruction manuals, and manuals where applicable. For information see www.pepperl-fuchs.com .

Assembly

Front view

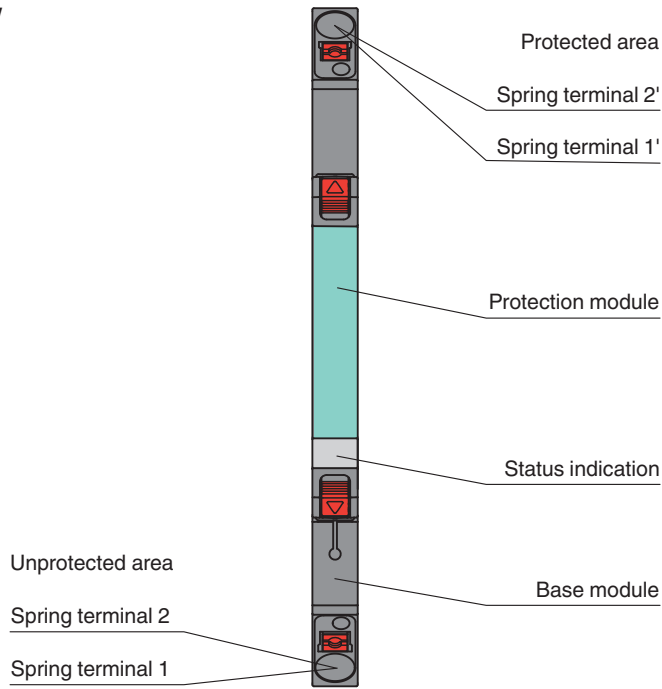

Matching System Components

	M-LB-4400	Fault Status Module
---	------------------	---------------------

Accessories

	M-LB-4800	Separation Wall
---	------------------	-----------------

Release date: 2023-06-20 Date of issue: 2023-06-20 Filename: 70155088_eng.pdf