



Protection Module for Surge Protection Barrier

M-LB-4214.M

- Protection module for 2 signal lines
- Nominal voltage 5 V
- Protection module for grounded signal lines
- Max. surge current (8/20 μ s) 20 kA
- Uninterruptable operation (auto reset)
- Status indication
- Mounting on base module, pluggable
- Up to SIL 3 acc. to IEC/EN 61508



Function

The protection module limits induced transients of different causes, e. g. lightning or switching operations. The limitation is achieved by diverting the current to earth and limiting the signal circuit voltage during the duration of the overvoltage pulse. The device is a spare part for the corresponding 2-part surge protection barrier. The device is not to be used as a stand-alone device. The device has a status indication at the front. The device can be replaced without tools by locking levers.

Connection

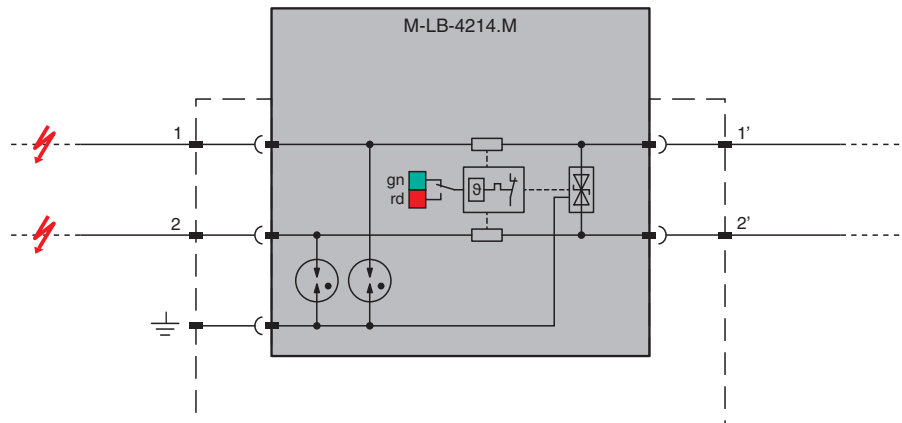

Zone 2

Technical Data

General specifications

Number of protected signal lines	2
Topology	grounded

Functional safety related parameters

Safety Integrity Level (SIL)	SIL 3
------------------------------	-------

Electrical specifications

Connection	via base module
Leakage current	< 5 μ A bei U_c , line-line < 5 μ A bei U_c , line-earth
Nominal voltage	5 V
Maximum continuous operating voltage	U_c 6 V AC and 8.5 V DC
Nominal load current	I_L 0.75 A at 70 °C (158 °F)

Release date: 2023-06-20 Date of issue: 2023-06-20 Filename: 70155090_eng.pdf

Technical Data

Series resistance		1 Ω per line
Impulse discharge current (10/350 μ s)	I_{imp}	1.5 kA per line
Nominal discharge current (8/20 μ s)	I_n	5 kA per line
Max. surge current (8/20 μ s)	I_{max}	20 kA
Total discharge current (8/20 μ s)	I_{total}	10 kA
Voltage protection level	U_p	max. 50 V line-line for nominal discharge current I_n max. 70 V line-earth for nominal discharge current I_n
Impulse reset time		< 30 ms
Cut-off frequency	f_G	100 MHz , line-line
Indicators/settings		
Display elements		status display operating state (green) fault indication (red)
Conformity		
Degree of protection		IEC 60529:2013
Functional safety		IEC/EN 61508:2010
Surge protective devices for low voltage		EN 61643-21:2001+A1:2009+A2:2013 IEC 61643-21:2001+A1:2008+A2:2012
Ambient conditions		
Ambient temperature		-40 ... 80 °C (-40 ... 176 °F)
Storage temperature		-40 ... 80 °C (-40 ... 176 °F)
Relative humidity		max. 95 % , without condensation
Corrosion resistance		acc. to ISA-S71.04, severity level G3
Mechanical specifications		
Degree of protection		IP20
Connection		via base module
Material		
Housing		Polyamide PA 6.6
Mass		approx. 14 g
Dimensions		6 x 45 x 54 mm (0.24 x 1.77 x 2.15 inch) (W x H x D)
Mounting		pluggable in base module for mounting on 35 mm DIN mounting rail
Data for application in connection with hazardous areas		
Certificate		TÜV 22 ATEX 8881 X
Marking		Ⓜ II 3G Ex ec IIC T4 Gc
Temperature class		T4 for ambient temperature \leq 80 °C
Directive conformity		
Directive 2014/34/EU		EN 60079-0:2018 , EN IEC 60079-7:2015+A1:2018
International approvals		
UL approval		E501704
IECEX approval		
IECEX certificate		IECEX TUR 22.0051X
IECEX marking		Ex ec IIC T4 Gc
General information		
Supplementary information		Observe the certificates, declarations of conformity, instruction manuals, and manuals where applicable. For information see www.pepperl-fuchs.com .

Assembly

Front view

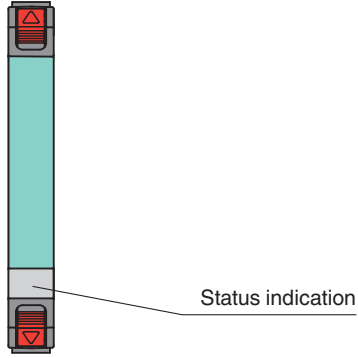

Release date: 2023-06-20 Date of issue: 2023-06-20 Filename: 70155090_eng.pdf