



Temperature Converter

HiC2081

- 1-channel isolated barrier
- 24 V DC supply (bus powered)
- Thermocouple, RTD, potentiometer or voltage input
- Linearized output 4 mA ... 20 mA, sink/source
- Sensor breakage detection
- Configurable by PACTware
- Line fault detection (LFD)
- Up to SIL 2 acc. to IEC/EN 61508



Function

This isolated barrier is used for intrinsic safety applications. This device accepts thermocouples (TC), millivolts, potentiometers, or resistance temperature detectors (RTD) from a hazardous area and converts them to an isolated, linearized analog output in the safe area. The output can be selected as a current source or current sink with a switch. Line fault detection of the field circuit is indicated by a red LED and an output on the fault bus. The fault conditions are monitored via a Fault Indication Board. The device is easily configured by the use of the PACTware configuration software. This device mounts on a HiC Termination Board.

Application

The resistance thermometer for cold junction compensation H-CJC-* is available as an accessory for temperature measurements with thermocouples.

Connection

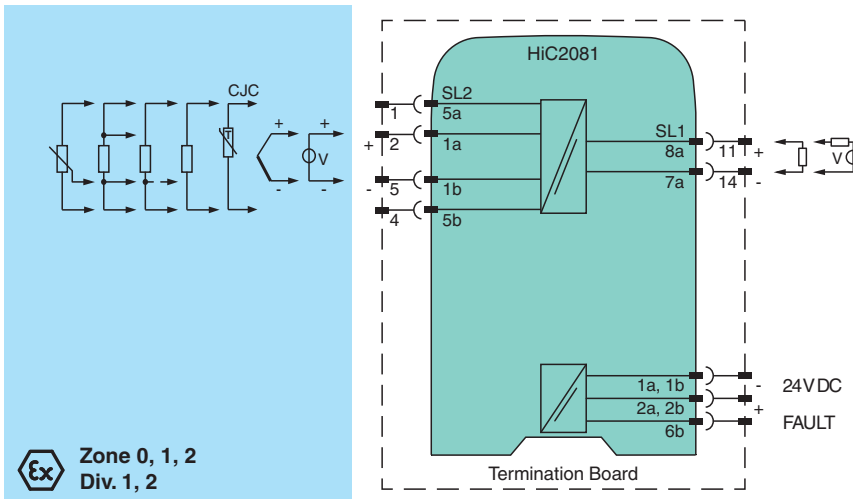

Ex Zone 0, 1, 2
Div. 1, 2

Technical Data

General specifications	
Signal type	Analog input
Functional safety related parameters	
Safety Integrity Level (SIL)	SIL 2
Supply	
Connection	SL1: 1a, 1b(-); 2a, 2b(+)

Release date: 2023-06-05 Date of issue: 2023-06-05 Filename: 70159064_eng.pdf

Technical Data

Rated voltage	U_r	20 ... 30 V DC bus powered via Termination Board
Ripple		within the supply tolerance
Power dissipation		≤ 0.98 W
Power consumption		max. 0.98 W
Interface		
Programming interface		programming socket
Input		
Connection side		field side
Connection		SL2: 5a(+), 1a(+), 1b(-), 5b(-)
RTD		type Pt10, Pt50, Pt100, Pt500, Pt1000 (EN 60751: 1995) type Pt10GOST, Pt50GOST, Pt100GOST, Pt500GOST, Pt1000GOST (6651-94) type Cu10, Cu50, Cu100 (P50353-92) type Ni100 (DIN 43760)
Measuring current		approx. 200 μ A with RTD
Types of measuring		2-, 3-, 4-wire connection
Lead resistance		max. 50 Ω per line
Measurement loop monitoring		sensor breakage, sensor short-circuit
Thermocouples		type B, E, J, K, N, R, S, T (IEC 584-1: 1995) type L (DIN 43710: 1985) type TXK, TXKH, TXA (P8.585-2001)
Cold junction compensation		external and internal
Measurement loop monitoring		sensor breakage
Potentiometer		0 ... 20 k Ω (2-wire connection), 0.8 ... 20 k Ω (3-wire connection)
Types of measuring		3-wire connection
Voltage		selectable within the range -100 ... 100 mV
Input resistance		≥ 1 M Ω (-100 ... 100 mV)
Output		
Connection side		control side
Connection		SL1: 8a(+), 7a(-)
Output		Analog current output
Current range		0 ... 20 mA or 4 ... 20 mA
Fault signal		downscale 0 or 2 mA, upscale 21.5 mA (acc. NAMUR NE43)
Source		load 0 ... 550 Ω open-circuit voltage ≤ 18 V
Sink		Voltage across terminals 5 ... 30 V. If the current is supplied from a source > 25 V, series resistance of $\geq (V - 25)/0.0215$ Ω is needed, where V is the source voltage. The maximum value of the resistance is $(V - 5)/0.0215$ Ω .
Fault indication output		
Connection		SL1: 6b
Output type		open collector transistor (internal fault bus)
Transfer characteristics		
Deviation		
After calibration		Pt100: $\pm (0.06$ % of measurement value in K + 0.1 % of span + 0.1 K (4-wire connection)) thermocouple: $\pm (0.05$ % of measurement value in $^{\circ}$ C + 0.1 % of span + 1 K (1.2 K for types R and S)) , includes ± 0.8 K fault of the cold junction compensation (CJC) mV: $\pm (50$ μ V + 0.1 % of span) potentiometer: $\pm (0.05$ % of full scale + 0.1 % of span, (excludes faults due to lead resistance))
Influence of ambient temperature		Pt100: $\pm (0.0015$ % of measurement value in K + 0.006 % of span)/K $\Delta T_{amb}^{1)}$ thermocouple: $\pm (0.02$ K + 0.005 % of measurement value in $^{\circ}$ C + 0.006 % of span)/K $\Delta T_{amb}^{1)}$, influence of cold junction compensation (CJC) included mV: $\pm (0.01$ % of measurement value + 0.006 % of span)/K $\Delta T_{amb}^{1)}$ potentiometer: ± 0.006 % of span/K $\Delta T_{amb}^{1)}$ ¹⁾ ΔT_{amb} = ambient temperature change referenced to 23 $^{\circ}$ C (296 K)
Influence of supply voltage		< 0.01 % of span
Influence of load		≤ 0.001 % of output value per 100 Ω
Reaction time		worst case value (sensor breakage and/or sensor short circuit detection enabled) mV: 1 s, thermocouples with CJC: 1.1 s, thermocouples with fixed reference temperature: 1.1 s, 3- or 4-wire RTD: 920 ms, 2-wire RTD: 800 ms, Potentiometer: 2.05 s

Technical Data

Galvanic isolation		
Output/supply, programming input		functional insulation, rated insulation voltage 50 V AC There is no electrical isolation between the programming input and the supply. The programming cable provides galvanic isolation so that ground loops are avoided.
Indicators/settings		
Display elements		LEDs
Control elements		DIP switch
Configuration		via DIP switches via PACTware
Labeling		space for labeling at the front
Directive conformity		
Electromagnetic compatibility		
Directive 2014/30/EU		EN 61326-1:2013 (industrial locations)
Conformity		
Electromagnetic compatibility		
		NE 21:2012 EN 61326-3-2:2008
Degree of protection		IEC 60529:2001
Protection against electrical shock		UL 61010-1:2012
Ambient conditions		
Ambient temperature		-20 ... 70 °C (-4 ... 158 °F)
Relative humidity		5 ... 90 %, non-condensing up to 35 °C (95 °F)
Mechanical specifications		
Degree of protection		IP20
Mass		approx. 100 g
Dimensions		12.5 x 106 x 128 mm (0.5 x 4.2 x 5.1 inch) (W x H x D)
Mounting		on termination board
Coding		pin 1, 2 and 4 trimmed For further information see system description.
Data for application in connection with hazardous areas		
EU-type examination certificate		
		BASEEFA 14 ATEX 0129 X
Marking		⊕ II (1)G [Ex ia Ga] IIC ⊕ II (1)D [Ex ia Da] IIIC ⊕ I (M1) [Ex ia Ma] I
Input		[Ex ia Ga] IIC, [Ex ia Da] IIIC, [Ex ia Ma] I
Voltage	U _o	9 V
Current	I _o	13.1 mA
Power	P _o	30 mW
Analog outputs, power supply, collective error		
Maximum safe voltage	U _m	250 V (Attention! This is not the rated voltage.)
Interface		
Maximum safe voltage	U _m	250 V (Attention! The rated voltage is lower.), RS 232
Certificate		
Marking		⊕ II 3G Ex nA IIC T4 Gc
Galvanic isolation		
Input/Other circuits		safe electrical isolation acc. to IEC/EN 60079-11, voltage peak value 375 V
Directive conformity		
Directive 2014/34/EU		EN IEC 60079-0:2018+AC:2020 , EN 60079-11:2012 , EN 60079-15:2010
International approvals		
FM approval		
Control drawing		116-0429 (cFMus)
UL approval		
Control drawing		116-0391 (cULus)
IECEX approval		
IECEX certificate		IECEX BAS 14.0071X IECEX BAS 16.0003X

Technical Data

IECEX marking	[Ex ia Ga] IIC , [Ex ia Da] IIIC , [Ex ia Ma] I Ex nA IIC T4 Gc
General information	
Supplementary information	Observe the certificates, declarations of conformity, instruction manuals, and manuals where applicable. For information see www.pepperl-fuchs.com .

Assembly

Front view

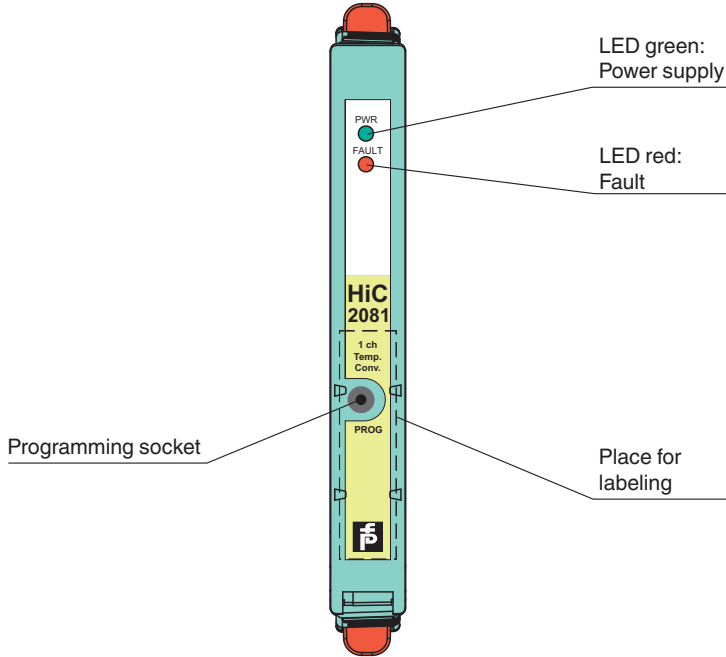

Configuration

- Configure the device in the following way:
- Push the red Quick Lok Bars on each side of the device in the upper position.
 - Remove the device from termination board.
 - Set the switches according to the figure in the **Configuration** section.

Note

The pins for this device are trimmed to polarize it according to its safety parameters. Do not change the setting. For further information see system description.

Matching System Components

	DTM Interface Technology	Device type manager (DTM) for interface technology
	PACTware 5.0	FDT Framework
	K-ADP-USB	Programming adapter with USB interface

Accessories

	H-CJC-Pt100	Resistance thermometer for cold junction compensation for H-System termination boards
--	--------------------	---

Release date: 2023-06-05 Date of issue: 2023-06-05 Filename: 70159064_eng.pdf

Configuration

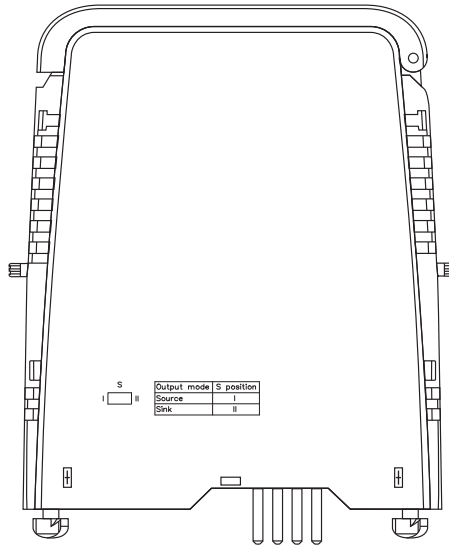

Switch position

Output mode	Switch position
Source	I
Sink	II