

# Absolute rotary encoder

## ENA58IL-R15YY5-1212SG1-RBY:01

- SSI interface
- Recessed hollow shaft
- Resolution: 12 singleturn, 12 bit multiturn
- Free of wear magnetic sampling
- High resolution and accuracy



### Function

The ENA58IL series are high precision encoders with internal magnetic sampling. This multiturn absolute encoder transmits a position value corresponding to the shaft setting via the SSI interface (Synchronous Serial Interface). The control module sends a start sequence to the absolute encoder to obtain the position data. The rotary encoder then sends the position data synchronous to the cycles of the control module.

### Dimensions

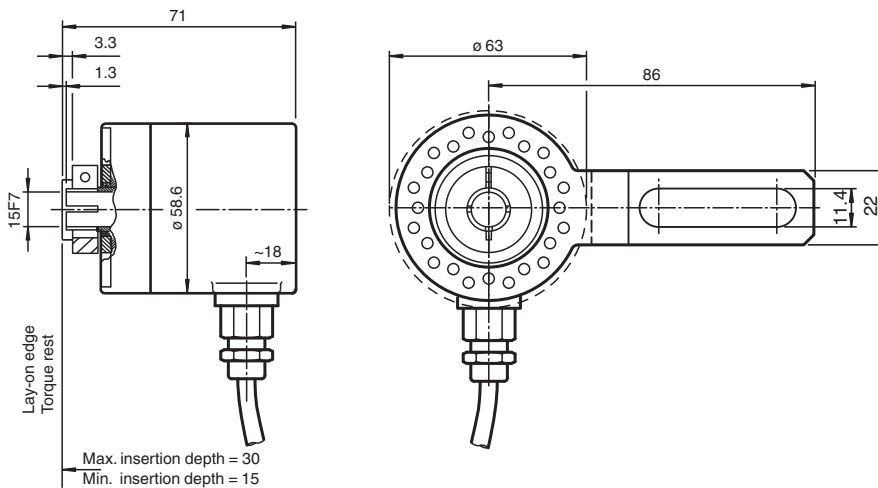

### Technical Data

#### General specifications

Detection type	magnetic sampling	
Device type	Absolute rotary encoder	
Linearity error	$\leq \pm 0.1^\circ$	
UL File Number	E223176 "For use in NFPA 79 Applications only", if UL marking is marked on the product.	

#### Electrical specifications

Operating voltage	$U_B$	4.5 ... 30 V
No-load supply current	$I_0$	typ. 50 mA
Power consumption	$P_0$	approx. 1.5 W
Time delay before availability	$t_v$	< 450 ms
Output code	Gray code	
Code course (counting direction)	cw ascending	

#### Interface

Interface type	SSI	
Resolution		

## Technical Data

Single turn	12 Bit
Multiturn	12 Bit
Transfer rate	0.1 ... 2 MBit/s
Cycle time	< 100 µs
Standard conformity	RS 422
<b>Connection</b>	
Fixed cable with plug	cable Ø8 mm, 8 x 2 x 0.14 mm <sup>2</sup> , length 300 mm, M12 connector, 8-pin
<b>Standard conformity</b>	
Degree of protection	DIN EN 60529, IP65
Climatic testing	DIN EN 60068-2-3, no moisture condensation
Emitted interference	EN 61000-6-4:2007
Noise immunity	EN 61000-6-2:2005
Shock resistance	DIN EN 60068-2-27, 200 g, 6 ms
Vibration resistance	DIN EN 60068-2-6, 20 g, 10 ... 1000 Hz
<b>Approvals and certificates</b>	
UL approval	cULus Listed, General Purpose, Class 2 Power Source, if UL marking is marked on the product.
<b>Ambient conditions</b>	
Operating temperature	cable, flexing: -5 ... 70 °C (23 ... 158 °F)
Storage temperature	-40 ... 85 °C (-40 ... 185 °F)
Relative humidity	98 % , no moisture condensation
<b>Mechanical specifications</b>	
Material	
Housing	nickel-plated steel, painted
Flange	Aluminum
Shaft	Stainless steel
Mass	approx. 300 g
Rotational speed	max. 12000 min <sup>-1</sup>
Moment of inertia	50 gcm <sup>2</sup>
Starting torque	< 5 Ncm
Shaft load	
Axial	24 N
Radial	198 N
Angle offset	± 0.9 °
Axial offset	± 0.3 mm static
Radial offset	± 0.5 mm static
<b>General information</b>	
Scope of delivery	Spring plate is enclosed as accessory

## Connection

Signal	Connector M12, 8-pin
Not connected	1
+U <sub>B</sub> (rotary encoder)	2
Data (+)	3
Data (-)	4
Clock (+)	5
Clock (-)	6
GND (rotary encoder)	7
Not connected	8

## Connection Assignment

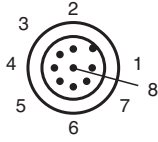

**Interface**

The Synchronous Serial Interface was specially developed for transferring the output data of an absolute encoder to a control device. The control module sends a clock bundle and the absolute encoder responds with the position value. Thus only 4 lines are required for the clock and data, no matter what the resolution of the rotary encoder is. The RS 422 interface is optically isolated from the power supply.

**SSI signal course Standard**

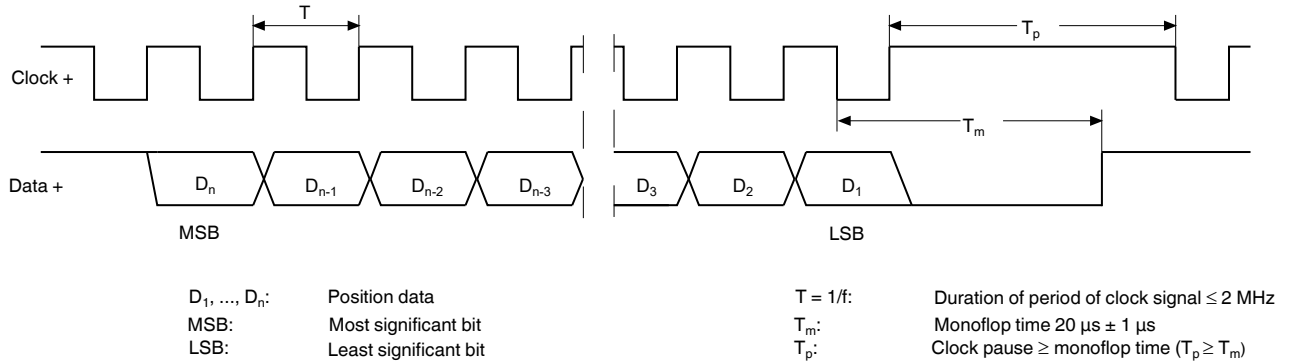

**SSI output format Standard**

- At idle status signal lines "Data +" and "Clock +" are at high level (5 V).
- The first time the clock signal switches from high to low, the data transfer in which the current information (position data ( $D_n$ )) is stored in the encoder is introduced.
- The highest order bit (MSB) is applied to the serial data output of the encoder with the first rising pulse edge.
- The next successive lower order bit is transferred with each following rising pulse edge.
- After the lowest order bit (LSB) has been transferred the data line switches to low until the monoflop time  $T_m$  has expired.
- No subsequent data transfer can be started until the data line switches to high again or the time for the clock pause  $T_p$  has expired.
- After the clock sequence is complete, the monoflop time  $T_m$  is triggered with the last falling pulse edge.
- The monoflop time  $T_m$  determines the lowest transmission frequency.

**SSI output format ring slide operation (multiple transmission)**

- In ring slide operation, multiple transmission of the same data word over the SSI interface makes it possible to offer the possibility of detecting transmission errors.
- In multiple transmission, n bits are transferred per data word in standard format. The value n equals the total resolution of the encoder.  
 As an example: a multiturn encoder with a resolution of 8192 steps/revolution (13 bit) and a max. number of 4096 revolutions (12 bit) has a total resolution of  $n = 25$  bit.
- If the clock change is not interrupted after the last falling pulse edge, ring slide operation automatically becomes active. This means that the information that was stored at the time of the first clock change is generated again.
- After the first position transmission, the n+1 pulse controls data repetition. If the n+1 pulse follows after an amount of time greater than the monoflop time  $T_m$ , a new current data word will be transmitted with the following pulses.



If the pulse line is exchanged, the data word is generated offset.

**Block diagram**

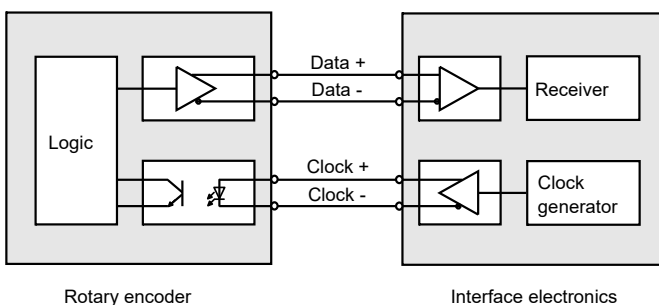

**Line length**

Line length in m	Baudrate in kHz
< 50	< 400
< 100	< 300
< 200	< 200
< 400	< 100

Release date: 2023-05-05 Date of issue: 2023-05-05 Filename: 70161915\_eng.pdf