



SMART Transmitter Power Supply/SMART Current Driver

KCD2-SCS-Ex2

- 2-channel isolated barrier
- 24 V DC supply (Power Rail)
- Analog input (AI), Analog output (AO)
- Operates as transmitter power supply or current driver
- Housing width 12.5 mm
- Up to SIL 2 (SC 3) acc. to IEC/EN 61508



Function

This isolated barrier is used for intrinsic safety applications. Each device channel works as a transmitter power supply or a current driver. The device transfers data by using a current signal. The device supports a bi-directional communication for SMART devices that use current modulation to transmit data and voltage modulation to receive data. For current driver operation, an open field circuit presents a high impedance to the control side to allow lead breakage to be monitored by control systems.

Connection

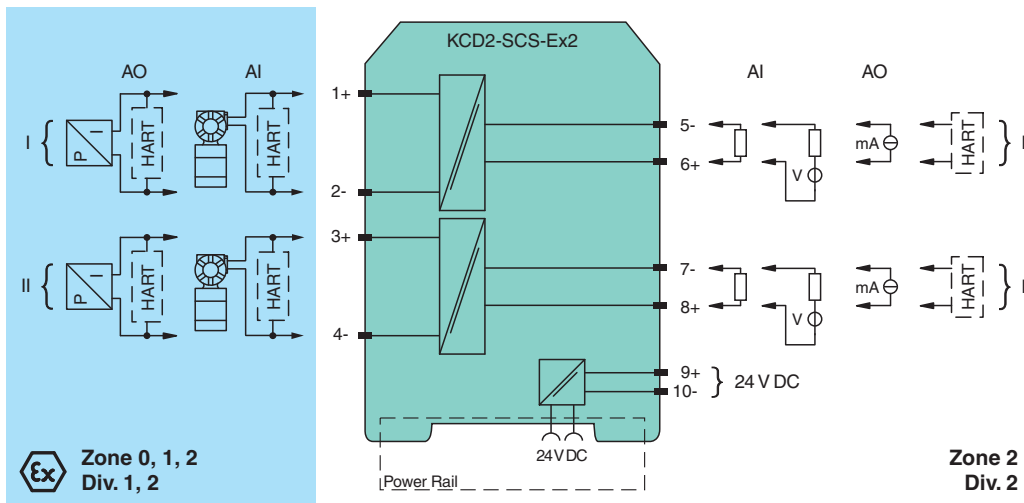

Technical Data

General specifications	
Signal type	Analog input/analog output
Functional safety related parameters	
Safety Integrity Level (SIL)	SIL 2
Systematic capability (SC)	SC 3
Supply	
Connection	Power Rail or terminals 9+, 10-
Rated voltage	U_r 19 ... 30 V DC
Ripple	max. 10 %
Rated current	I_r max. 88 mA at 24 V

Release date: 2024-08-26 Date of issue: 2024-08-26 Filename: 70166762_eng.pdf

Technical Data

Power dissipation	max. 1.4 W
Power consumption	max. 2.1 W
Analog input	
Number of channels	2
Suitable field devices	2-wire SMART transmitters
Signal	0/4 ... 20 mA , limited to approx. 30 mA
Field circuit	terminals 1+, 2-, 3+, 4-
Available voltage	min. 15 V at 20 mA min. 18 V at 4 mA
Control circuit	terminals 5-, 6+; 7-, 8+ limited electrical values : max. 30 V , max. 2 A
Input voltage	Voltage across terminals 10 ... 30 V. If the current is supplied from a source > 24 V, series resistance of $\geq (V - 24)/0.02 \Omega$ is needed, where V is the source voltage. The maximum value of the resistance is $(V - 10)/0.02 \Omega$. (sink output)
Load	max. 350 Ω (source output)
Ripple	20 mV _{eff}
Analog output	
Number of channels	2
Suitable field devices	SMART I/P converters (positioner), on-site-displays
Signal	0/4 ... 20 mA , limited to approx. 30 mA
Field circuit	terminals 1+, 2-, 3+, 4-
Load	max. 650 Ω
Voltage	min. 13 V at 20 mA
Ripple	20 mV _{eff} , on all signal terminals
Control circuit	terminals 5-, 6+; 7-, 8+ limited electrical values : max. 30 V , max. 2 A
Voltage drop	max. 6 V
Line fault detection	> 100 k Ω at max. 30 V, with field wiring open
Transfer characteristics	
Deviation	max. 20 μ A incl. calibration, linearity, hysteresis, loads and fluctuations of supply voltage
Influence of ambient temperature	< 2 μ A/K (-40 ... 70 °C (-40 ... 158 °F))
Frequency range	field side into the control side: bandwidth with 0.5 V _{pp} signal 0 ... 3 kHz (-3 dB) control side into the field side: bandwidth with 0.5 V _{pp} signal 0 ... 3 kHz (-3 dB)
Settling time	max. 200 ms
Rise time/fall time	max. 100 ms (10 ... 90 %)
Galvanic isolation	
Field circuit/control circuit	basic insulation according to IEC/EN 61010-1, rated insulation voltage 300 V _{eff}
Control circuit/control circuit	functional isolation, rated voltage: 50 V
Field circuit/power supply	reinforced insulation according to IEC/EN 61010-1, rated insulation voltage 300 V _{eff}
Control/power supply	basic insulation according to IEC/EN 61010-1, rated insulation voltage 300 V _{eff}
Indicators/settings	
Display elements	LED
Factory setting	analog input with source output
Configuration	via DIP switches
Labeling	space for labeling at the front
Directive conformity	
Electromagnetic compatibility	
Directive 2014/30/EU	EN 61326-1:2013 (industrial locations)
Conformity	
Electromagnetic compatibility	NE 21:2017 EN 61326-3-2:2018
Degree of protection	IEC 60529:2001
Protection against electrical shock	UL 61010-1:2019
Ambient conditions	
Ambient temperature	-40 ... 70 °C (-40 ... 158 °F)

Technical Data

Mechanical specifications		
Degree of protection		IP20
Connection		screw terminals
Mass		approx. 115 g
Dimensions		12.5 x 124 x 114 mm (0.5 x 4.9 x 4.5 inch) (W x H x D) , housing type A2
Mounting		on 35 mm DIN mounting rail acc. to EN 60715:2001
Data for application in connection with hazardous areas		
EU-type examination certificate		UL 22 ATEX 2786 X
Marking		⊕ II (1)G [Ex ia Ga] IIC ⊕ II (1)D [Ex ia Da] IIIC ⊕ I (M1) [Ex ia Ma] I
Output		Ex ia, Ex iaD
Voltage	U_o	25.2 V
Current	I_o	100 mA
Power	P_o	630 mW
Internal capacitance	C_i	1.05 nF
Internal inductance	L_i	0
Supply		
Maximum safe voltage	U_m	250 V _{rms} (Attention! The rated voltage can be lower.)
Input		
Maximum safe voltage	U_m	250 V _{rms} (Attention! The rated voltage can be lower.)
Certificate		UL 22 ATEX 2787 X
Marking		⊕ II 3G Ex ec IIC T4 Gc [device in zone 2]
Galvanic isolation		
Field circuit/control circuit		safe electrical isolation acc. to IEC/EN 60079-11, voltage peak value 375 V
Field circuit/power supply		safe electrical isolation acc. to IEC/EN 60079-11, voltage peak value 375 V
Directive conformity		
Directive 2014/34/EU		EN IEC 60079-0:2018 , EN 60079-11:2012 , EN IEC 60079-7:2015+A1:2018
International approvals		
UL approval		E106378
Control drawing		116-0490 (cULus)
IECEX approval		
IECEX certificate		IECEX ULD 22.0020X
IECEX marking		[Ex ia Ga] IIC , [Ex ia Da] IIIC , [Ex ia Ma] I Ex ec IIC T4 Gc
General information		
Supplementary information		Observe the certificates, declarations of conformity, instruction manuals, and manuals where applicable. For information see www.pepperl-fuchs.com .

Release date: 2024-08-26 Date of issue: 2024-08-26 Filename: 70166762_eng.pdf

Assembly

Front view

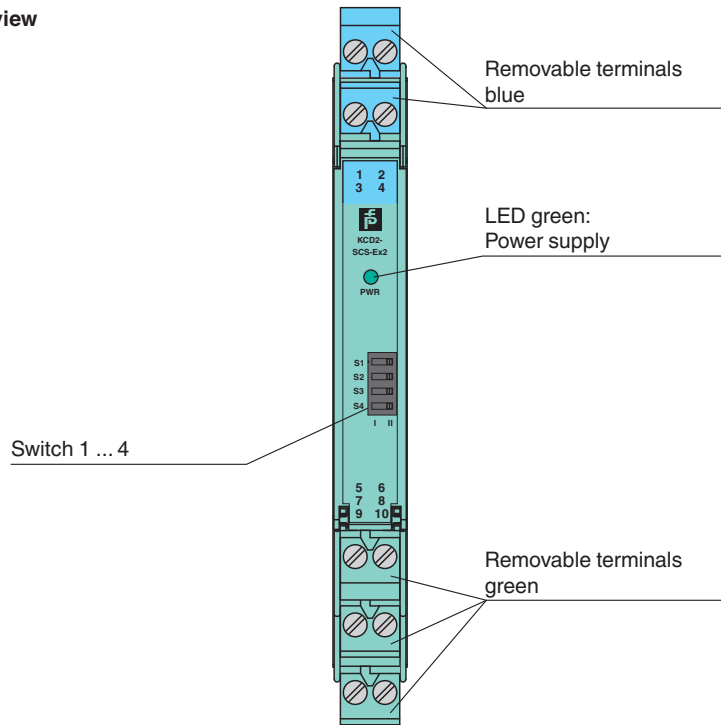

Configuration

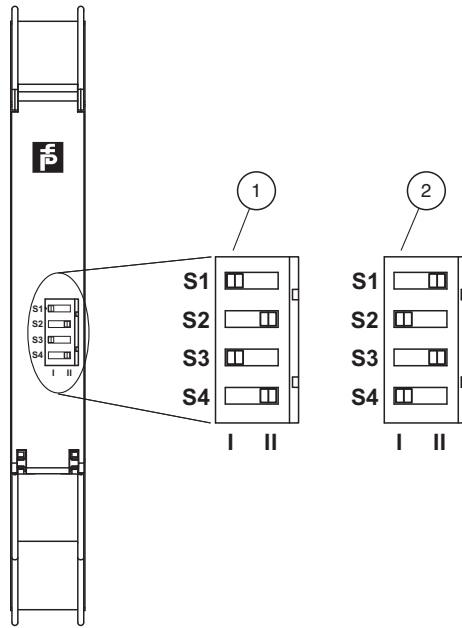

- 1 Analog input with current source output
- 2 Analog input with current sink output, analog output

Switch position

Function		Switch			
		Channel 1		Channel 2	
Field side	Control side	S1	S2	S3	S4
Analog input	Current source	I	II	I	II
Analog input	Current sink	II	I	II	I
Analog output		II	I	II	I

Factory setting: analog input with current source output

Release date: 2024-08-26 Date of issue: 2024-08-26 Filename: 70166762_eng.pdf