

# Universal Input/Output LB7004E

- 4-channel
- Analog input, digital input, analog output, digital output
- Installation in Zone 2 or safe area
- Supply circuit 21.5 V (4 mA)
- HART communication via field bus or service bus
- Simulation mode for service operations (forcing)
- Line fault detection (LFD): one LED per channel
- Permanently self-monitoring
- Output with bus-independent safety shutdown

Universal input/output with HART communication and switch-off input



## Function

The device is a configurable universal module. Each channel can operate in the following modes:

- As an analog input (AI) it feeds 2-wire transmitters.
- As an analog output (AO) it can drive proportional valves, I/P converters, or local indicators.
- As a digital input (DI) it reads dry contacts.
- As a digital output (DO) it can drive solenoids, sounders, or LED.

A combination of analog and digital I/O is possible.

Channel LEDs indicate the status of each channel. White LEDs indicate whether AI, AO, DI, DO are selected. The outputs can be switched off via a contact. This can be used for bus independent safety applications. The signals are galvanically isolated from the bus and the power supply.

## Wiring Diagram

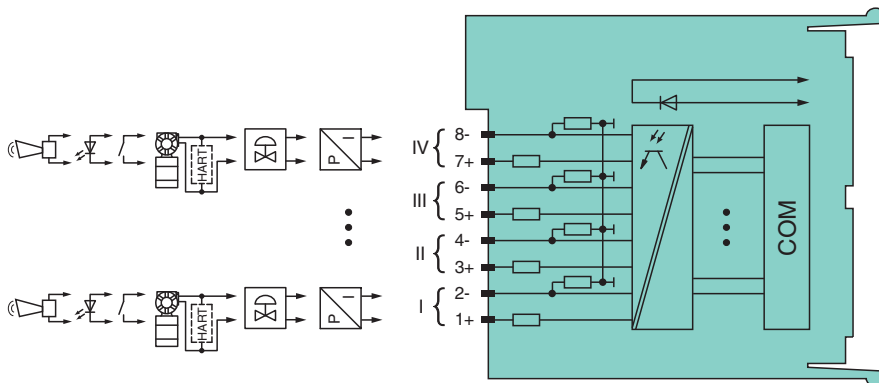

Zone 2

## Technical Data

<b>Slots</b>			
Occupied slots	1		
<b>Functional safety related parameters</b>			
Safety Integrity Level (SIL)	SIL 2		
<b>Supply</b>			
Connection	backplane bus		
Rated voltage	$U_r$	12 V DC , only in connection with the power supplies LB9***	
Power dissipation	2.15 W		
Power consumption	3.3 W		

Release date: 2025-05-23 Date of issue: 2025-05-23 Filename: 70176489\_eng.pdf

**Technical Data**

<b>Internal bus</b>	
Connection	backplane bus
Interface	manufacturer-specific bus to standard com unit
<b>Analog input</b>	
Number of channels	4
Suitable field devices	
Field device	pressure converter
Field device [2]	flow converter
Field device [3]	level converter
Field device [4]	Temperature Converter
Field device interface	
Connection	2-wire transmitter
Connection	terminals 1+, 2-; 3+, 4-; 5+, 6-; 7+, 8-
Transmitter supply voltage	min. 15 V at 20 mA ; 21.5 V at 4 mA
Input resistance	15 Ω
Line fault detection	can be switched on/off for each channel via configuration tool , configurable via configuration tool
Short-circuit	factory setting: > 21 mA Can be parameterized in the range 0 ... 22 mA
Open-circuit	factory setting: < 3.6 mA Can be parameterized in the range 0 ... 22 mA
HART communication	yes
HART secondary variable	yes
<b>Analog output</b>	
Number of channels	4
Suitable field devices	
Field device	Proportional Valve
Field device [2]	I/P converters
Field device [3]	on-site display
Connection	terminals 1+, 2-; 3+, 4-; 5+, 6-; 7+, 8-
Current	0 ... 20 mA short-circuit protected
Line fault detection	can be switched on/off for each channel via configuration tool , configurable via configuration tool
Short-circuit	factory setting: < 50 Ω configurable between 0 ... 26 mA
Open-circuit	deviation of preset output value > 0.5 mA
Load	max. 750 Ω at 20 mA
HART communication	yes
HART secondary variable	yes
Watchdog	output off 0.5 s after serious fault
<b>Digital input</b>	
Number of channels	4
Sensor interface	
Connection [2]	volt-free contact
Connection	terminals 1+, 2-; 3+, 4-; 5+, 6-; 7+, 8-
Line fault detection	can be switched on/off for each channel via configuration tool
Connection	mechanical switch with additional resistors (see connection diagram)
Short-circuit	> 7 mA
Open-circuit	< 0.1 mA
Digital signals (active)	
Switching point: ON	> 2.1 mA
Switching point: OFF	< 1.2 mA
<b>Digital output</b>	
Number of channels	4
Suitable field devices	
Field device	Solenoid Valve
Field device [2]	audible alarm

Release date: 2025-05-23 Date of issue: 2025-05-23 Filename: 70176489\_eng.pdf

**Technical Data**

Field device [3]		visual alarm
Connection		terminals 1+, 2-, 3+, 4-, 5+, 6-, 7+, 8-
Drive capability		12 V / 22 mA
Internal resistor	$R_i$	385 $\Omega$
Current limit	$I_{max}$	22 mA
Open loop voltage	$U_s$	min. 22.7 V
Line fault detection		can be switched on/off for each channel via configuration tool
Test current		0.4 mA
Short-circuit		< 50 $\Omega$
Open-circuit		< 0.2 mA
<b>Transfer characteristics</b>		
Deviation		
After calibration		0.1 % of the signal range at 20 °C (68 °F)
Influence of ambient temperature		0.01 %/K of the signal range
Refresh time		approx. 100 ms (4 channels)
<b>Indicators/settings</b>		
LED indication		Power LED (P) green: supply Diagnostic LED (I) red: module fault , red flashing: communication error , white: fixed parameter set (parameters from com unit are ignored) , white flashing: requests parameters from com unit Status LED (1-4) red: line fault (lead breakage or short circuit) , yellow: state of digital I/O (0/1) Configuration LED (AI, AO, DI, DO) white: selected channel mode
Coding		optional mechanical coding via front socket
<b>Directive conformity</b>		
Electromagnetic compatibility		
Directive 2014/30/EU		EN 61326-1:2013
<b>Conformity</b>		
Electromagnetic compatibility		NE 21:2007
Degree of protection		IEC 60529:2000
Environmental test		EN 60068-2-14:2009
Shock resistance		EN 60068-2-27:2009
Vibration resistance		EN 60068-2-6:2008
Damaging gas		EN 60068-2-42:2003
Relative humidity		EN 60068-2-78:2001
<b>Ambient conditions</b>		
Ambient temperature		-40 ... 60 °C (-40 ... 140 °F) , 70 °C (non-Ex)
Storage temperature		-40 ... 85 °C (-40 ... 185 °F)
Relative humidity		95 % non-condensing
Altitude		max. 2000 m
Shock resistance		shock type I, shock duration 11 ms, shock amplitude 15 g, number of shocks 18
Vibration resistance		frequency range 10 ... 150 Hz; transition frequency: 57.56 Hz, amplitude/acceleration $\pm 0.075$ mm/1 g; 10 cycles frequency range 5 ... 100 Hz; transition frequency: 13.2 Hz amplitude/acceleration $\pm 1$ mm/0.7 g; 90 minutes at each resonance
Damaging gas		designed for operation in environmental conditions acc. to ISA-S71.04-1985, severity level G3
<b>Mechanical specifications</b>		
Degree of protection		IP20 (module) , mounted on backplane
Connection		removable front connector with screw flange (accessory) wiring connection via spring terminals (0.14 ... 1.5 mm <sup>2</sup> ) or screw terminals (0.08 ... 1.5 mm <sup>2</sup> )
Mass		approx. 100 g
Dimensions		16 x 100 x 102 mm (0.63 x 3.9 x 4 inch)
Height		100 mm
Width		16 mm
Length		103 mm

Release date: 2025-05-23 Date of issue: 2025-05-23 Filename: 70176489\_eng.pdf

## Technical Data

Data for application in connection with hazardous areas	
Certificate	BVS 12 ATEX E 115 X
Marking	Ⓜ II 3 G Ex nA [ic] IIC T4 Gc
Galvanic isolation	
Rated voltage	$U_m$ 250 V field circuits to control and supply circuits
Input/power supply, internal bus	safe electrical isolation acc. to EN 60079-11, voltage peak value 375 V
Output/power supply, internal bus	safe electrical isolation acc. to EN 60079-11, voltage peak value 375 V
Directive conformity	
Directive 2014/34/EU	EN IEC 60079-0:2018+AC:2020 EN 60079-11:2012 EN 60079-15:2010
International approvals	
ATEX approval	BVS 12 ATEX E 115 X
IECEX approval	
IECEX certificate	IECEX BVS 11.0068X
IECEX marking	Ex nA [ic] IIC T4 Gc
General information	
System information	The module has to be mounted in appropriate backplanes (LB9***) in Zone 2 or outside hazardous areas. Here, observe the corresponding declaration of conformity. For use in hazardous areas (e. g. Zone 2 or Zone 22) the module must be installed in an appropriate enclosure.
Supplementary information	EC-Type Examination Certificate, Statement of Conformity, Declaration of Conformity, Attestation of Conformity and instructions have to be observed where applicable. For information see <a href="http://www.pepperl-fuchs.com">www.pepperl-fuchs.com</a> .

## Assembly

### Front view

