

## Absolute rotary encoder

ENA58IL-S10CA5-0012SY1-RC5:01

- Solid shaft
- SSI interface
- 12 Bit singleturn
- Free of wear magnetic sampling
- High resolution and accuracy



### Function

The ENA58IL series are high precision encoders with internal magnetic sampling. This multiturn absolute encoder transmits a position value corresponding to the shaft setting via the SSI interface (Synchronous Serial Interface). The control module sends a start sequence to the absolute encoder to obtain the position data. The rotary encoder then sends the position data synchronous to the cycles of the control module. It is possible to select the counting direction with the function input.

### Dimensions

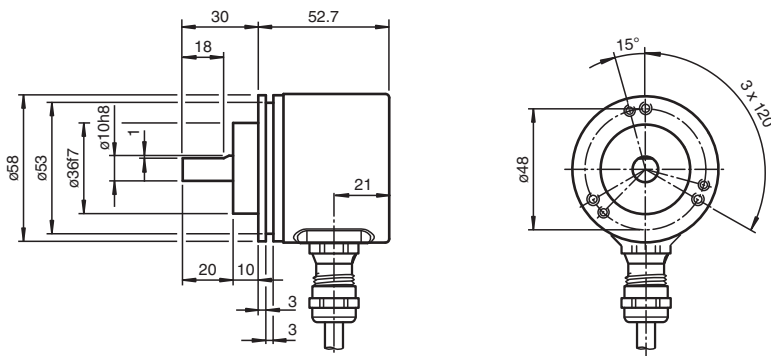

### Technical Data

#### General specifications

Detection type	magnetic sampling	
Device type	Absolute rotary encoder	
Linearity error	$\leq \pm 0.1^\circ$	
UL File Number	E223176 "For use in NFPA 79 Applications only", if UL marking is marked on the product.	

#### Electrical specifications

Operating voltage	$U_B$	4.5 ... 30 V DC
No-load supply current	$I_0$	typ. 50 mA
Power consumption	$P_0$	approx. 1 W
Time delay before availability	$t_v$	< 450 ms
Output code	Gray code	
Code course (counting direction)	adjustable	

Release date: 2024-12-12 Date of issue: 2024-12-12 Filename: 70177706\_eng.pdf

## Technical Data

Interface	
Interface type	SSI
Resolution	
Single turn	12 Bit
Transfer rate	0.1 ... 2 MBit/s
Cycle time	< 100 µs
Input 1	
Input type	Selection of counting direction (cw/ccw)
Signal voltage	
High	4.75 V ... $U_B$ or unconnected (cw descending)
Low	0 ... 2 V (cw ascending)
Input current	< 6 mA
Switch-on delay	< 250 ms
Input 2	
Input type	zero-set (PRESET 1) with falling edge
Signal voltage	
High	4.75 V ... $U_B$
Low	0 ... 2 V
Input current	< 6 mA
Signal duration	min. 1.1 s
Connection	
Cable	Ø7 mm, 6 x 2 x 0.14 mm <sup>2</sup> , 5 m
Standard conformity	
Degree of protection	IP65
Climatic testing	DIN EN 60068-2-3, no moisture condensation
Emitted interference	EN 61000-6-4:2007
Noise immunity	EN 61000-6-2:2005
Shock resistance	DIN EN 60068-2-27, 200 g, 6 ms
Vibration resistance	DIN EN 60068-2-6, 20 g, 10 ... 1000 Hz
Approvals and certificates	
UL approval	cULus Listed, General Purpose, Class 2 Power Source, if UL marking is marked on the product.
Ambient conditions	
Operating temperature	cable, movable installation: -5 ... 70 °C (23 ... 158 °F), cable, fixed installation: -30 ... 70 °C (-22 ... 158 °F)
Storage temperature	-40 ... 85 °C (-40 ... 185 °F)
Relative humidity	98 %, no moisture condensation
Mechanical specifications	
Material	
Housing	nickel-plated steel, painted
Flange	Aluminum
Shaft	Stainless steel
Mass	approx. 300 g, with cable
Rotational speed	max. 12000 min <sup>-1</sup>
Moment of inertia	50 gcm <sup>2</sup>
Starting torque	< 5 Ncm
Shaft load	
Axial	40 N
Radial	110 N

**Connection**

Signal	Cable	Explanation
GND (encoder)	White	Power supply
+U <sub>B</sub> (encoder)	Brown	Power supply
Clock (+)	Green	Positive cycle line
Clock (-)	Yellow	Negative cycle line
Data (+)	Grey	Positive transmission data
Data (-)	Pink	Negative transmission data
V/R	Red	Input for selection of counting direction
PRESET 1	Blue	Zero-setting input

**Interface**

The Synchronous Serial Interface was specially developed for transferring the output data of an absolute encoder to a control device. The control module sends a clock bundle and the absolute encoder responds with the position value. Thus only 4 lines are required for the clock and data, no matter what the resolution of the rotary encoder is. The RS 422 interface is optically isolated from the power supply.

**SSI signal course Standard**

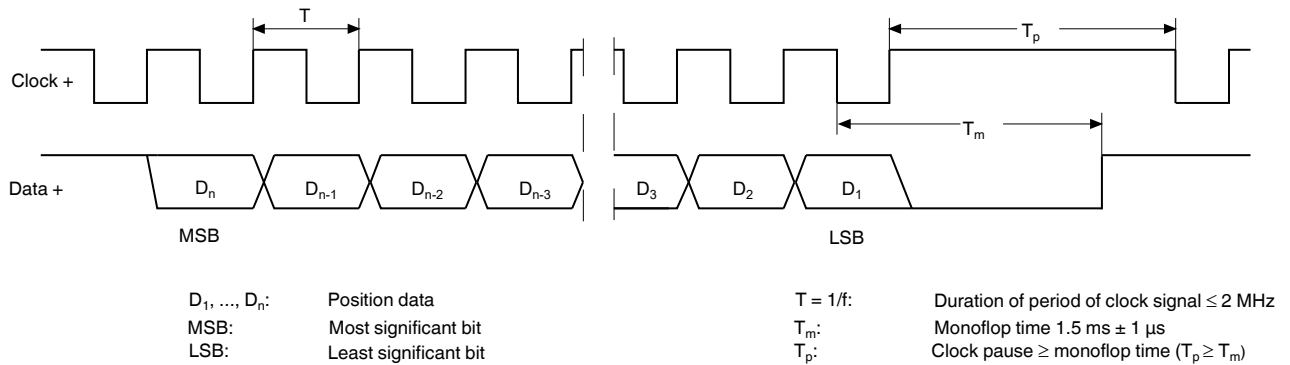

**SSI output format Standard**

- At idle status signal lines "Data +" and "Clock +" are at high level (5 V).
- The first time the clock signal switches from high to low, the data transfer in which the current information (position data (D<sub>n</sub>)) is stored in the encoder is introduced.
- The highest order bit (MSB) is applied to the serial data output of the encoder with the first rising pulse edge.
- The next successive lower order bit is transferred with each following rising pulse edge.
- After the lowest order bit (LSB) has been transferred the data line switches to low until the monoflop time T<sub>m</sub> has expired.
- No subsequent data transfer can be started until the data line switches to high again or the time for the clock pause T<sub>p</sub> has expired.
- After the clock sequence is complete, the monoflop time T<sub>m</sub> is triggered with the last falling pulse edge.
- The monoflop time T<sub>m</sub> determines the lowest transmission frequency.

**SSI output format ring slide operation (multiple transmission)**

- In ring slide operation, multiple transmission of the same data word over the SSI interface makes it possible to offer the possibility of detecting transmission errors.
- In multiple transmission, n bits are transferred per data word in standard format. The value n equals the total resolution of the encoder.  
As an example: a multiturn encoder with a resolution of 8192 steps/revolution (13 bit) and a max. number of 4096 revolutions (12 bit) has a total resolution of n = 25 bit.
- If the clock change is not interrupted after the last falling pulse edge, ring slide operation automatically becomes active. This means that the information that was stored at the time of the first clock change is generated again.
- After the first position transmission, the n+1 pulse controls data repetition. If the n+1 pulse follows after an amount of time greater than the monoflop time T<sub>m</sub>, a new current data word will be transmitted with the following pulses.

Release date: 2024-12-12 Date of issue: 2024-12-12 Filename: 70177706\_eng.pdf



If the pulse line is exchanged, the data word is generated offset.

**Block diagram**

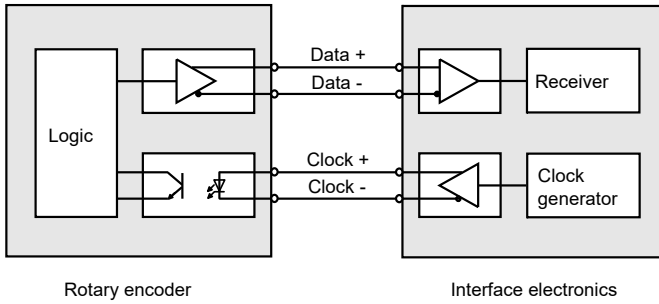

**Line length**

Line length in m	Baudrate in kHz
< 50	< 400
< 100	< 300
< 200	< 200
< 400	< 100