

Retroreflective sensor

RLK39-54-5594/31/40a/116

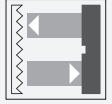

- Glare protected with polarization filter
- Visible red light
- Light-on/dark-on, switchable
- Degree of protection IP54

Retroreflective sensor for standard applications, polarization filter, detection range 7 m, red light, sensitivity adjuster, light/dark on, relay contact output, terminal compartment



Dimensions

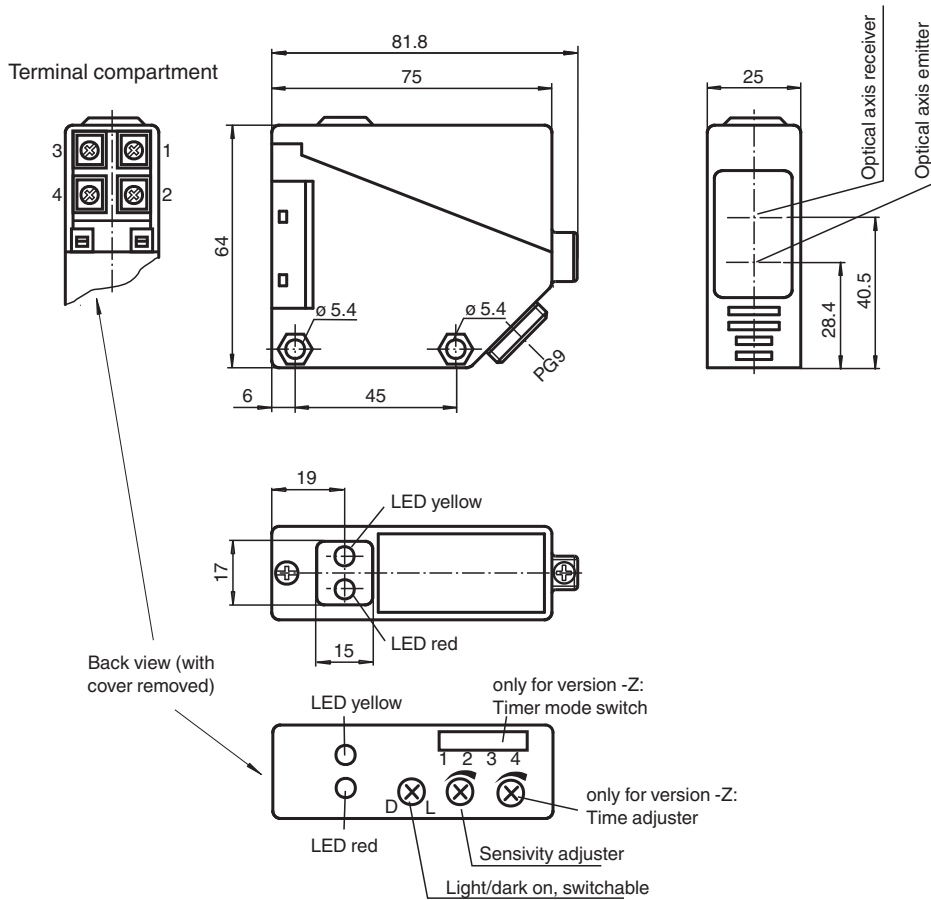

Release date: 2024-03-28 Date of issue: 2024-03-28 Filename: 812306_eng.pdf

Technical Data

General specifications		
Effective detection range		0 ... 5 m
Reflector distance		0.1 ... 5 m
Threshold detection range		6 m
Reference target		H50 reflector
Light source		LED red
Light type		modulated visible red light
Polarization filter		yes
Ambient light limit		IEC / EN 60947-5-2 , 10000 Lux
Functional safety related parameters		
MTTF _d		803 a
Mission Time (T _M)		20 a
Diagnostic Coverage (DC)		0 %
Indicators/operating means		
Function indicator		LED yellow: switching state LED red: pre-fault indication
Control elements		Sensing range adjuster, light-on/dark-on changeover switch
Electrical specifications		
Operating voltage	U _B	12 ... 240 V DC 24 ... 240 V AC (50 ... 60 Hz)
Ripple		10 %
No-load supply current	I ₀	≤ 50 mA
Protection class		II, rated voltage ≤ 250 V AC with pollution degree 1-2 according to IEC 60664-1 Caution! The protection class 2 is only valid when the terminal compartment is closed. output circuit has basic insulation to control circuit according to IEC/EN 61140
Power consumption	P ₀	≤ 3 VA
Time delay before availability	t _v	≤ 300 ms
Output		
Switching type		light/dark on
Signal output		1 relay output
Switching voltage		max. 240 V AC ; 150 V DC
Switching current		max. 3 A
Switching power		DC: max. 90 W AC: max. 750 VA
Switching frequency	f	≤ 25 Hz
Response time		≤ 20 ms
Conformity		
Product standard		EN 60947-5-2
Approvals and certificates		
CCC approval		Certified by China Compulsory Certification (CCC)
Approvals		CE
Ambient conditions		
Ambient temperature		-25 ... 55 °C (-13 ... 131 °F)
Storage temperature		-40 ... 70 °C (-40 ... 158 °F)
Mechanical specifications		
Degree of protection		IP54
Connection		terminal compartment PG9 , ≤ 0.75 mm ²
Material		
Housing		PBT
Optical face		PMMA
Mass		approx. 110 g
Dimensions		
Height		64 mm
Width		25 mm
Depth		75 mm

Connection Assignment

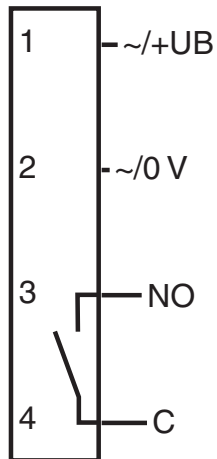

Installation

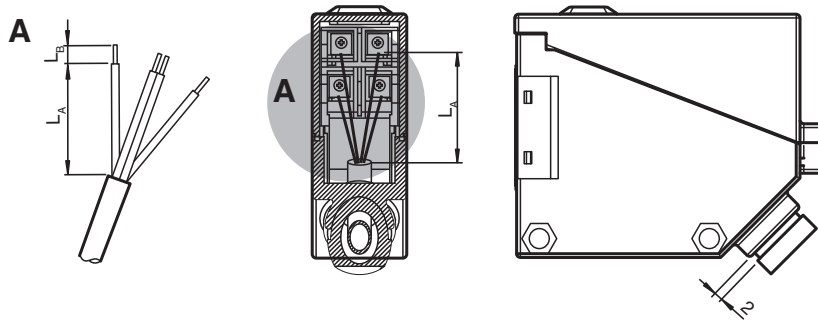

Wire length L_A [mm]	Strip length L_B [mm]
30±2	5±1

Recommendations for cable installation:

1. Use flexible cable with a bending radius less than 5 x outer diameter.
2. Use cable with an outer diameter of 6.2 ± 0.2 mm with the provided gasket with an inner diameter of 7 mm.
3. Cut, strip, and crimp the cable according to the dimensions in the table above.
4. Ensure that the distance between cable gland and housing is approximately 2 mm. Do not screw in the cable gland fully.

Characteristic Curve

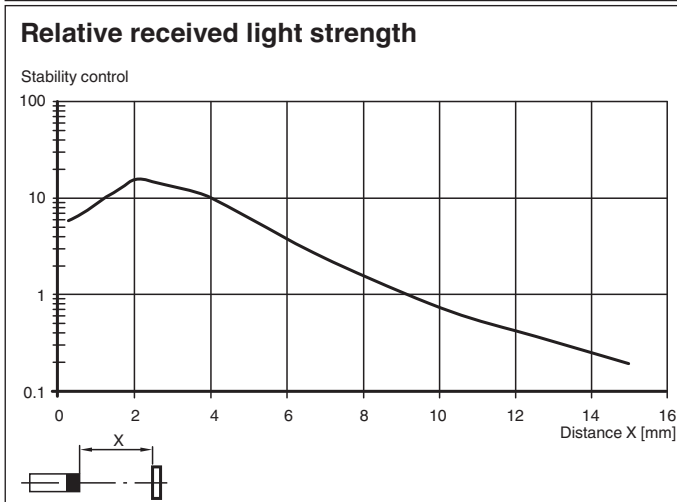
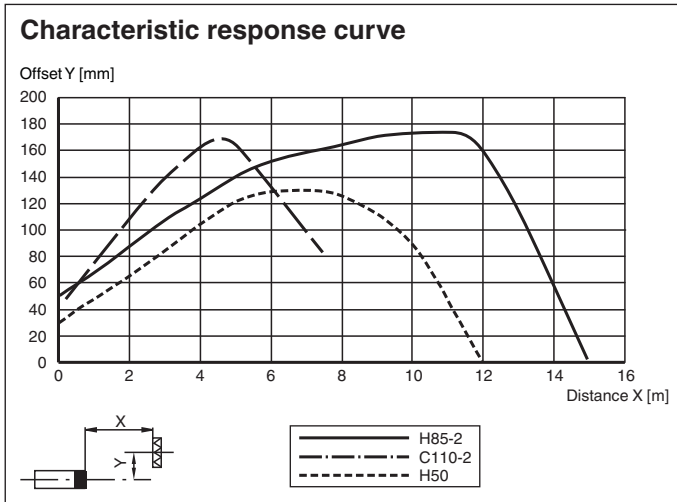

Commissioning

System Description

A retroreflective sensor contains emitters and receivers integrated in a single housing. The emitted light is reflected back to the receiver by a reflector. When the light beam is interrupted by an object, the switching function is triggered.

Mounting

The sensors can be mounted directly via thru-holes.

Ensure that the background is level to prevent the housing from becoming distorted when the fittings are tightened.

Secure the nuts and screws with spring disks to prevent the sensor from becoming misaligned.

Mount a suitable reflector opposite the light barrier. Roughly align the sensor (without an object) with the reflector. Next, adjust the sensor to the reflector by swiveling the sensor horizontally and vertically so that the yellow signal indicator lights up continuously. In the event of misalignment, the red signal indicator lights up.

Commissioning

Checking object detection: Follow the steps below to check that the sensor detects objects as required.

Position the object in the beam path of the sensor.

When the object is detected, the yellow signal indicator goes out. If the yellow signal indicator remains lit, reduce the sensitivity of the potentiometer until the yellow signal indicator goes out.

When the object disappears from the beam path of the sensor, the yellow signal indicator lights up again continuously.

Maintenance

Cleaning: If the transmission reception deteriorates, e.g., due to dirt or misalignment, and is lower than the functional reserve, the red signal indicator on the receiver lights up. Clean the optical interfaces of the sensor (e.g., lenses) at regular intervals.

Maintenance: Check the mounting fittings and the electrical connections regularly.

Release date: 2024-03-28 Date of issue: 2024-03-28 Filename: 812306_eng.pdf