



Inductive sensor NCB40-FP-A2-P2

- 4-wire DC
- Sensing range 40 mm



Dimensions

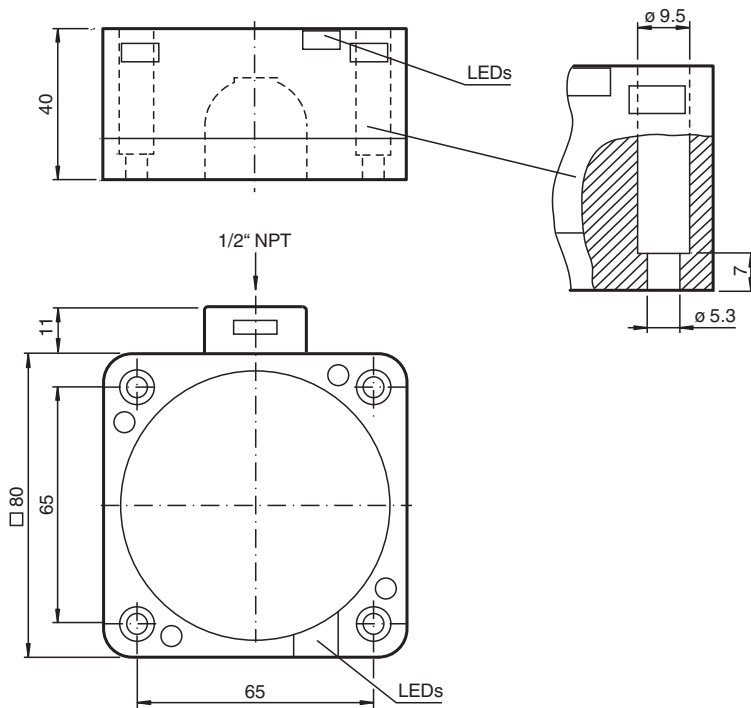

Technical Data

General specifications

Switching function		complementary
Output type		PNP
Rated operating distance	s_n	40 mm
Installation		flush
Output polarity		DC
Assured operating distance	s_a	0 ... 32.4 mm
Reduction factor r_{Al}		0.25
Reduction factor r_{Cu}		0.23
Reduction factor r_{304}		0.85

Release date: 2025-06-05 Date of issue: 2025-06-05 Filename: 908485_eng.pdf

Technical Data

Output type		4-wire
Nominal ratings		
Operating voltage	U_B	10 ... 60 V DC
Switching frequency	f	0 ... 80 Hz
Hysteresis	H	typ. 3 %
Reverse polarity protection		reverse polarity protected
Short-circuit protection		pulsing
Voltage drop	U_d	≤ 3 V
Operating current	I_L	0 ... 200 mA
Off-state current	I_r	0 ... 0.5 mA
No-load supply current	I_0	≤ 20 mA
Time delay before availability	t_v	≤ 300 ms
Operating voltage indicator		LED, green
Switching state indicator		LED, yellow
Functional safety related parameters		
MTTF _d		680 a
Mission Time (T_M)		20 a
Diagnostic Coverage (DC)		0 %
Compliance with standards and directives		
Standard conformity		
Standards		EN IEC 60947-5-2
Approvals and certificates		
UL approval		cULus Listed, General Purpose
CCC approval		Certified by China Compulsory Certification (CCC)
Ambient conditions		
Ambient temperature		-25 ... 70 °C (-13 ... 158 °F)
Mechanical specifications		
Connection type		screw terminals
Core cross section		up to 2.5 mm ²
Housing material		PBT
Sensing face		PBT
Housing base		PBT
Degree of protection		IP68
Dimensions		
Height		40 mm
Width		80 mm
Length		80 mm

Connection

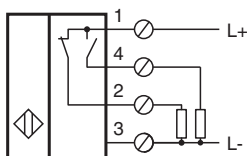

Installation Conditions

These sensors are especially designed for embeddable mounting in conveyor floors. Due to its precise location in metal base plates the sensor is afforded a high degree of mechanical protection. No clearance is required between the sensor and the base plate, avoiding the need for protective guarding to prevent possible foot injury.

The large sensing range ensures positive detection, and thus provides consistent control and monitoring of the conveyor.

