

Multiturn absolute rotary encoder

AHM58-0

- Industrial standard housing Ø58 mm
- 30 Bit multiturn
- Data transfer up to 2 MBaud
- Optically isolated RS 422 interface
- Zero-set function
- Hollow shaft
- Up to 4096 pulses on incremental track



Function

This multiturn absolute encoder with modern fast technology transmits a position value corresponding to the shaft setting via the SSI interface (Synchronous Serial Interface). The maximum resolution of the AHM58 is maximum 65536 steps per revolution at 16384 revolutions. The devices of the AHM58 series are equipped with a microcontroller. The control module sends a clock bundle to the absolute encoder to obtain position data. The rotary encoder then sends the position data synchronous to the cycles of the control module. It is possible to select the following items with function inputs the counting direction and the zero-set function (preset value). The absolute encoder is mounted directly onto the application shaft, without any coupling. Rotation of the absolute encoder is prevented by a torque rest. The electrical connection is made by a 12-pin round plug connector. A version with a 1 m cable connector is also available.

Dimensions

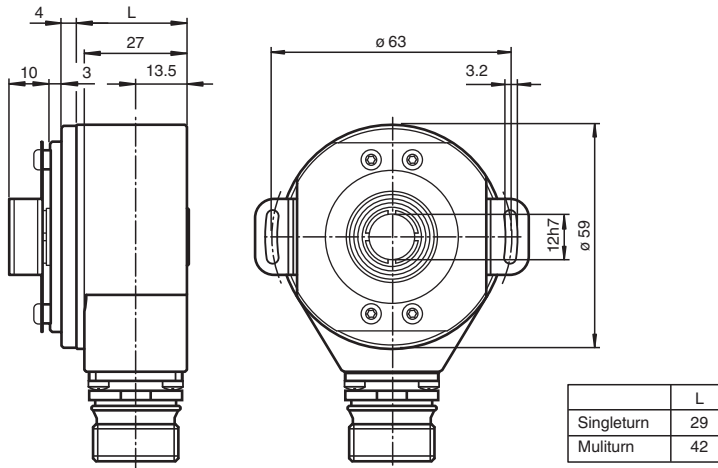

Release date: 2024-09-30 Date of issue: 2024-09-30 Filename: t155421_eng.pdf

Dimensions

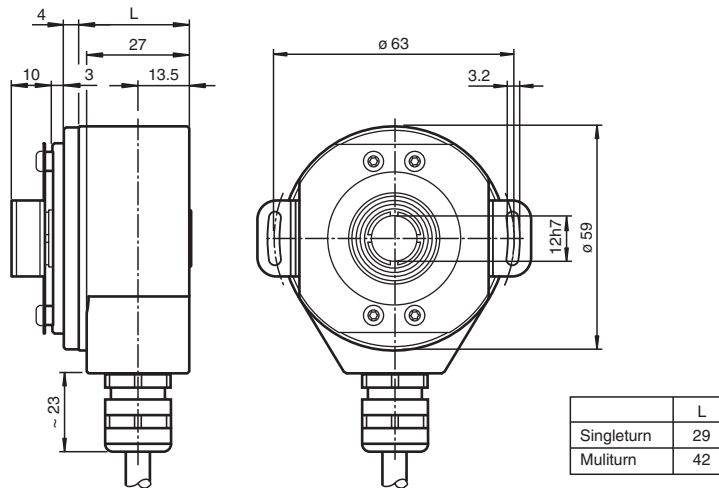

Technical Data

General specifications

Detection type	photoelectric sampling
Device type	Multiturn absolute rotary encoder

Electrical specifications

Operating voltage	U_B	4.5 ... 30 V DC (SSI, SSI + RS422) 10 ... 30 V DC (SSI + Push/Pull)
No-load supply current	I_0	max. 180 mA
Time delay before availability	t_v	< 250 ms
Linearity		± 2 LSB at 16 Bit, ± 1 LSB at 13 Bit, $\pm 0,5$ LSB at 12 Bit
Output code		Gray code, binary code
Code course (counting direction)		cw descending (clockwise rotation, code course descending)

Interface

Interface type	SSI ; SSI + incremental track
Monoflop time	$20 \pm 10 \mu s$
Resolution	
Single turn	up to 16 Bit
Multiturn	14 Bit
Overall resolution	up to 30 Bit
Transfer rate	0.1 ... 2 MBit/s
Voltage drop	$U_B - 2.5 V$
Standard conformity	RS 422

Input 1

Input type	Selection of counting direction (cw/ccw)
Signal voltage	
High	4.5 ... 30 V (SSI, SSI + RS422) 10 ... 30 V (SSI + Push/Pull)
Low	0 ... 2 V
Input current	< 6 mA
Switch-on delay	< 10 ms

Input 2

Input type	zero-set (PRESET 1)
Signal voltage	
High	4.5 ... 30 V (SSI, SSI + RS422) 10 ... 30 V (SSI + Push/Pull)
Low	0 ... 2 V
Input current	< 6 mA
Signal duration	min. 100 ms

Technical Data

Switch-on delay	< 10 ms
Output	
Output type	RS422, Push/Pull
Signal output	A+B+/A+/B
Pulses	1024, 2048, 4096
Connection	
Connector	type 9416 (M23), 12-pin, type 9416L (M23), 12-pin
Cable	Ø7 mm, 6 x 2 x 0.14 mm ² , 1 m
Standard conformity	
Degree of protection	DIN EN 60529, IP65
Climatic testing	DIN EN 60068-2-3, no moisture condensation
Emitted interference	EN 61000-6-4:2007
Noise immunity	EN 61000-6-2:2005
Shock resistance	DIN EN 60068-2-27, 100 g, 6 ms
Vibration resistance	DIN EN 60068-2-6, 20 g, 10 ... 2000 Hz
Approvals and certificates	
UL approval	cULus Listed, General Purpose, Class 2 Power Source
Ambient conditions	
Operating temperature	-40 ... 85 °C (-40 ... 185 °F)
Storage temperature	-40 ... 85 °C (-40 ... 185 °F)
Mechanical specifications	
Material	
Housing	Aluminum
Flange	Aluminum
Shaft	Stainless steel
Mass	approx. 300 g (combination 1)
Rotational speed	max. 3000 min ⁻¹
Moment of inertia	30 gcm ²
Starting torque	< 3 Ncm
Shaft load	
Angle offset	± 0.9 °
Axial offset	static: ± 0.3 mm, dynamic: ± 0.1 mm
Radial offset	static: ± 0.5 mm, dynamic: ± 0.2 mm
Dimensions	
Length	49 mm
Diameter	59 mm

Connection

Signal	Cable Ø7 mm, 12-core	Connector 9416, 12-pin	Connector 9416L, 12-pin	Explanation
GND (encoder)	White	1	1	Power supply
U _b (encoder)	Brown	2	8	Power supply
Clock (+)	Green	3	3	Positive cycle line
Clock (-)	Yellow	4	11	Negative cycle line
Data (+)	Grey	5	2	Positive transmission data
Data (-)	Pink	6	10	Negative transmission data
A	Blue	7	12	Incremental track A
V/R	Red	8	5	Input for selection of counting direction
Reserved	Black	9	9	Not wired, reserved
B	Violet	10	4	Incremental track B
\bar{A}	Grey/Pink	11	6	Incremental track \bar{A}
\bar{B}	Red/Blue	12	7	Incremental track \bar{B}

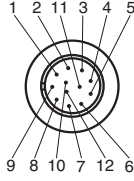
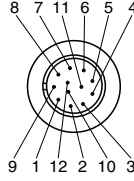
	
---	--

Interface

Description

The Synchronous Serial Interface was specially developed for transferring the output data of an absolute encoder to a control device. The control module sends a clock bundle and the absolute encoder responds with the position value. Thus only 4 lines are required for the clock and data, no matter what the resolution of the rotary encoder is. The RS 422 interface is optically isolated from the power supply.

SSI signal course Standard

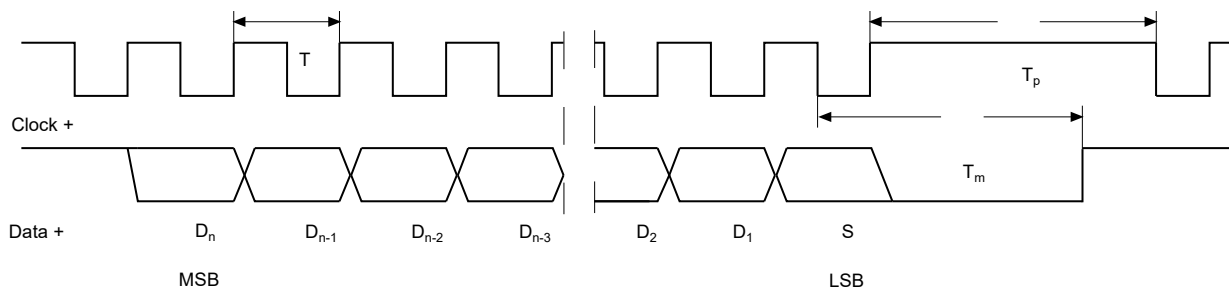

- | | | | |
|--|-----------------------|------------------|--|
| D ₁ , ..., D _n : | Position data | T = 1/f: | Duration of period of clock signal ≤ 1 MHz |
| S: | Special bit | T _m : | Monoflop time 10 μs ... 30 μs |
| MSB: | Most significant bit | T _p : | Clock pause ≥ monoflop time (T _p ≥ T _m) |
| LSB: | Least significant bit | | |

SSI output format Standard

- At idle status signal lines "Data +" and "Clock +" are at high level (5 V).
- The first time the clock signal switches from high to low, the data transfer in which the current information (position data (D_n) and special bit (S)) is stored in the encoder is introduced.
- The highest order bit (MSB) is applied to the serial data output of the encoder with the first rising pulse edge.
- The next successive lower order bit is transferred with each following rising pulse edge.
- After the lowest order bit (LSB) has been transferred the data line switches to low until the monoflop time T_m has expired.
- No subsequent data transfer can be started until the data line switches to high again or the time for the clock pause T_p has expired.
- After the clock sequence is complete, the monoflop time T_m is triggered with the last falling pulse edge.
- The monoflop time T_m determines the lowest transmission frequency.

SSI output format ring slide operation (multiple transmission)

- In ring slide operation, multiple transmission of the same data word over the SSI interface makes it possible to offer the possibility of detecting transmission errors.
- In multiple transmission, 25 bits are transferred per data word in standard format.

Release date: 2024-09-30 Date of issue: 2024-09-30 Filename: t1155421_eng.pdf

- If the clock change is not interrupted after the last falling pulse edge, ring slide operation automatically becomes active. This means that the information that was stored at the time of the first clock change is generated again.
- After the first transmission, the 26th pulse controls data repetition. If the 26th pulse follows after an amount of time greater than the monoflop time T_m , a new current data word will be transmitted with the following pulses.



If the pulse line is exchanged, the data word is generated offset. Ring slide operation is possible up to max. 13 bits.

Block diagram

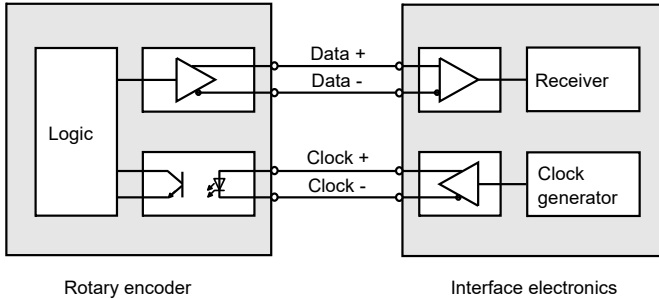

Line length

Line length in m	Baudrate in kHz
< 50	< 400
< 100	< 300
< 200	< 200
< 400	< 100

Inputs

The selection of the counting direction input (cw/ccw) is activated with 0-level. The zero-set input (PRESET 1) is activated with 1-level.

zero-set input (PRESET 1)

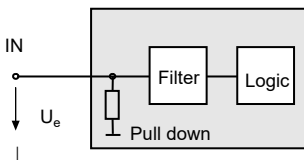

Input for selection of counting direction (cw/ccw)

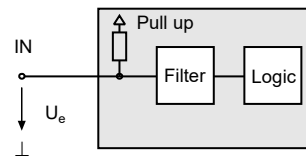

Operation

Signal output

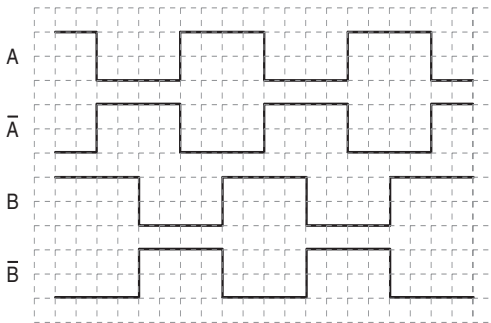

↻ cw - with view onto the shaft

Type Code

Release date: 2024-09-30 Date of issue: 2024-09-30 Filename: t155421_eng.pdf



Number of bits singleturn

- 12** 4096 (standard)
- 13** 8192
- 16** 65536

Number of bits multiturn

- 00** for singleturn-encoders
- 12** 4096 (standard)
- 14** 16384

Options

- N** Standard
- 1** Incremental track 1024 pulses, Push/Pull
- 2** Incremental track 2048 pulses, Push/Pull
- 3** Incremental track 4096 pulses, Push/Pull
- 4** Incremental track 1024 pulses, RS422
- 5** Incremental track 2048 pulses, RS422
- 6** Incremental track 4096 pulses, RS422

Output code

- B** Binary
- G** Gray

Option

- H** Hardware encoder
- 0** Zero set function

Exit position

- R** Radial

Connection type

- K1** Cable Ø7 mm, 6 x 2 x 0.14 mm², 1 m
- AA** Plug connector type 9416, 12-pin
- AB** Plug connector type 9416L, 12-pin

Shaft dimension/flange version

- OAA** Hollow shaft with Ø10 mm
- OBA** Hollow shaft with Ø12 mm

Housing material

- N** Aluminium

Principle of operation

- S** Singleturn
- M** Multiturn

Shaft type

- H** Hollow shaft

Data format

- A** SSI (Synchronous Serial Interface)

Release date: 2024-09-30 Date of issue: 2024-09-30 Filename: t155421_eng.pdf