



# Singleturn absolute rotary encoder

## AVS78E

- Up to 16 Bit singleturn
- ATEX approval
- IECEx approval
- Flameproof enclosure
- Removable connection cap
- Galvanically isolated RS 422 interface



### Function

This absolute rotary encoder returns a position value corresponding to the shaft position via the SSI interface. In order to obtain the position data, the controller sends a start sequence to the absolute rotary encoder. The encoder then responds synchronously to the pulses from the controller with the position data. The modular design enables you to order the absolute rotary encoder so that it fulfills your requirements. A listing of the part options can be found in the ordering information. You can select the counting direction via 2 functional inputs and set the zero position.

### Dimensions

#### Encoder length L

Version		Length L
Radial cable exit	Clamping flange	118 mm
	Servo flange	118 mm
Axial cable exit	Clamping flange	134 mm
	Servo flange	134 mm

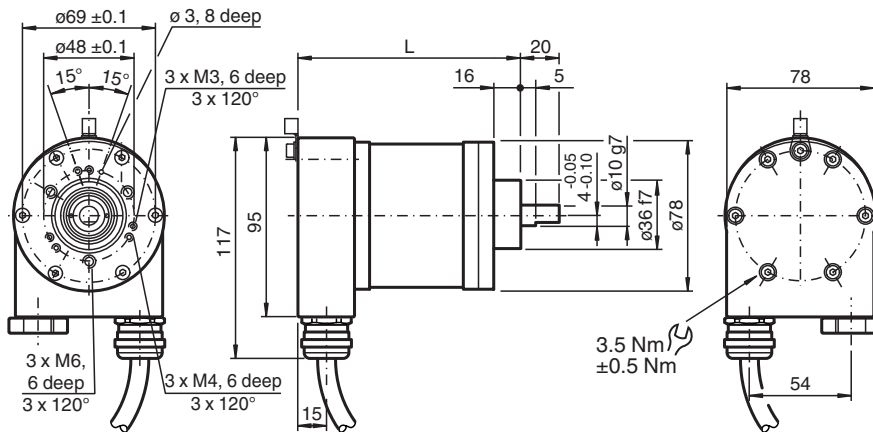

Clamping flange, cable exit radial

Release date: 2024-03-11 Date of issue: 2024-03-11 Filename: t1157828\_eng.pdf

Dimensions

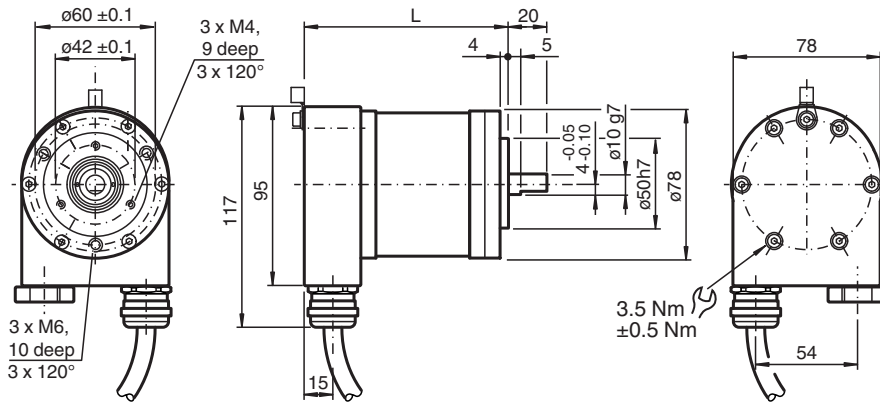

Servo flange, radial cable exit

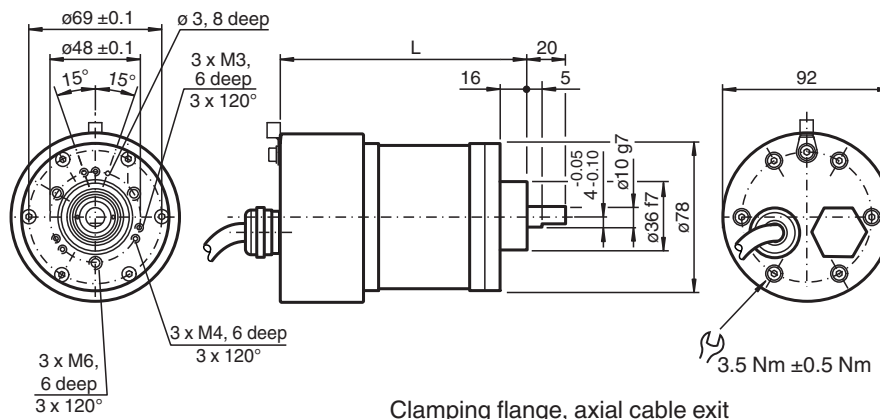

Clamping flange, axial cable exit

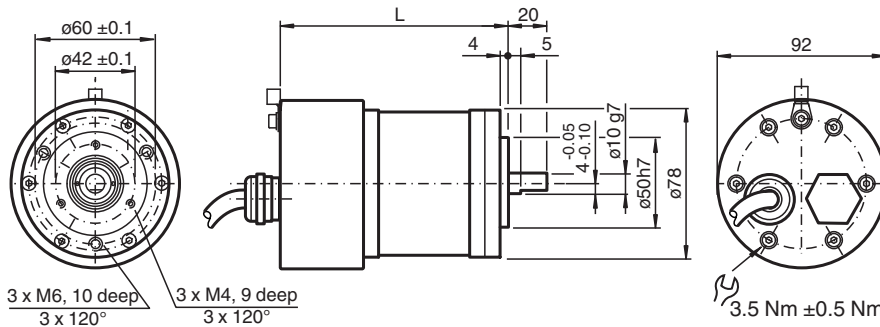

Servo flange, axial cable exit

Shaft 12 mm

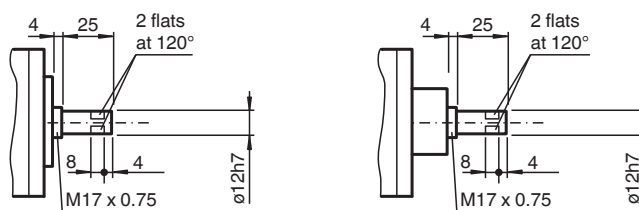

Release date: 2024-03-11 Date of issue: 2024-03-11 Filename: t157828\_eng.pdf

Technical Data

General specifications

## Technical Data

Detection type	photoelectric sampling	
Device type	Singleturn absolute rotary encoder	
<b>Functional safety related parameters</b>		
MTTF <sub>d</sub>	210 a	
L <sub>10</sub>	7.7 E+9 at 3000 rpm	
<b>Electrical specifications</b>		
Operating voltage	U <sub>B</sub>	10 ... 30 V DC
No-load supply current	I <sub>0</sub>	max. 90 mA
Linearity	± 2 LSB at 16 Bit, ± 1 LSB at 13 Bit, ± 0,5 LSB at 12 Bit	
Output code	Gray code, binary code	
Code course (counting direction)	see input 1	
<b>Interface</b>		
Interface type	SSI	
Monoflop time	20 ± 10 µs	
<b>Resolution</b>		
Single turn	up to 16 Bit	
Transfer rate	0.1 ... 2 MBit/s	
Standard conformity	RS 422	
<b>Input 1</b>		
Input type	Selection of counting direction (cw/ccw)	
Signal voltage		
High	10 ... 30 V or open input cw descending (clockwise rotation, code course descending)	
Low	0 ... 2 V cw ascending (clockwise rotation, code course ascending)	
Input current	< 6 mA	
Switch-on delay	< 10 ms	
<b>Input 2</b>		
Input type	zero-set (PRESET)	
Signal voltage		
High	10 ... 30 V	
Low	0 ... 2 V	
Input current	< 6 mA	
Signal duration	min. 100 ms	
Switch-on delay	< 10 ms	
<b>Connection</b>		
Cable	Ø 10.2 mm, Radox 9 x 0.5 mm <sup>2</sup>	
Terminal compartment	see ordering information	
<b>Standard conformity</b>		
Degree of protection	DIN EN 60529, IP66	
Climatic testing	DIN EN 60068-2-78 , no moisture condensation	
Emitted interference	EN 61000-6-4:2007/A1:2011	
Noise immunity	EN 61000-6-2:2005	
Shock resistance	DIN EN 60068-2-27, 100 g, 3 ms	
Vibration resistance	DIN EN 60068-2-6, 10 g, 10 ... 2000 Hz	
<b>Approvals and certificates</b>		
IECEX approval		
Equipment protection level Gb	IECEX ITS 15.0061X	
ATEX approval		
Equipment protection level Gb	ITS 15 ATEX 18372X	
<b>Ambient conditions</b>		
Operating temperature	-40 ... 70 °C (-40 ... 158 °F)	
Storage temperature	-40 ... 85 °C (-40 ... 185 °F)	
<b>Mechanical specifications</b>		

Release date: 2024-03-11 Date of issue: 2024-03-11 Filename: t157828\_eng.pdf

## Technical Data

Material		
Combination 1		housing: anodized aluminum flange: anodized aluminum shaft: Stainless steel 1.4404 / AISI 316L
Combination 2 (Inox)		housing: Stainless steel 1.4404 / AISI 316L flange: Stainless steel 1.4404 / AISI 316L shaft: Stainless steel 1.4404 / AISI 316L
Mass		approx. 2600 g (combination 1) approx. 3900 g (combination 2)
Rotational speed		max. 3000 min <sup>-1</sup>
Moment of inertia		180 gcm <sup>2</sup>
Starting torque		≤ 4 Ncm
Shaft load		
Axial		60 N
Radial		80 N
General information		
Use in the hazardous area		see instruction manuals

**Connection**

Signal	Cable	Terminal compartment
Ground wire	green-yellow	Grounding terminal
GND (rotary encoder)	1	1
+U <sub>b</sub> (rotary encoder)	2	2
Pulse (+)	3	5
Pulse (-)	4	6
Data (+)	5	8
Data (-)	6	7
Preset	7	4
Counting direction	8	3

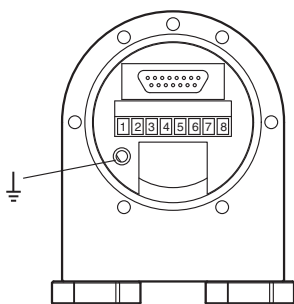

**Interface**

**Description**

The Synchronous Serial Interface was specially developed for transferring the output data of an absolute encoder to a control device. The control module sends a clock bundle and the absolute encoder responds with the position value. Thus only 4 lines are required for the clock and data, no matter what the resolution of the rotary encoder is. The RS 422 interface is optically isolated from the power supply.

**SSI signal course Standard**

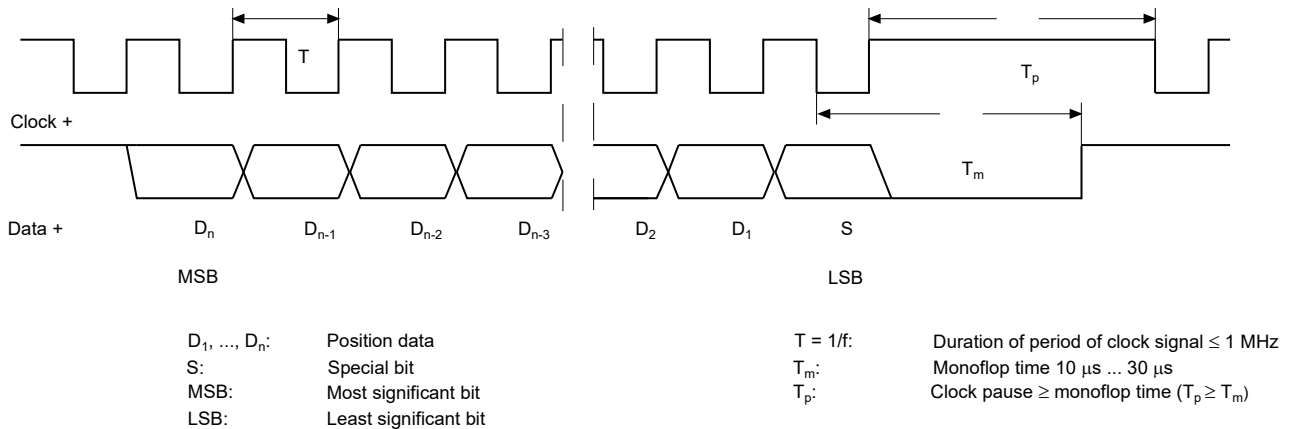

**SSI output format Standard**

- At idle status signal lines "Data +" and "Clock +" are at high level (5 V).
- The first time the clock signal switches from high to low, the data transfer in which the current information (position data (D<sub>n</sub>) and special bit (S)) is stored in the encoder is introduced.
- The highest order bit (MSB) is applied to the serial data output of the encoder with the first rising pulse edge.
- The next successive lower order bit is transferred with each following rising pulse edge.
- After the lowest order bit (LSB) has been transferred the data line switches to low until the monoflop time T<sub>m</sub> has expired.
- No subsequent data transfer can be started until the data line switches to high again or the time for the clock pause T<sub>p</sub> has expired.
- After the clock sequence is complete, the monoflop time T<sub>m</sub> is triggered with the last falling pulse edge.
- The monoflop time T<sub>m</sub> determines the lowest transmission frequency.

**SSI output format ring slide operation (multiple transmission)**

- In ring slide operation, multiple transmission of the same data word over the SSI interface makes it possible to offer the possibility of detecting transmission errors.
- In multiple transmission, 25 bits are transferred per data word in standard format.
- If the clock change is not interrupted after the last falling pulse edge, ring slide operation automatically becomes active. This means that the information that was stored at the time of the first clock change is generated again.
- After the first transmission, the 26<sup>th</sup> pulse controls data repetition. If the 26<sup>th</sup> pulse follows after an amount of time greater than the monoflop time T<sub>m</sub>, a new current data word will be transmitted with the following pulses.



If the pulse line is exchanged, the data word is generated offset. Ring slide operation is possible up to max. 13 bits.

**Block diagram**

**Line length**

Release date: 2024-03-11 Date of issue: 2024-03-11 Filename: t157828\_eng.pdf

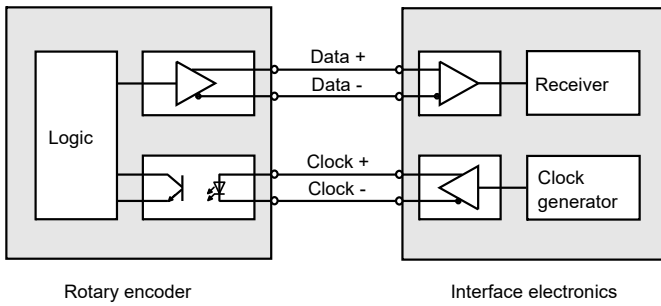

Line length in m	Baudrate in kHz
< 50	< 400
< 100	< 300
< 200	< 200
< 400	< 100

**Inputs**

The selection of the counting direction input (cw/ccw) is activated with 0-level. The zero-set input (PRESET 1) is activated with 1-level.

zero-set input (PRESET 1)

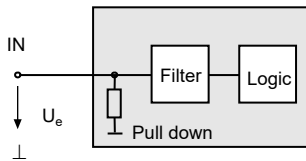

Input for selection of counting direction (cw/ccw)

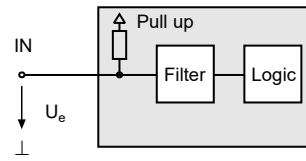

**Type Code**

Release date: 2024-03-11 Date of issue: 2024-03-11 Filename: t157828\_eng.pdf



Every encoder manufactured by Pepperl+Fuchs leaves the factory in a perfect condition. In order to ensure this quality as well as a faultless operation, the following specifications have to be taken into consideration:

- Avoid any impact on the housing and in particular on the encoder shaft as well as the axial and radial overload of the encoder shaft.
- The accuracy and service life of the encoder is guaranteed only, if a suitable coupling is used.
- The operating voltage for the encoder and the follow-up device (e. g. control) has to be switched on and off simultaneously.
- Any wiring work has to be carried out with the system in a dead condition.
- The maximum operating voltages must not be exceeded. The devices have to be operated at extra-low safety voltage.

**Notes on connecting the electric screening**

The immunity to interference of a plant depends on the correct screening. In this field installation faults occur frequently. Often the screen is applied to one side only, and is then soldered to the earthing terminal with a wire, which is a valid procedure in LF engineering. However, in case of EMC the rules of HF engineering apply.

One basic goal in HF engineering is to pass the HF energy to earth at an impedance as low as possible as otherwise energy would discharge into the cable. A low impedance is achieved by a large-surface connection to metal surfaces.

The following instructions have to be observed:

- Apply the screen on both sides to a "common earth" in a large surface, if there is no risk of equipotential currents.
- The screen has to be passed behind the insulation and has to be clamped on a large surface below the tension relief.
- In case of cable connections to screw-type terminals, the tension relief has to be connected to an earthed surface.
- If plugs are used, metallised plugs only should be fitted (such as sub D plugs with metallised housing). Please observe the direct connection of the tension relief to the housing.

Advantage:	metallised connector, shield
	clamped with the strain relief
	clamp
Disadvantage:	soldering shield on

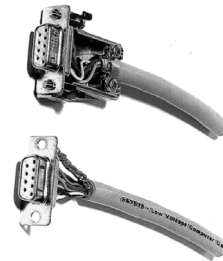

**Safety instructions**

Please observe the national safety and accident prevention regulations as well as the subsequent safety instructions in these operating instructions when working on encoders.

If failures cannot be remedied, the device has to be shut down and has to be secured against accidental operation. Repairs may be carried out only by the manufacturer. Entry into and modifications of the device are not permissible.

Tighten the clamping ring only, if a shaft has been fitted in the area of the clamping ring (hollow shaft encoders).

Tighten all screws and plug connectors prior to operating the encoder.

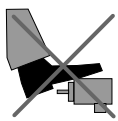

Do not stand on the encoder!

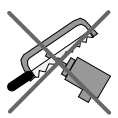

Do not remachine the drive shaft!

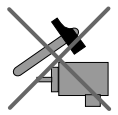

Avoid impact!



Do not remachine the housing!

Release date: 2024-03-11 Date of issue: 2024-03-11 Filename: t157828\_eng.pdf