

Temperature Multi-Input FieldConnex® Fieldbus RD0-TI-Ex8.FF.*

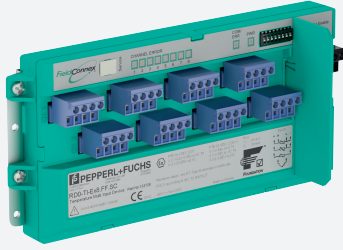

- For 8 temperature or analog sensors
- Installation in Zone 1/Div. 1, intrinsically safe
- Sensors in Zone 0/Div. 1
- Connection to fieldbus acc. to FISCO or Entity
- For FOUNDATION Fieldbus H1
- PCS integration via device description and function blocks
- Concentrator method for simplified configuration
- Monitors sensor condition
- For T/C, RTD 2-, 3-, 4-wire, voltage and resistance
- Cold junction compensation
- Removable terminals

Temperature multi-input, electronic component for control cabinet installation



Function

The Temperature Multi-Input (TM-I) for DIN rail installation connects up to 8 analog inputs to the DCS via fieldbus. It is installed in a typically pre-wired field enclosure close to the sensors in the hazardous area. The TM-I is certified intrinsically safe and as associated apparatus: inputs are intrinsically safe even when the fieldbus connection is not. Analog inputs can be resistance temperature sensors with 2, 3, and 4 wires, measuring sensors, thermocouples, or millivolt signals.

The TM-I communicates all data, configuration, and alarms via one fieldbus address and function blocks (8xAI or 1xMAI) to the DCS. For simplified configuration it supports the concentrator method: inputs can be configured all at once or individually. Fieldbus powers the sensors and the temperature interface itself, additional power or wiring is not required.

Cold junction compensation for thermocouples is integrated. The TM-I detects and reports lead breakage and short circuit conditions.

Connection

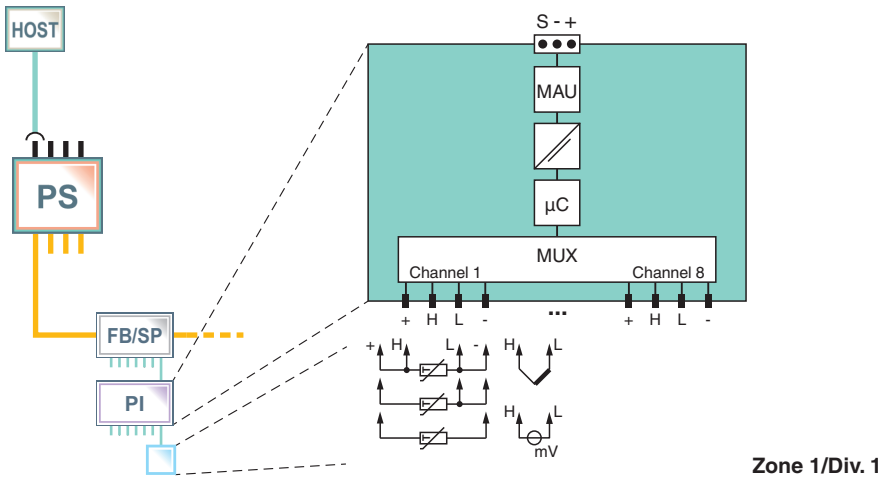

Technical Data

General specifications	
Design / Mounting	Cabinet installation
Installation in hazardous area	Zone 1 / Div. 1
Fieldbus connection	
Fieldbus type	FOUNDATION Fieldbus
Physical layer profile	profile type 511 (FISCO), profile type 111 (Entity)
ITK version	6.2.0 (DEV_REV 02)

Release date: 2025-02-07 Date of issue: 2025-02-07 Filename: t158061_eng.pdf

Technical Data

Implementation	resource block 1x RS function block 8x AI, 1x MAI transducer block 8x sensor TB, 1x concentrator TB	
Execution time	AI, MAI 40 ms max.	
Macro cycle	typical for one device 8xAI or 1xMAI max. 500 ms	
Firmware update	via separate plug connection	
FDE (Fault Disconnect Equipment)	6.7 mA	
Polarity	not polarity sensitive	
Rated voltage	U_N	9 ... 32 V
Rated current	I_N	max. 23 mA
Indicators/operating means		
LED PWR	green: on, bus voltage existent	
LED COM ERR	red, continuous lightning: hardware error; red, flashing: no bus activities or bus fault; off: no error	
LED CHANNEL ERROR	red: 2 Hz flashing: lead breakage, overrange; off: no error	
Input		
Number	8	
Sensor types	see table 1	
Grounding	grounding of thermoelements possible	
Error detection	lead breakage, wiring error, hardware device error	
Common mode voltage	Input to Input 600 V _{peak}	
Transfer characteristics		
Deviation		
Cold junction compensation	± 0.5 °C (32.9 °F)	
Resolution/accuracy	see table 2	
Influence of ambient temperature	see table 3	
Linearization	T/C input 0.1°C RTD input 0.03°C	
Internal measurement cycle	for all sensor types max. 1 s	
Galvanic isolation		
Fieldbus/inputs	safe galvanic isolation acc. to EN 60079-11, voltage peak value 375 V	
Directive conformity		
Electromagnetic compatibility		
Directive 2014/30/EU	EN 61326-1:2013	
Standard conformity		
Galvanic isolation	EN 60079-11	
Electromagnetic compatibility	NE 21:2011	
Degree of protection	IEC 60529	
Fieldbus standard	IEC 61158-2	
Shock resistance	EN 60068-2-27	
Vibration resistance	EN 60068-2-6	
Ambient conditions		
Ambient temperature	-40 ... 70 °C (-40 ... 158 °F) hazardous area -40 ... 85 °C (-40 ... 185 °F) safe area	
Storage temperature	-40 ... 85 °C (-40 ... 185 °F)	
Relative humidity	≤ 95 % non-condensing	
Shock resistance	15 g , 11 ms	
Vibration resistance	5 g , 10 ... 150 Hz	
Corrosion resistance	acc. to ISA-S71.04-1985, severity level G3	
Mechanical specifications		
Connection type	plug-in terminals , spring terminal and screw terminal	
Core cross section		
Bus	up to 2.5 mm ²	
Inputs	up to 2.5 mm ²	
Housing material	Polycarbonate	

Technical Data

Degree of protection	IP20
Mass	360 g
Mounting	DIN rail mounting
Data for application in connection with hazardous areas	
EU-type examination certificate	PTB 03 ATEX 2237
Marking	Ⓜ II 2 (1) G Ex ia [ia Ga] IIC T4 Gb , Ⓜ II (1) G [Ex ia Ga] IIC , Ⓜ II (1) D [Ex ia Da] IIC , Ⓜ II 3 G Ex ic IIC T4 Gc
Bus	FISCO see EC-Type Examination Certificate
Inputs	see EC-Type Examination Certificate
Certificate	PTB 03 ATEX 2238 X
Marking	Ⓜ II 3 G Ex nA IIC T4 Gc
Galvanic isolation	
Bus	see Statement of Conformity
Input	see EC-Type Examination Certificate
Directive conformity	
Directive 2014/34/EU	EN IEC 60079-0:2018+AC:2020 , EN 60079-11:2012 , EN 60079-15:2010
International approvals	
FM approval	
FM certificate	FM18US0054X , FM18CA0027X
Control drawing	16-473FM-12A
IECEX approval	
IECEX certificate	IECEX PTB 05.0001 IECEX PTB 05.0002X
IECEX marking	Ex ia [ia Ga] IIC T4 Gb [Ex ia Ga] IIC [Ex ia Da] IIC Ex ic IIC T4 Gc Ex nA IIC T4 Gc
General information	
Supplementary information	EC-Type Examination Certificate, Statement of Conformity, Declaration of Conformity, Attestation of Conformity and instructions have to be observed where applicable. For information see www.pepperl-fuchs.com .

Assembly

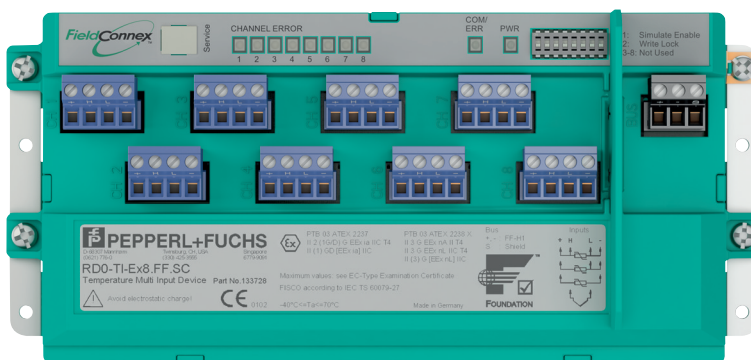

Release date: 2025-02-07 Date of issue: 2025-02-07 Filename: t158061_eng.pdf

Additional Information

Type Code

Type Code	Description
RD0-TI-Ex8.FF.ST	Fieldbus temperature interface with 8 inputs with screw terminals without field housing for mounting on DIN rail in cabinet
RD0-TI-Ex8.FF.SC	Fieldbus temperature interface with 8 inputs with spring terminals without field housing for mounting on DIN rail in cabinet

Dimensions and Assembly

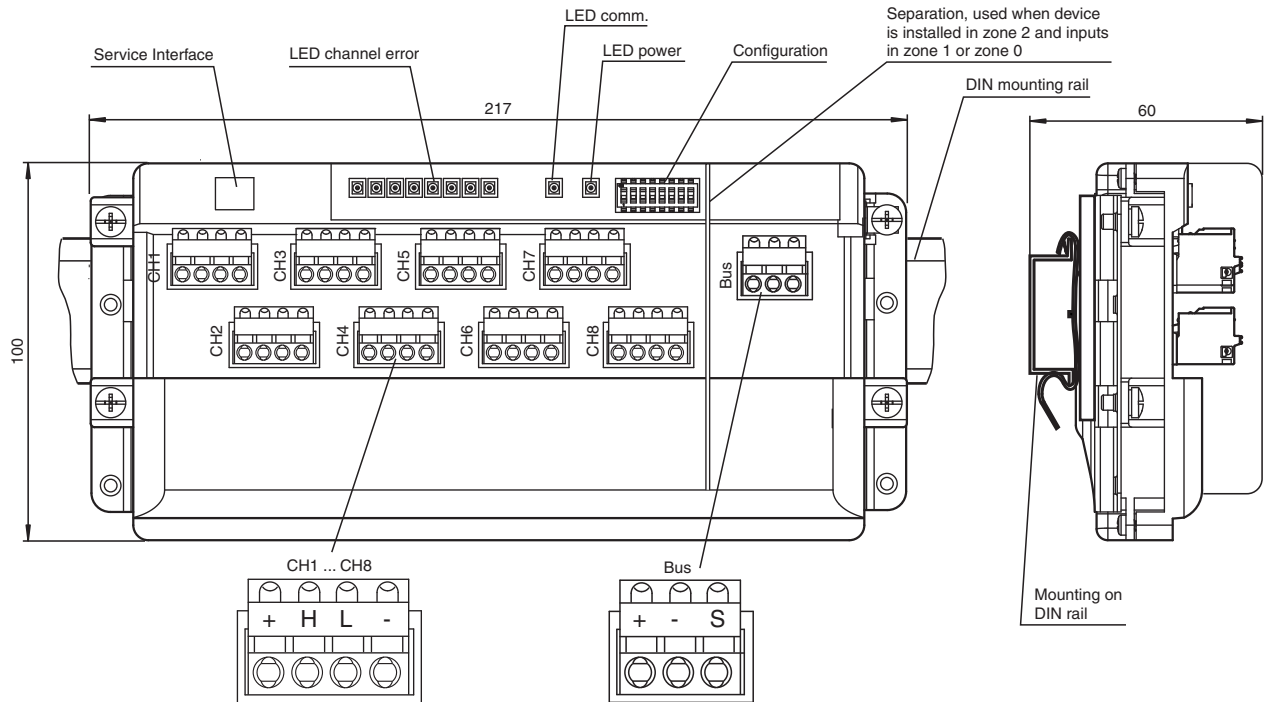

Figure 1: RD0-TI-Ex8.FF.SC

Installation

see manual

Release date: 2025-02-07 Date of issue: 2025-02-07 Filename: t158061_eng.pdf

Technical Features

Table 1: Sensor types

Thermocouple			
Type	Standard	Range (°C)	Range (°F)
B	EN 60584-1	300 ... 1800	572 ... 3272
E	EN 60584-1	-200 ... 1000	-328 ... 1832
J	EN 60584-1	-200 ... 1000	-328 ... 1832
K	EN 60584-1	-200 ... 1372	-328 ... 2502
N	EN 60584-1	-200 ... 1300	-328 ... 2372
R	EN 60584-1	0 ... 1768	-32 ... 3214
S	EN 60584-1	0 ... 1768	-32 ... 3214
T	EN 60584-1	-200 ... 400	-328 ... 752
W5Re/ W26Re	ASTM 988-96	0 ... 2000	-32 ... 3632

Input voltage	
Type	Range (mV)
Range 1	-100 ... 150

RTD			
Type	Standard	Range (°C)	Range (°F)
Pt50	EN 60751 (ITS90)	-200 ... 850	-328 ... 1562
Pt100	EN 60751 (ITS90)	-200 ... 850	-328 ... 1562
Pt100	JIS C 1604-1989	-200 ... 630	-328 ... 1166
Pt200	EN 60751 (ITS90)	-200 ... 850	-328 ... 1562
Pt500	EN 60751 (ITS90)	-200 ... 850	-328 ... 1562
Pt1000	EN 60751 (ITS90)	-200 ... 850	-328 ... 1562
Ni100	DIN 43760-1987	-60 ... 250	-76 ... 482
Ni120	Minco standard	-80 ... 320	-112 ... 608
Ni200	DIN 43760-1987	-60 ... 250	-76 ... 482
Cu10	SAMA RC21-4-1966	-70 ... 150	-94 ... 302

Resistance input	
Type	Range (Ohm)
Range 1	0 ... 650
Range 2	0 ... 1300
Range 3	0 ... 2600
Range 4	0 ... 5200

Table 2: Accuracy

Thermocouple				
Type	Range (°C)	Range (°F)	Accuracy	
			(°C)	(°F)
B	300 ... 600	572 ... 1112	± 3.32	± 5.98
	600 ... 1200	1112 ... 2192	± 1.77	± 3.19
	1200 ... 1800	2192 ... 3272	± 1.08	± 1.94
E	-200 ... -50	-328 ... -58	± 0.42	± 0.76
	-50 ... 1000	-58 ... 1832	± 0.31	± 0.56
J	-200 ... 0	-328 ... 32	± 0.48	± 0.86
	0 ... 1000	32 ... 1832	± 0.31	± 0.56
K	-200 ... 0	-328 ... 32	± 0.68	± 1.22
	0 ... 1372	32 ... 2502	± 0.43	± 0.77
N	-200 ... -100	-328 ... -148	± 1.03	± 1.85
	-100 ... 500	-148 ... 932	± 0.54	± 0.97
	500 ... 1300	932 ... 2372	± 0.39	± 0.70
R	0 ... 350	32 ... 662	± 1.93	± 3.47
	350 ... 1768	662 ... 3214	± 1.16	± 2.09
S	0 ... 550	32 ... 1022	± 1.92	± 3.46
	550 ... 1768	1022 ... 3214	± 1.15	± 2.07
T	-200 ... -50	-328 ... -58	± 0.66	± 1.19
	-50 ... 400	-58 ... 752	± 0.35	± 0.63
W5Re/ W26Re	0 ... 800	-32 ... 1472	± 0.80	± 1.45
	800 ... 2000	1472 ... 3632	± 1.05	± 1.89

Input voltage	
Type	Accuracy (µV)
Range 1	± 20

RTD		
Type	Accuracy	
	(°C)	(°F)
Pt50	± 0.77	± 1.39
Pt100	± 0.33	± 0.59
Pt100 JIS	± 0.33	± 0.59
Pt200	± 0.33	± 0.59
Pt500	± 0.31	± 0.56
Pt1000	± 0.31	± 0.56
Ni100	± 0.18	± 0.32
Ni120	± 0.18	± 0.32
Ni200	± 0.18	± 0.32
Cu10	± 2.99	± 5.38

Resistance input	
Type	Accuracy (mOhm)
Range 1	± 115
Range 2	± 230
Range 3	± 460
Range 4	± 920

Release date: 2025-02-07 Date of issue: 2025-02-07 Filename: t158061_eng.pdf

Table 3: Influence of ambient temperature

Thermocouple			
Type	Range (°C)	Range (°F)	Deviation (°C/K)
B	300 ... 600	572 ... 1112	± 0.0060
	600 ... 1200	1112 ... 2192	± 0.0131
	1200 ... 1800	2192 ... 3272	± 0.0242
E	-200 ... -50	-328 ... -58	± 0.0070
	-50 ... 200	-58 ... 392	± 0.0036
	200 ... 1000	392 ... 1832	± 0.0203
J	-200 ... 0	-328 ... 32	± 0.0072
	0 ... 200	32 ... 392	± 0.0039
	200 ... 1000	392 ... 1832	± 0.0243
K	-200 ... 0	-328 ... 32	± 0.0077
	0 ... 500	32 ... 932	± 0.0097
	500 ... 1372	932 ... 2502	± 0.0323
N	-200 ... -100	-328 ... -148	± 0.0080
	-100 ... 500	-148 ... 932	± 0.0088
	500 ... 1300	932 ... 2372	± 0.0264
R	0 ... 350	32 ... 662	± 0.0057
	350 ... 800	662 ... 1472	± 0.0129
	800 ... 1768	1472 ... 3214	± 0.0338
S	0 ... 550	32 ... 1022	± 0.0094
	550 ... 800	1022 ... 1472	± 0.0135
	800 ... 1768	1472 ... 3214	± 0.0355
T	-200 ... -50	-328 ... -58	± 0.0071
	-50 ... 200	-58 ... 392	± 0.0035
	200 ... 400	392 ... 752	± 0.0067
W5Re/ W26Re	0 ... 800	-32 ... 1472	± 0.0151
	800 ... 2000	1472 ... 3632	± 0.0552

Input voltage	
Type	Deviation (µV/K)
Range 1	± 2

RTD	
Type	Deviation (°C/K)
Pt50	± 0.010
Pt100	± 0.010
Pt100 JIS	± 0.010
Pt200	± 0.010
Pt500	± 0.010
Pt1000	± 0.010
Ni100	± 0.010
Ni120	± 0.010
Ni200	± 0.010
Cu10	± 0.010

Resistance input	
Type	Deviation (mOhm/K)
Range 1	± 6
Range 2	± 6
Range 3	± 13
Range 4	± 26

Release date: 2025-02-07 Date of issue: 2025-02-07 Filename: t158061_eng.pdf