

Temperature Multi-Input FieldConnex® Fieldbus F2D0-TI-Ex8.FF.*

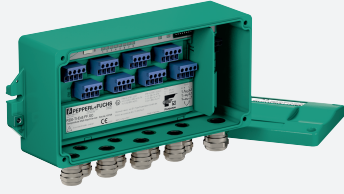

- For 8 temperature or analog sensors
- Installation in Zone 1/Div. 1, intrinsically safe
- Sensors in Zone 0/Div. 1
- Connection to fieldbus acc. to FISCO or Enty
- For FOUNDATION Fieldbus H1
- PCS integration via device description and function blocks
- Concentrator method for simplified configuration
- Monitors sensor condition
- For T/C, RTD 2-, 3-, 4-wire, voltage and resistance
- Cold junction compensation
- Removable terminals

Temperature multi-input, stand-alone device with aluminum housing for field installation



Function

This fieldbus junction box holds a temperature multi-input device for transferring signals from resistance temperature measuring sensors and thermocouples, as well as resistance and millivolt signals via FOUNDATION Fieldbus H1. The fieldbus junction box with 8 inputs can be installed in Zone 1/Div. 1 with sensors located in Zone 0/Div. 1. The housing, type F2, is made of sturdy cast aluminum for installation in rough environments. Fieldbus and field device entrances can be selected individually from a range of cable glands. Optionally, either screw terminals or spring terminals can be chosen. A tag plate is available as option.

Connection

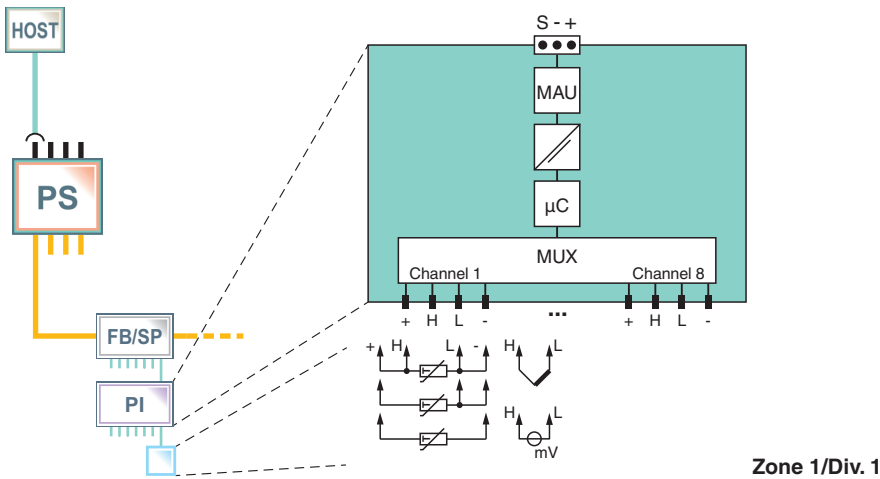

Technical Data

General specifications	
Design / Mounting	Outside installation
Installation in hazardous area	Zone 1 / Div. 1
Electronic component	Temperature Multi-Input Device RD0-TI-Ex8.FF* For technical data on installed electronic component see datasheet.
Fieldbus connection	
Fieldbus type	FOUNDATION Fieldbus
Input	
Number	8

Release date: 2025-02-07 Date of issue: 2025-02-07 Filename: t158062_eng.pdf

Technical Data

Directive conformity		
Electromagnetic compatibility		
Directive 2014/30/EU		EN 61326-1:2013
Standard conformity		
Galvanic isolation		EN 60079-11
Electromagnetic compatibility		NE 21:2011
Degree of protection		IEC 60529
Fieldbus standard		IEC 61158-2
Shock resistance		EN 60068-2-27
Vibration resistance		EN 60068-2-6
Ambient conditions		
Ambient temperature		see table 1
Storage temperature		-40 ... 85 °C (-40 ... 185 °F)
Relative humidity		≤ 95 % non-condensing
Shock resistance		15 g , 11 ms
Vibration resistance		10 g , 10 ... 150 Hz
Corrosion resistance		acc. to ISA-S71.04-1985, severity level G3
Mechanical specifications		
Connection type		plug-in terminals , spring terminal and screw terminal
Core cross section		
Bus		up to 2.5 mm ²
Inputs		up to 2.5 mm ²
Cable diameter		see table 2
Cable gland		sensor inputs M16, fieldbus M20
Housing material		Aluminum
Degree of protection		IP67
Mass		1800 g
Mounting		wall mounting
Data for application in connection with hazardous areas		
EU-type examination certificate		PTB 03 ATEX 2237
Marking		⊕ II 2 (1) G Ex ia [ia Ga] IIC T4 Gb , ⊕ II (1) G [Ex ia Ga] IIC , ⊕ II (1) D [Ex ia Da] IIIC , ⊕ II 3 G Ex ic IIC T4 Gc
Bus		FISCO see EC-Type Examination Certificate
Inputs		see EC-Type Examination Certificate
Certificate		PTB 03 ATEX 2238 X
Marking		⊕ II 3 G Ex nA IIC T4 Gc
Galvanic isolation		
Bus		see Statement of Conformity
Input		see EC-Type Examination Certificate
Directive conformity		
Directive 2014/34/EU		EN IEC 60079-0:2018+AC:2020 , EN 60079-11:2012 , EN 60079-15:2010
International approvals		
FM approval		
FM certificate		FM18US0054X , FM18CA0027X
Control drawing		16-473FM-12A
IECEx approval		
IECEx certificate		IECEx PTB 05.0001 IECEx PTB 05.0002X
IECEx marking		Ex ia [ia Ga] IIC T4 Gb [Ex ia Ga] IIC [Ex ia Da] IIIC Ex ic IIC T4 Gc Ex nA IIC T4 Gc
General information		

Technical Data

Supplementary information

EC-Type Examination Certificate, Statement of Conformity, Declaration of Conformity, Attestation of Conformity and instructions have to be observed where applicable. For information see www.pepperl-fuchs.com.

Assembly

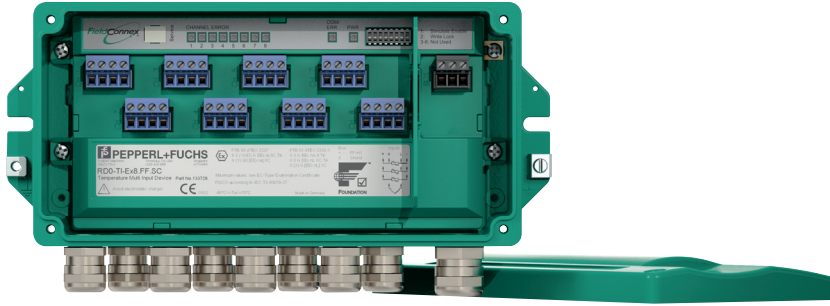

Additional Information

Type Code

Type of housing

F2D0 Field housing, aluminum, IP67

Type of device

TI Temperature Multi-Input Device

Explosion protection method

Ex intrinsically safe

Number of inputs

8

Fieldbus type

FF FOUNDATION Fieldbus

Type of connection

CG Cable gland, plastic

CGB Cable gland, nickel plated brass

CGS Cable gland, stainless steel

Type of terminal

ST Screw terminals

SC Spring terminals

F2D0	-	TI	-	Ex	8	.	FF	.		.	
A	-	B	-	C	D	.	E	.	F	.	G

Identification for assignment of the type code to the following tables

Example:

F2D0-TI-Ex8.FF.CGB.ST: Temperature Multi-Input Device in aluminum housing with cable glands made of nickel plated brass and 8 inputs with screw terminals

Note:

Contact your Pepperl+Fuchs representative to check the availability of individual variants.

Dimensions and Assembly

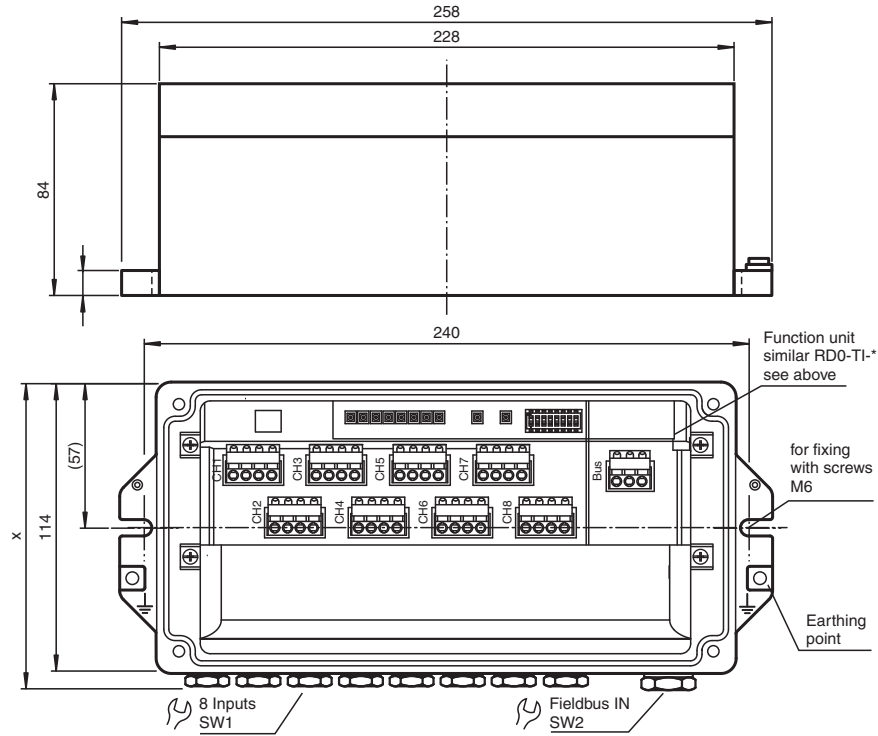

Figure 1: F2D0-TI-Ex8.FF.CGB.SC

Installation

see manual

Electrical Connection

Variations of cable connections, housing types and temperature ranges

Type of connection, identification F	Type of cable connection	Number of inputs, identification D	F2 housing, outside dimension "X" (mm)	Temperature range for use in hazardous area (°C)	Temperature range for use in safe area (°C)
CG	Terminals, cable glands plastic	8	140	-30 ... 70	-30 ... 85
CGB	Terminals, cable glands nickel plated brass	8	140	-40 ... 70	-40 ... 85
CGS	Terminals, cable glands stainless steel	8	140	-40 ... 70	-40 ... 85

Table 1

Cable diameter depending on cable gland

Type of connection, identification F	Sensors				Fieldbus			
	Type	Material	Cable diameter (mm)	SW1	Type	Material	Cable diameter (mm)	SW2
CG	M16 x 1.5	Plastic	5 ... 10	20	M20 x 1.5	Plastic	5 ... 13	24
CGB	M16 x 1.5	Nickel plated brass	5 ... 10	20	M20 x 1.5	Nickel plated brass	7 ... 12	24
CGS	M16 x 1.5	Stainless steel	5 ... 9	17	M20 x 1.5	Stainless steel	7 ... 12	24

Table 2

Release date: 2025-02-07 Date of issue: 2025-02-07 Filename: t158062_eng.pdf