



## Com Unit for MODBUS TCP FB8211\*

- Interface between the I/O modules and the PCS/PLC
- Communication via MODBUS TCP
- Installation in suitable enclosures in Zone 1
- Module can be exchanged under voltage (hot swap)
- Com unit for 80 analog or 184 digital channels
- HART communication via MODBUS TCP
- Configuration via FDT 1.2 DTM
- Non-volatile memory for configuration and parameter settings
- Self configuration in redundant systems
- Permanently self-monitoring
- Outputs drive to safe state in case of failures

Com Unit for MODBUS TCP



### Function

The MODBUS TCP com unit forms the interface between the I/O modules on the backplane and the process control system. It supports all single width and dual width I/O modules. Thereby signals from NAMUR sensors, mechanical contacts, high-power solenoid drivers, power relays, sounders, and alarm LEDs are transported to the higher-level bus system. The com unit can be easily configured via DTM and supports redundancy as well as HART.

### Connection

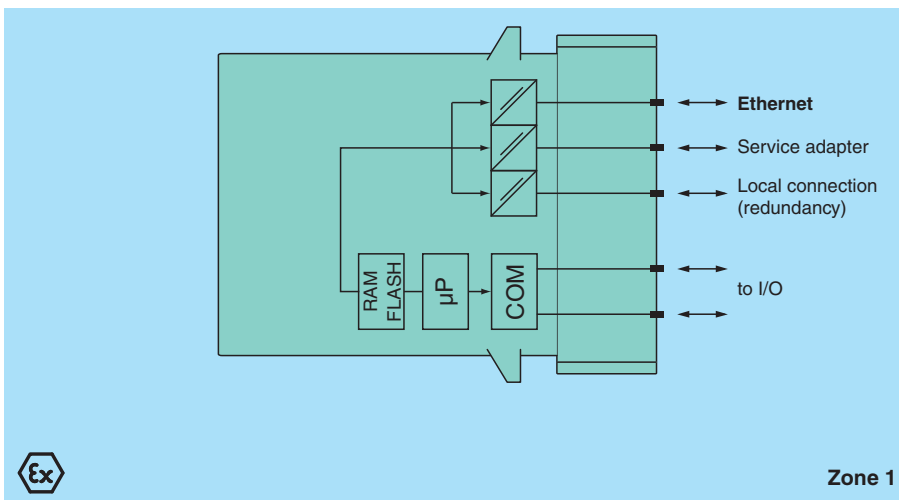

### Technical Data

#### Supply

Connection	backplane bus	
Rated voltage	U <sub>r</sub>	5 V DC , only in connection with the power supplies FB92**
Power consumption	2.5 W	

#### Fieldbus interface

Fieldbus type	MODBUS TCP
---------------	------------

#### Ethernet Interface

Connection type	wired to Ex e terminals via backplane
Transfer rate	10 MBit/s

Release date: 2020-04-30 Date of issue: 2020-04-30 Filename: t159199\_eng.pdf

## Technical Data

Station connection	directly to PCS or PLC or via hubs or switches
Bus length	max. 100 m (Ethernet standard)
Addressing	IP address assigned via Ethernet
Ethernet address	IP V4 address (factory standard setting: 0.0.0.0, auto IP, DHCP)
Number of channels per station	max. 80 analog, max. 184 digital
Supported I/O modules	all FB remote I/O modules
HART communication	via Ethernet
<b>Internal bus</b>	
Connection	backplane bus
Redundancy	via left front connector
<b>Service interface</b>	
Connection	via right front connector in connection with service adapter SERV8001
<b>Indicators/settings</b>	
LED indication	LED green (power supply): On = operating, fast flash = cold start LED red (collective alarm): On = internal fault, flashing = no Modbus TCP connection LED yellow (operating mode): flashing 1 (1:1 ratio) = active, normal operation; flashing 2 (7:1 ratio) = active, simulation
<b>Directive conformity</b>	
Electromagnetic compatibility	
Directive 2014/30/EU	EN 61326-1
<b>Conformity</b>	
Electromagnetic compatibility	NE 21
Degree of protection	IEC 60529
Fieldbus standard	IEEE 802.3
Environmental test	EN 60068-2-14
Shock resistance	EN 60068-2-27
Vibration resistance	EN 60068-2-6
Damaging gas	EN 60068-2-42
Relative humidity	EN 60068-2-56
<b>Ambient conditions</b>	
Ambient temperature	-20 ... 60 °C (-4 ... 140 °F)
Storage temperature	-25 ... 85 °C (-13 ... 185 °F)
Relative humidity	95 % non-condensing
Shock resistance	shock type I, shock duration 11 ms, shock amplitude 15 g, number of shocks 18
Vibration resistance	frequency range 10 ... 150 Hz; transition frequency: 57.56 Hz, amplitude/acceleration ± 0.075 mm/1 g; 10 cycles frequency range 5 ... 100 Hz; transition frequency: 13.2 Hz amplitude/acceleration ± 1 mm/0.7 g; 90 minutes at each resonance
Damaging gas	designed for operation in environmental conditions acc. to ISA-S71.04-1985, severity level G3
<b>Mechanical specifications</b>	
Degree of protection	IP20 (module) , a separate housing is required acc. to the system description
Connection	via backplane
Mass	approx. 750 g
Dimensions	57 x 107 x 132 mm (2.2 x 4.2 x 5.2 inch)
<b>Data for application in connection with hazardous areas</b>	
EU-Type Examination Certificate	PTB 97 ATEX 1074 U
Marking	Ⓜ II 2 G Ex d [ib] IIC Gb
Directive conformity	
Directive 2014/34/EU	EN 60079-0:2009 EN 60079-1:2007 EN 60079-11:2007 EN 60079-26:2007 EN 61241-11:2006
<b>International approvals</b>	
EAC approval	Russia: RU C-IT.MIII06.B.00129
Marine approval	

## Technical Data

Lloyd Register	15/20021
DNV GL Marine	TAA0000034
American Bureau of Shipping	T1450280/UN
<b>General information</b>	
System information	The module has to be mounted in appropriate backplanes (FB92**) in Zone 1, 2, or outside hazardous areas. Observe the corresponding EC-type examination certificate.
Supplementary information	EC-Type Examination Certificate, Statement of Conformity, Declaration of Conformity, Attestation of Conformity and instructions have to be observed where applicable. For information see <a href="http://www.pepperl-fuchs.com">www.pepperl-fuchs.com</a> .

## Assembly

### Front view

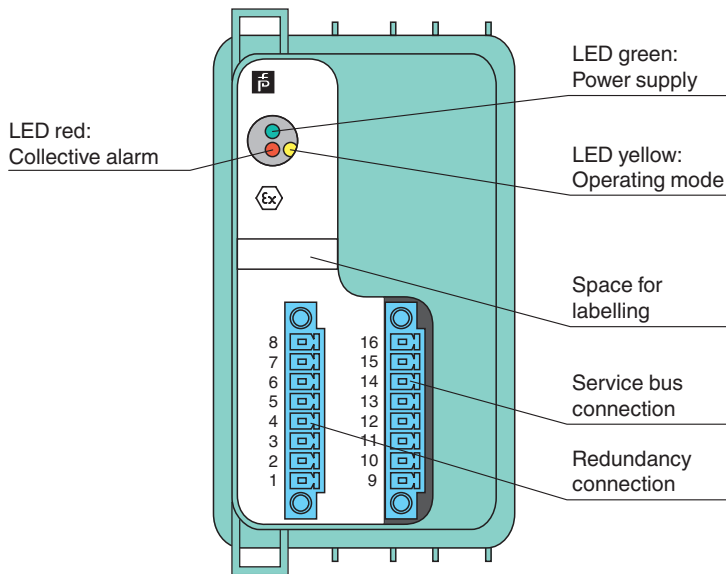

## Accessories

	DTM LB/FB
---	-----------

Release date: 2020-04-30 Date of issue: 2020-04-30 Filename: t159199\_eng.pdf

## Product Versions

Bus couplers are available with different firmware versions. The type code extension \* designates the firmware version.