



Absolute rotary encoder

ENA58IL-S***-SSI

- Solid shaft
- SSI interface
- Up to 32 Bit multiturm
- Free of wear magnetic sampling
- High resolution and accuracy
- Additionally push buttons for preset function (only model characteristic SB2, SG2)
- Up to 4096 pulses on incremental track



Function

The ENA58IL series are high precision encoders with internal magnetic sampling. This multiturm absolute encoder transmits a position value corresponding to the shaft setting via the SSI interface (Synchronous Serial Interface). The control module sends a start sequence to the absolute encoder to obtain the position data. The rotary encoder then sends the position data synchronous to the cycles of the control module. It is possible to select the counting direction with the function input.

Dimensions

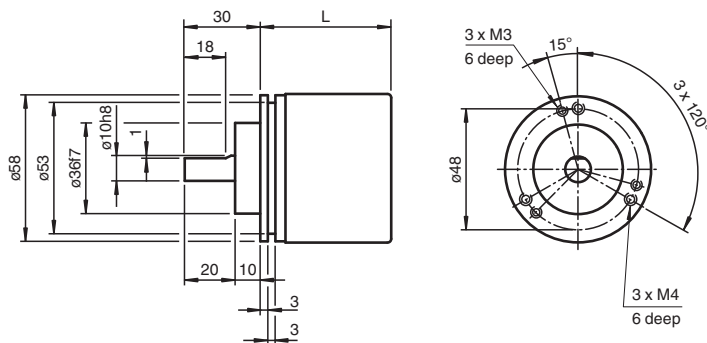

Clamping flange

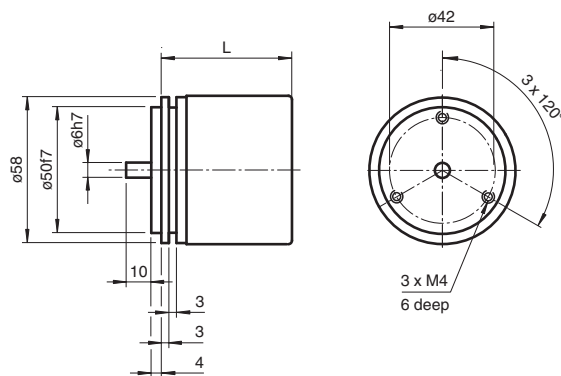

Servo flange

Dimensions

| Design | L [mm] | |
|------------|--------------|---------------|
| | Axial output | Radial output |
| Singleturn | 41.7 | 52.7 |
| Multiturn | 52.7 | |

Connections

Dimensions in mm

Cable

Connector M12

Connector M23

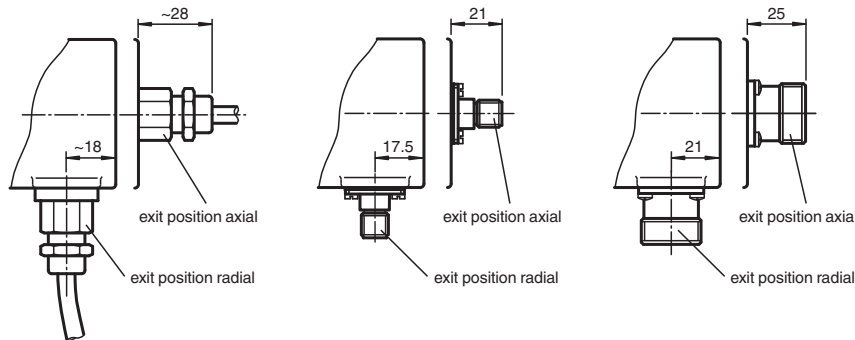

Technical Data

| General specifications | |
|----------------------------------|---|
| Detection type | magnetic sampling |
| Device type | Absolute rotary encoder |
| Linearity error | $\leq \pm 0.1^\circ$ |
| UL File Number | E223176 "For use in NFPA 79 Applications only", if UL marking is marked on the product. |
| Electrical specifications | |
| Operating voltage | U_B 4.5 ... 30 V DC (SSI, SSI + RS422) ; 10 ... 30 V DC (SSI + Push/Pull) |
| No-load supply current | I_0 typ. 50 mA |
| Power consumption | P_0 approx. 1.5 W |
| Time delay before availability | t_v < 450 ms |
| Output code | Gray code, binary code |
| Code course (counting direction) | adjustable |
| Interface | |
| Interface type | SSI ; SSI + incremental track |
| Resolution | |
| Single turn | up to 16 Bit |
| Multiturn | up to 16 Bit |
| Overall resolution | up to 32 Bit |
| Transfer rate | 0.1 ... 2 MBit/s |
| Cycle time | < 100 μ s |
| Standard conformity | RS 422 |
| Input 1 | |
| Input type | Selection of counting direction (cw/ccw) |
| Signal voltage | |
| High | 4.75 V ... U_B or unconnected (cw descending) |
| Low | 0 ... 2 V (cw ascending) |

Release date: 2025-04-28 Date of issue: 2025-04-28 Filename: t166164_eng.pdf

Technical Data

| | |
|-----------------------------------|---|
| Input current | < 6 mA |
| Switch-on delay | < 250 ms |
| Input 2 | |
| Input type | zero-set (PRESET 1) with falling edge |
| Signal voltage | |
| High | 4.75 V ... U_B |
| Low | 0 ... 2 V |
| Input current | < 6 mA |
| Signal duration | min. 1.1 s |
| Output | |
| Output type | RS422, Push/Pull |
| Signal output | A+B+/A+/B |
| Pulses | 1024, 2048, 4096 |
| Connection | |
| Connector | M12 connector, 8-pin or M23 connector, 12-pin |
| Cable | Ø7 mm, 6 x 2 x 0.14 mm ² , 1 m (cable length, see order code) |
| Standard conformity | |
| Degree of protection | DIN EN 60529, IP65 or IP67 (not for M23 device plug) |
| Climatic testing | DIN EN 60068-2-3, no moisture condensation |
| Emitted interference | EN 61000-6-4:2007 |
| Noise immunity | EN 61000-6-2:2005 |
| Shock resistance | DIN EN 60068-2-27, 200 g, 6 ms |
| Vibration resistance | DIN EN 60068-2-6, 20 g, 10 ... 1000 Hz |
| Approvals and certificates | |
| UL approval | cULus Listed, General Purpose, Class 2 Power Source , if UL marking is marked on the product. |
| Ambient conditions | |
| Operating temperature | cable, movable installation: -5 ... 70 °C (23 ... 158 °F), cable, fixed installation: -30 ... 70 °C (-22 ... 158 °F) connector models: -40 ... 85 °C (-40 ... 185 °F) |
| Storage temperature | -40 ... 85 °C (-40 ... 185 °F) |
| Relative humidity | 98 % , no moisture condensation |
| Mechanical specifications | |
| Material | |
| Housing | nickel-plated steel , painted |
| Flange | Aluminum |
| Shaft | Stainless steel |
| Mass | approx. 300 g , with cable |
| Rotational speed | max. 12000 min ⁻¹ |
| Moment of inertia | 50 gcm ² |
| Starting torque | < 5 Ncm |
| Shaft load | |
| Axial | 40 N |
| Radial | 110 N |

Connection

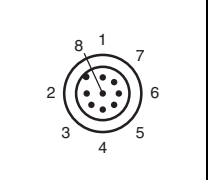
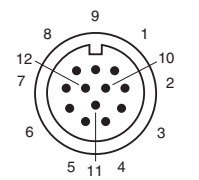
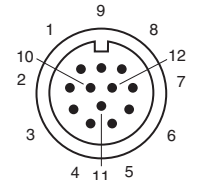
| Signal | Cable, 12-core | Connector M12, 8-pin | Connector M23, 12-pin, cw | Connector M23, 12-pin, ccw | Explanation |
|-----------------|----------------|---|---|--|---|
| GND (encoder) | White | 1 | 1 | 1 | Power supply |
| U_B (encoder) | Brown | 2 | 2 | 8 | Power supply |
| Clock (+) | Green | 3 | 3 | 3 | Positive cycle line |
| Clock (-) | Yellow | 4 | 4 | 11 | Negative cycle line |
| Data (+) | Grey | 5 | 5 | 2 | Positive transmission data |
| Data (-) | Pink | 6 | 6 | 10 | Negative transmission data |
| A | Black | | 7 | 12 | Incremental track A |
| V/R | Red | 8 | 8 | 5 | Input for selection of counting direction |
| PRESET 1 | Blue | 7 | 9 | 9 | Zero-setting input |
| B | Grey/Pink | | 10 | 4 | Incremental track B |
| \bar{A} | Violet | | 11 | 6 | Incremental track \bar{A} |
| \bar{B} | Red/Blue | | 12 | 7 | Incremental track \bar{B} |
| | |  |  |  | |

Operation

Signal output

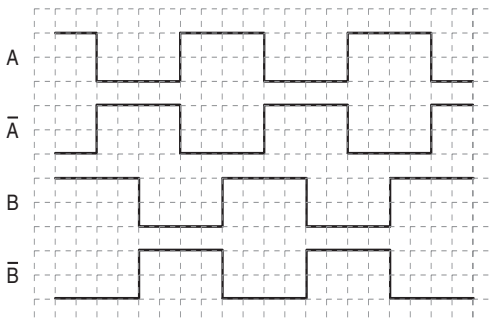

cw - with view onto the shaft

Interface

The Synchronous Serial Interface was specially developed for transferring the output data of an absolute encoder to a control device. The control module sends a clock bundle and the absolute encoder responds with the position value. Thus only 4 lines are required for the clock and data, no matter what the resolution of the rotary encoder is. The RS 422 interface is optically isolated from the power supply.

SSI signal course Standard

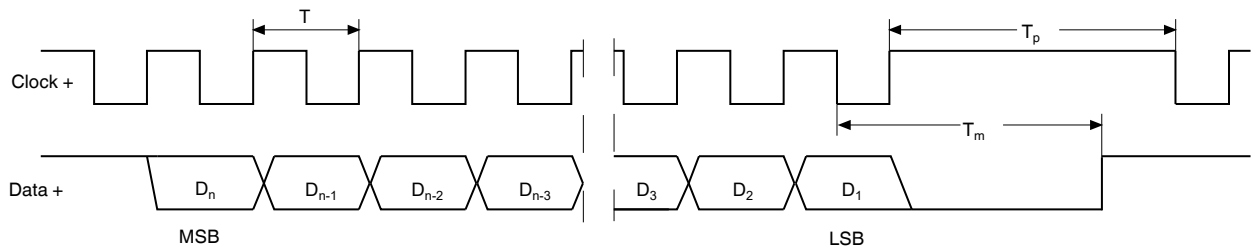

D_1, \dots, D_n : Position data
 MSB: Most significant bit
 LSB: Least significant bit
 $T = 1/f$: Duration of period of clock signal ≤ 2 MHz
 T_m : Monoflop time $20 \mu s \pm 1 \mu s$
 T_p : Clock pause \geq monoflop time ($T_p \geq T_m$)

Release date: 2025-04-28 Date of issue: 2025-04-28 Filename: t166164_eng.pdf

SSI output format Standard

- At idle status signal lines "Data +" and "Clock +" are at high level (5 V).
- The first time the clock signal switches from high to low, the data transfer in which the current information (position data (D_n)) is stored in the encoder is introduced.
- The highest order bit (MSB) is applied to the serial data output of the encoder with the first rising pulse edge.
- The next successive lower order bit is transferred with each following rising pulse edge.
- After the lowest order bit (LSB) has been transferred the data line switches to low until the monoflop time T_m has expired.
- No subsequent data transfer can be started until the data line switches to high again or the time for the clock pause T_p has expired.
- After the clock sequence is complete, the monoflop time T_m is triggered with the last falling pulse edge.
- The monoflop time T_m determines the lowest transmission frequency.

SSI output format ring slide operation (multiple transmission)

- In ring slide operation, multiple transmission of the same data word over the SSI interface makes it possible to offer the possibility of detecting transmission errors.
- In multiple transmission, n bits are transferred per data word in standard format. The value n equals the total resolution of the encoder.
As an example: a multiturn encoder with a resolution of 8192 steps/revolution (13 bit) and a max. number of 4096 revolutions (12 bit) has a total resolution of n = 25 bit.
- If the clock change is not interrupted after the last falling pulse edge, ring slide operation automatically becomes active. This means that the information that was stored at the time of the first clock change is generated again.
- After the first position transmission, the n+1 pulse controls data repetition. If the n+1 pulse follows after an amount of time greater than the monoflop time T_m, a new current data word will be transmitted with the following pulses.



If the pulse line is exchanged, the data word is generated offset.

Block diagram

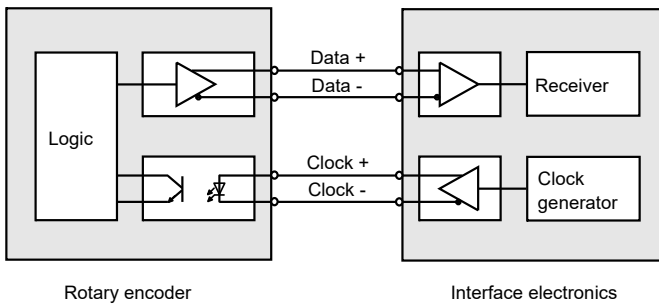

Line length

| Line length in m | Baudrate in kHz |
|------------------|-----------------|
| < 50 | < 400 |
| < 100 | < 300 |
| < 200 | < 200 |
| < 400 | < 100 |

Parameterization

Push buttons on encoder with model characteristic SB2, SG2

In addition to the electrical preset function (PRESET 1) these models are equipped with 2 push buttons for manually setting the zero point of the rotary encoder.

Manually zero set

1. Simultaneously press and hold the push buttons A and B for 2 s.

After releasing the push buttons the rotary encoder sets the current position as zero point.

Type Code

Release date: 2025-04-28 Date of issue: 2025-04-28 Filename: t166164_eng.pdf



Connection type

- C1** Cable, 1 m
- C2** Cable, 2 m
- C5** Cable, 5 m
- CA** Cable, 10 m
- AA** M23 device plug, cw
- AB** M23 device plug, ccw
- BE** M12 device plug, 8-pin (not available with SSI + incremental track)

Connection alignment

- A** axial
- R** radial

Electrical interface

SG1 ... SIC see next page

Singleturn resolution

- 12** 12 bit
- 13** 13 bit
- 16** 16 bit

Multiturn resolution

- 00** Singleturn rotary encoder
- 12** Multiturn rotary encoder, 12 bit
- 14** Multiturn rotary encoder, 14 bit
- 16** Multiturn rotary encoder, 16 bit

Degree of protection

- 5** IP65
- 7** IP67 (not for M23 device plug)

Flange

- CA** Clamping flange
- SA** Servo flange

Shaft diameter

- 06** 6 mm
- 10** 10 mm

Shaft type

- S** Solid shaft

Version

- IL** Industrial Line

Size

- 58** Housing diameter: 58 mm

Device type

- ENA** Absolute rotary encoder



Electrical interface

- SG1** SSI Gray
- SB1** SSI binary
- SG2** SSI Gray, with push buttons
- SB2** SSI binary, with push buttons
- SI1** SSI Gray + 1024 pulses, Push/Pull
- SI2** SSI Gray + 2048 pulses, Push/Pull
- SI3** SSI Gray + 4096 pulses, Push/Pull
- SI4** SSI Gray + 1024 pulses, RS422
- SI5** SSI Gray + 2048 pulses, RS422
- SI6** SSI Gray + 4096 pulses, RS422
- SI7** SSI Binär + 1024 pulses, Push/Pull

Release date: 2025-04-28 Date of issue: 2025-04-28 Filename: t166164_eng.pdf

| | |
|------------|------------------------------------|
| SI8 | SSI Binär + 2048 pulses, Push/Pull |
| SI9 | SSI Binär + 4096 pulses, Push/Pull |
| SIA | SSI Binär + 1024 pulses, RS422 |
| SIB | SSI Binär + 2048 pulses, RS422 |
| SIC | SSI Binär + 4096 pulses, RS422 |