

Cable pull rotary encoder

ECA10TL - SSI



- Solid yet lightweight plastic construction
- Compact, slim design (the shaft of the mounted rotary encoder is used to provide the function of the drum bearing)
- Coupling-free adaptation
- Wide range of mounting options
- Rust and acid-resistant measuring cable
- Very high level of linearity and repeatability
- SSI interface
- Free of wear magnetic sampling
- Additionally push buttons for preset function (only model characteristic SB2, SG2)

Cable pull rotary encoder with SSI interface



Function

Lighter and more solid cable pull rotary encoder with flat housing design.

Dimensions

For design 80/130

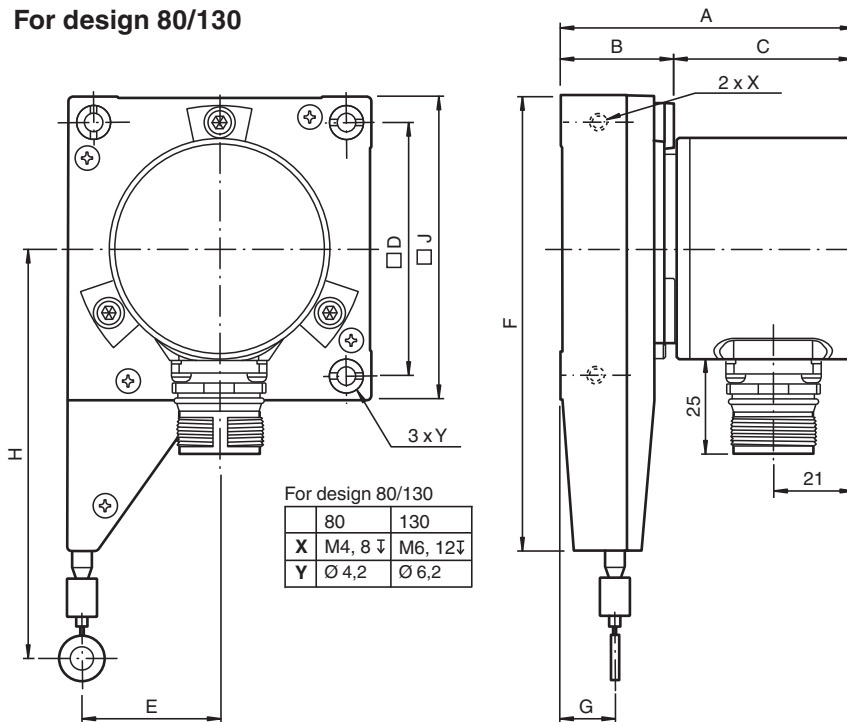

Release date: 2022-12-12 Date of issue: 2022-12-12 Filename: t176924_eng.pdf

Dimensions

For design 190

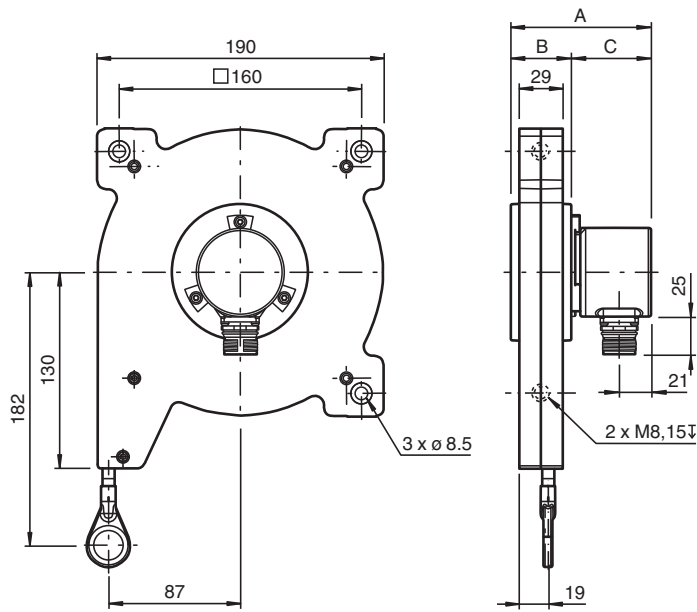

Connections
Dimensions in mm

Cable

Connector M12

Connector M23

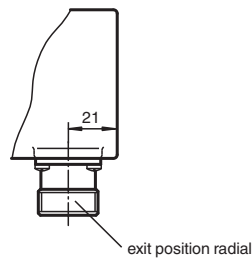
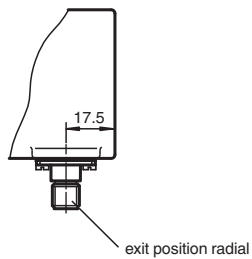
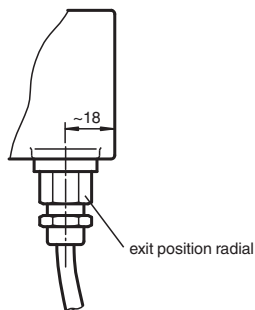

Release date: 2022-12-12 Date of issue: 2022-12-12 Filename: t176924_eng.pdf

Dimensions

Cable mounts

A Brass ring PE

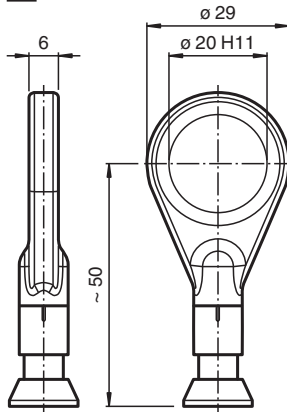

B Ring

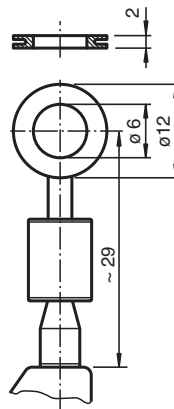

C Ball joint

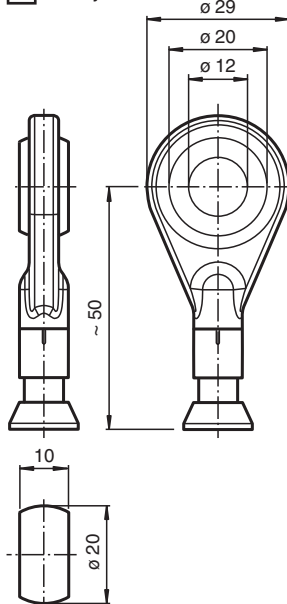

Technical Data

General specifications

Detection type	magnetic sampling	
Device type	Target line with SSI interface	
Measuring range	3000 ... 10000 mm	
Construction type	80 mm, 130 mm, 190 mm	
Resolution	Cable pull: design 80 mm: with 13 Bit 0,028 mm; with 12 Bit 0,056 mm design 130 mm: with 13 Bit 0,047 mm; with 12 Bit 0,094 mm design 190 mm: with 13 Bit 0,068 mm; with 12 Bit 0,0135 mm Encoder: standard 25 Bit (13 Bit/revolution) or as an option 24 Bit (12 Bit/revolution)	

Electrical specifications

Operating voltage	U_B	4.75 ... 30 V DC
No-load supply current	I_0	typ. 50 mA
Power consumption	P_0	approx. 1.5 W
Output code	Gray code, binary code	
Code course (counting direction)	adjustable	

Release date: 2022-12-12 Date of issue: 2022-12-12 Filename: t176924_eng.pdf

Technical Data

Interface	
Interface type	SSI
Transfer rate	0.1 ... 2 MBit/s
Cycle time	< 100 µs
Standard conformity	RS 422
Input 1	
Input type	Selection of counting direction (cw/ccw)
Signal voltage	
High	4.75 V ... U_B (cw descending)
Low	0 ... 2 V or unconnected (cw ascending)
Input current	< 6 mA
Input 2	
Input type	zero-set (PRESET 1) with falling edge
Signal voltage	
High	4.75 V ... U_B
Signal duration	min. 1.1 s
Connection	
Connector	M12 connector, 8-pin or M23 connector, 12-pin
Cable	Ø7 mm, 6 x 2 x 0.14 mm ²
Standard conformity	
Degree of protection	acc. DIN EN 60529
Connection side	cable models: IP65 connector models: IP65 Cable pull: IP50
Climatic testing	DIN EN 60068-2-3, no moisture condensation
Emitted interference	EN 61000-6-4:2007
Noise immunity	EN 61000-6-2:2005
Ambient conditions	
Ambient temperature	-30 ... 70 °C (-22 ... 158 °F)
Operating temperature	-30 ... 70 °C (-22 ... 158 °F)
Storage temperature	-30 ... 70 °C (-22 ... 158 °F)
Relative humidity	98 % , no moisture condensation
Mechanical specifications	
Rope diameter	0.55 mm
Material	
Housing	nickel-plated steel
Cable pull	design 80/130 : Luranyl [®] or Lexan 920 design 190 : ABS-GF17
Flange	Aluminum
Rope	Stainless steel 1.4401/316
Life span	up to 10 ⁶ Cycles

Connection

Signal	Cable, 12-core	Connector M12, 8-pin	Connector M23, 12-pin, cw	Connector M23, 12-pin, ccw	Explanation
GND (encoder)	White	1	1	1	Power supply
U _b (encoder)	Brown	2	2	8	Power supply
Clock (+)	Green	3	3	3	Positive cycle line
Clock (-)	Yellow	4	4	11	Negative cycle line
Data (+)	Grey	5	5	2	Positive transmission data
Data (-)	Pink	6	6	10	Negative transmission data
Reserved	Black		7	12	Not wired, reserved
V/R	Red	8	8	5	Input for selection of counting direction
PRESET 1	Blue	7	9	9	zero-setting input
Reserved	Violet		10	4	Not wired, reserved
Reserved	Grey/Pink		11	6	Not wired, reserved
Reserved	Red/Blue		12	7	Not wired, reserved

--	--	--	--

Interface

Description

The Synchronous Serial Interface was specially developed for transferring the output data of an absolute encoder to a control device. The control module sends a clock bundle and the absolute encoder responds with the position value. Thus only 4 lines are required for the clock and data, no matter what the resolution of the rotary encoder is. The RS 422 interface is optically isolated from the power supply.

SSI signal course Standard

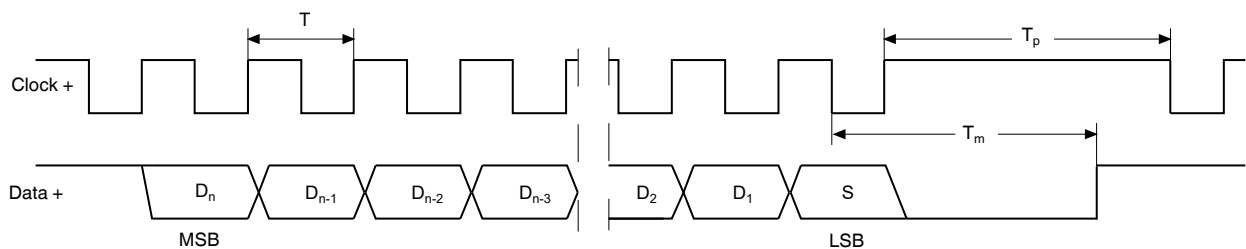

- D₁, ..., D_n: Position data
- S: Special bit
- MSB: Most significant bit
- LSB: Least significant bit
- T = 1/f: Duration of period of clock signal ≤ 1 MHz
- T_m: Monoflop time 20 μs ± 1 μs
- T_p: Clock pause ≥ monoflop time (T_p ≥ T_m)

SSI output format Standard

- At idle status signal lines "Data +" and "Clock +" are at high level (5 V).
- The first time the clock signal switches from high to low, the data transfer in which the current information (position data (D_n) and special bit (S)) is stored in the encoder is introduced.±
- The highest order bit (MSB) is applied to the serial data output of the encoder with the first rising pulse edge.
- The next successive lower order bit is transferred with each following rising pulse edge.
- After the lowest order bit (LSB) has been transferred the data line switches to low until the monoflop time T_m has expired.
- No subsequent data transfer can be started until the data line switches to high again or the time for the clock pause T_p has expired.
- After the clock sequence is complete, the monoflop time T_m is triggered with the last falling pulse edge.

Release date: 2022-12-12 Date of issue: 2022-12-12 Filename: t176924_eng.pdf

- The monoflop time T_m determines the lowest transmission frequency.

SSI output format ring slide operation (multiple transmission)

- In ring slide operation, multiple transmission of the same data word over the SSI interface makes it possible to offer the possibility of detecting transmission errors.
- In multiple transmission, n bits are transferred per data word in standard format. The value n equals the total resolution of the encoder.
As an example: a multiturn encoder with a resolution of 8192 steps/revolution (13 bit) and a max. number of 4096 revolutions (12 bit) has a total resolution of $n = 25$ bit.
- If the clock change is not interrupted after the last falling pulse edge, ring slide operation automatically becomes active. This means that the information that was stored at the time of the first clock change is generated again.
- After the first position transmission, the n+1 pulse controls data repetition. If the n+1 pulse follows after an amount of time greater than the monoflop time T_m , a new current data word will be transmitted with the following pulses.



If the pulse line is exchanged, the data word is generated offset.

Block diagram

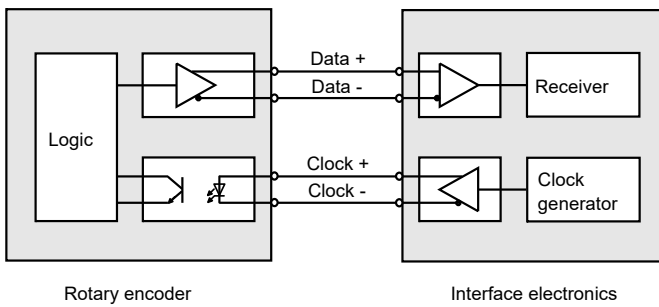

Line length

Line length in m	Baudrate in kHz
< 50	< 400
< 100	< 300
< 200	< 200
< 400	< 100

Parameterization

Push buttons on encoder with model characteristic SB2, SG2

In addition to the electrical preset function (PRESET 1) these models are equipped with 2 push buttons for manually setting the zero point of the rotary encoder.

Manually zero set

1. Simultaneously press and hold the push buttons A and B for 2 s.

After releasing the push buttons the rotary encoder sets the current position as zero point.

Dimensions

Variable Data and Dimensions

Technical data	Design 80	Design 130	Design 190
Measuring length (in m)	03	05	10
Drum size (incl. cable) (in mm)	230	385	555
Retraction speed (in m/s)	6	3	4
Spring retraction force (in N)	5-6.3	4.5-7	9-12
Weight (in kg)	0.55	1.1	2.2
Rotary encoder Ø (in mm)	58		
Dimensions (in mm)			
A	78	80	93
B	30	32	40
C	48	48	53

Release date: 2022-12-12 Date of issue: 2022-12-12 Filename: t176924_eng.pdf

D	67	110	-
E	36	61	-
F	120	186	-
G	14.5	17	-
H	106	150	-
J	80	130	-

Type Code

Model Number



Option (Resolution)

- NN** 13 Bit Singleturn (Standard)
- 12** 12 Bit single turn

Electrical connection

- C1** Cable, 1 m
- C2** Cable, 2 m
- C3** Cable, 5m
- CA** Cable, 10 m
- AA** M23 device plug, cw
- AB** M23 device plug, ccw
- BE** M12 device plug, 8-pin

Electrical interface

- SB1** UB = 4,75 V ... 30 V, SSI binary
- SG1** UB = 4,75 V ... 30 V, SSI Gray
- SB2** UB = 4,75 V ... 30 V, SSI binary, with push buttons
- SG2** UB = 4,75 V ... 30 V, SSI Gray, with push buttons

Cable mounts

- A** Ring PE carrier (with 10 m only)
- B** Eyelet
- C** Ball joint (with 10 m only)

Length of measuring cable

- 03** 3 m
- 05** 5 m
- 10** 10 m

Release date: 2022-12-12 Date of issue: 2022-12-12 Filename: t176924_eng.pdf