

Multi-Input/Output

FieldConnex® Fieldbus

F2D0-MIO-Ex12.FF.*

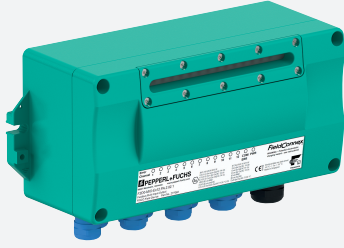

- For discrete inputs and outputs
- Aluminum cast iron, IP66
- Configurable cable entries for bus lines and field signal lines
- International approvals
- For FOUNDATION Fieldbus H1
- Installation in Zone 1/Div. 1, intrinsically safe
- Sensors in Zone 0/Div. 1
- Monitors sensor condition
- Removable terminals
- Power, Com, Diagnostics, and Error LEDs
- Test points for easy troubleshooting

Multi-input/output for digital signals, stand-alone device with aluminum housing for field installation



Function

This fieldbus junction box holds a multi-input/output (MIO) for transferring signals from discrete inputs and valves to the control system. The MIO offers the same functionality as the components FD0-VC-Ex* and FD0-BI-*. The fieldbus junction box can be installed in Zone 1/Div. 1 with sensors and actuators located in Zone 0/Div. 1. The housing, type F2, is made of sturdy cast aluminum for installation in rough environments. Fieldbus and field device entrances can be selected individually from a range of cable glands. Optionally, either screw terminals or spring terminals can be chosen.

Connection

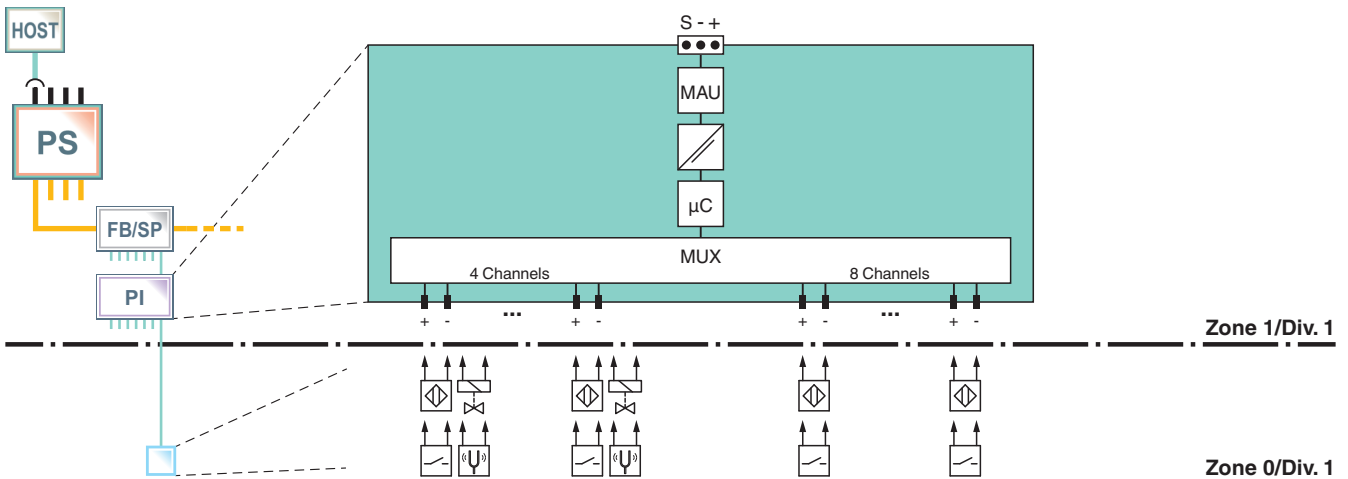

Technical Data

General specifications	
Design / Mounting	Outside installation
Installation in hazardous area	Zone 1 / Div. 1
Electronic component	Binary multi-input/output R8D0-MIO-Ex12.FF* For technical data on installed electronic component see datasheet.
Fieldbus connection	
Fieldbus type	FOUNDATION Fieldbus
Digital input	
Number of inputs	12

Release date: 2024-11-27 Date of issue: 2024-11-27 Filename: t179190_eng.pdf

Technical Data

Galvanic isolation	
Foundation Fieldbus/Field circuit	safe galvanic isolation acc. to EN 60079-11, voltage peak value 375 V
Directive conformity	
Electromagnetic compatibility	
Directive 2014/30/EU	EN 61326-1:2013
Low voltage	
Directive 2014/35/EU	EN 61010-1:2010
Standard conformity	
Galvanic isolation	EN 60079-11
Electromagnetic compatibility	NE 21:2011
Degree of protection	IEC 60529
Fieldbus standard	IEC 61158-2
Shock resistance	EN 60068-2-27
Vibration resistance	EN 60068-2-6
Ambient conditions	
Ambient temperature	-40 ... 70 °C (-40 ... 158 °F) hazardous area
Storage temperature	-40 ... 85 °C (-40 ... 185 °F)
Relative humidity	≤ 95 % non-condensing
Shock resistance	15 g , 11 ms
Vibration resistance	10 g , 10 ... 150 Hz
Corrosion resistance	acc. to ISA-S71.04-1985, severity level G3
Mechanical specifications	
Connection type	plug-in terminals , spring terminal and screw terminal
Core cross section	
Bus	up to 2.5 mm ²
Inputs	up to 2.5 mm ²
Cable diameter	see table 2
Cable gland	sensor inputs M16, fieldbus M20
Housing material	Aluminum
Degree of protection	IP66
Mass	1800 g
Mounting	wall mounting
Data for application in connection with hazardous areas	
EU-type examination certificate	BVS 16 ATEX E 075 X
Marking	Ⓜ II 2 (1) G Ex ib [ia Ga] IIC T4 Gb , Ⓜ II 3 (1) G Ex ic [ia Ga] IIC T4 Gc , Ⓜ II 3 (1) G Ex ec [ia Ga] IIC T4 Gc , Ⓜ I (M1) [Ex ia Ma] I , Ⓜ II (1) D [Ex ia Da] IIIC , Ⓜ II 2 (1) D Ex tb [ia Da] IIIC T130 °C Db
Bus	FISCO see EC-Type Examination Certificate
Directive conformity	
Directive 2014/34/EU	EN 60079-0:2012 , EN 60079-7:2015 , EN 60079-11:2012 , EN 60079-31:2014
International approvals	
FM approval	pending
IECEx approval	IECEx BVS 16.0051X
Approved for	Ex ib [ia Ga] IIC T4 Gb , Ex ic [ia Ga] IIC T4 Gc , Ex ec [ia Ga] IIC T4 Gc , [Ex ia Ma] I , [Ex ia Da] IIIC , Ex tb [ia Da] IIIC T130 °C Db
Certificates and approvals	
Marine approval	pending
General information	
Supplementary information	EC-Type Examination Certificate, Statement of Conformity, Declaration of Conformity, Attestation of Conformity and instructions have to be observed where applicable. For information see www.pepperl-fuchs.com .

Type Code

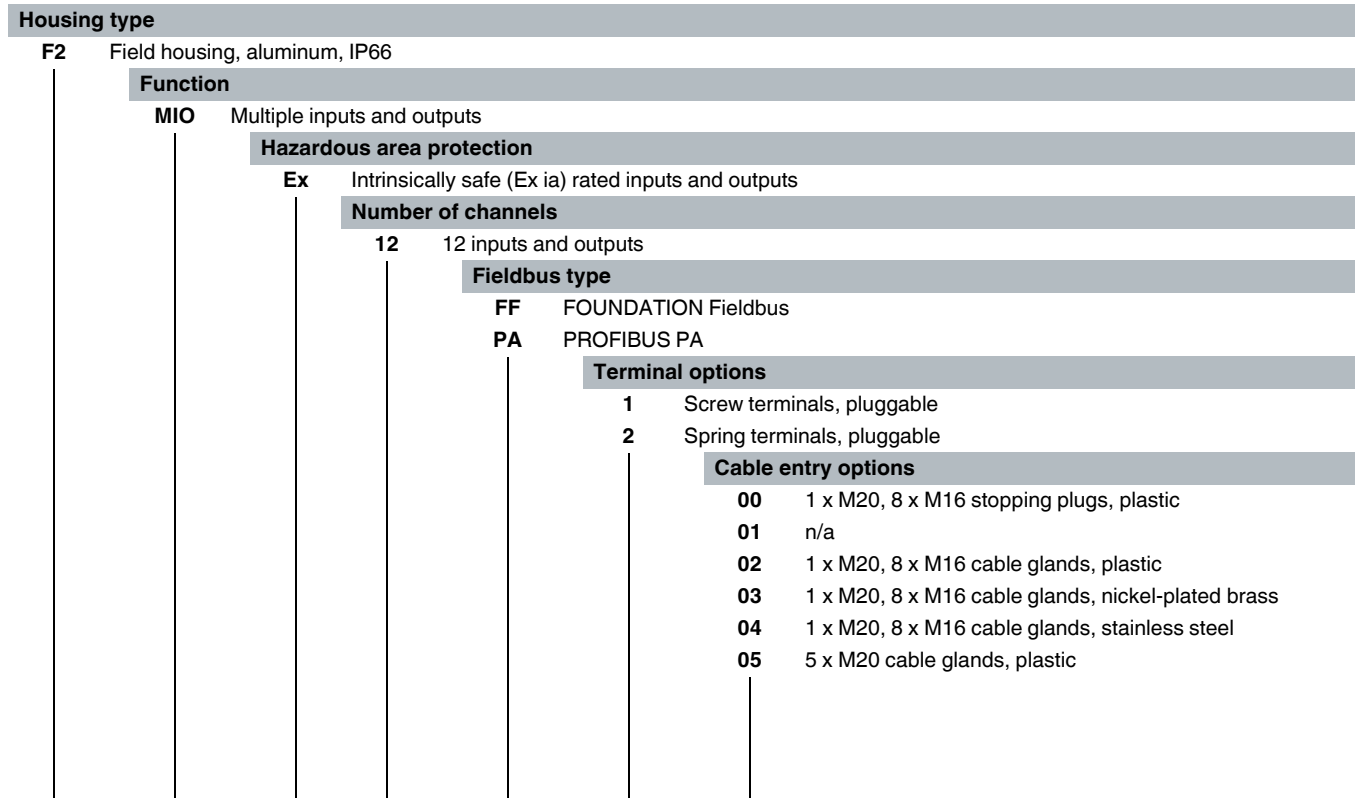

F2	-	D0-MIO	-	Ex	12
A	-	B	-	C	D	.	E	.	F

Example:

F2D0-MIO-Ex12.FF.1.02: Multi-input/output in aluminum housing with cable glands made of plastic and 12 inputs/outputs with pluggable screw terminals.

Note:

Contact your Pepperl+Fuchs representative to check the availability of individual variants.

Release date: 2024-11-27 Date of issue: 2024-11-27 Filename: t179190_eng.pdf

Overview of System Components

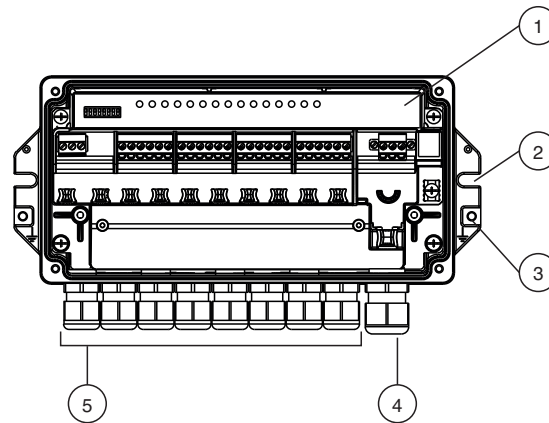

Figure 1: F2D0-MIO*

- 1 For details on the electronic unit see datasheet on R8D0-MIO-*
- 2 Notch for fixing the device housing with screw M6
- 3 Grounding point
- 4 Cable gland for fieldbus connection, fix with spanner, size see table 2, AF2
- 5 8 cable glands for up to 12 spur inputs/outputs, fix with spanner, size see table 2, AF1

Dimensions

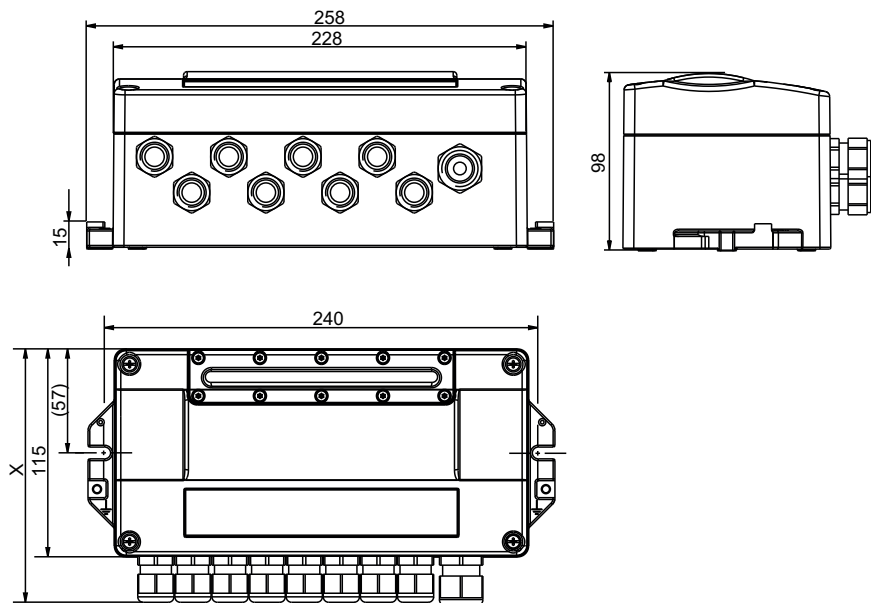

Figure 2: F2D0-MIO* All dimensions in mm without tolerance indication.

- X** Height depending on the cable connection type used, see table 1

Electrical Connection

Table 1: Variations of cable connections, housing types, and temperature ranges

Cable entry option	Type of cable connection	F2 housing, outside dimension "X" (mm)	Temperature range for use in hazardous area (°C)	Temperature range for use in safe area (°C)
00	M16 stopping plugs, plastic	121.5	-40 ... +70	-40 ... +70
01	n/a	--	--	--
02	M16 & M20 cable glands, plastic	146	-40 ... +70	-40 ... +70
03	M16 & M20 cable glands, nickel-plated brass	146	-40 ... +70	-40 ... +80
04	M16 & M20 cable glands, stainless steel	146	-40 ... +70	-40 ... +80
05	M20 cable glands, plastic	146	-40 ... +70	-40 ... +70

Table 2: Cable diameter depending on cable glands, spanner sizes

Cable entry option	CH1 ... CH12 Multiple Inputs/Outputs			Fieldbus		
	Description	Cable diameter (mm)	AF1 (mm)	Description	Cable diameter (mm)	AF2 (mm)
00	M16 stopping plug, plastic	--	19	M20, stopping plug, plastic	--	19
01	n/a	--	--	n/a	--	--
02	M16 cable gland, plastic	4 ... 8 mm	19	M20 cable gland, plastic	6 ... 12 mm	19
03	M16 cable gland, nickel-plated brass	4 ... 12 mm	22	M20 cable gland, nickel-plated brass	4 ... 12 mm	22
04	M16 cable gland, stainless steel	4 ... 12 mm	22	M20 cable gland, stainless steel	4 ... 12 mm	24
05	M20 cable gland, plastic	6 ... 12 mm	24	M20 cable gland, plastic	6 ... 12 mm	24