

Multiturn absolute rotary encoder

EVM78E-P



- Up to 30 Bit multiturn
- ATEX approval
- IECEx approval
- Flameproof enclosure
- Removable connection cap



Function

Absolute multiturn rotary encoders deliver an absolute step value for each angle setting. This device has a maximum basic resolution of 65536 steps per revolution (16 bits) and codes up to 16384 revolutions (14 bits). Thus the overall resolution amounts to 30 bits. On account of the high number of measuring steps resulting (more than 1 billion), this type of encoder can be used to divide very long linear distances into small measuring steps. The device is designed for shaft assembly and is available in servo flange or clamping flange design.

Dimensions

Encoder length L

Version		Length L
Radial cable exit	Clamping flange	134 mm
	Servo flange	134 mm
Axial cable exit	Clamping flange	150 mm
	Servo flange	150 mm

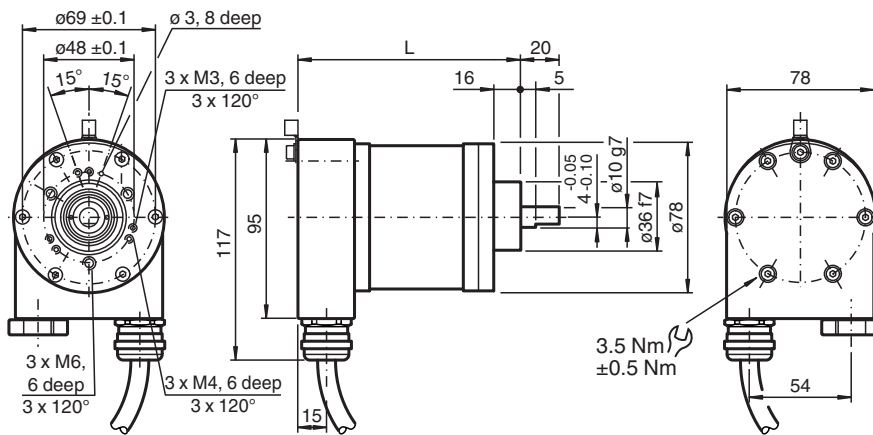

Clamping flange, cable exit radial

Release date: 2024-08-09 Date of issue: 2024-08-09 Filename: t179900_eng.pdf

Dimensions

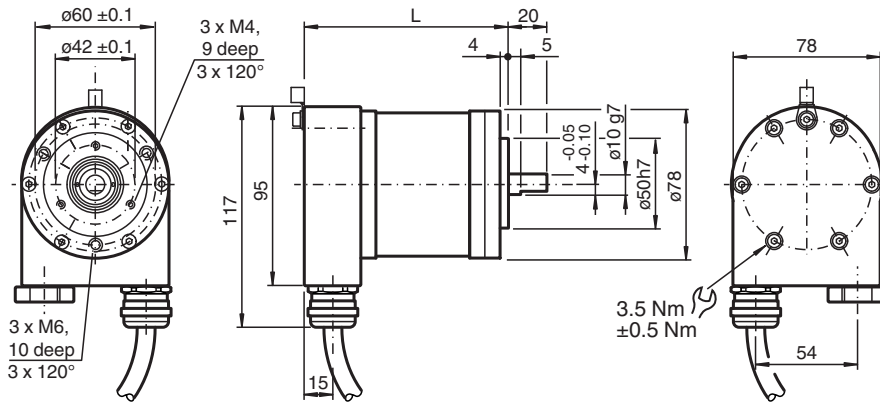

Servo flange, radial cable exit

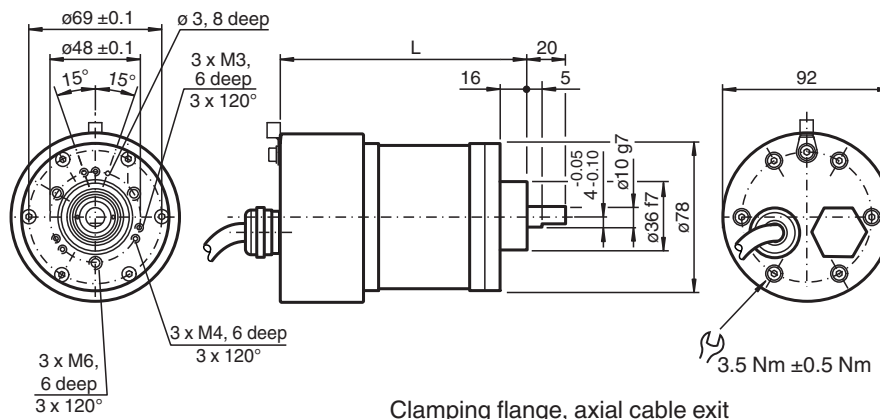

Clamping flange, axial cable exit

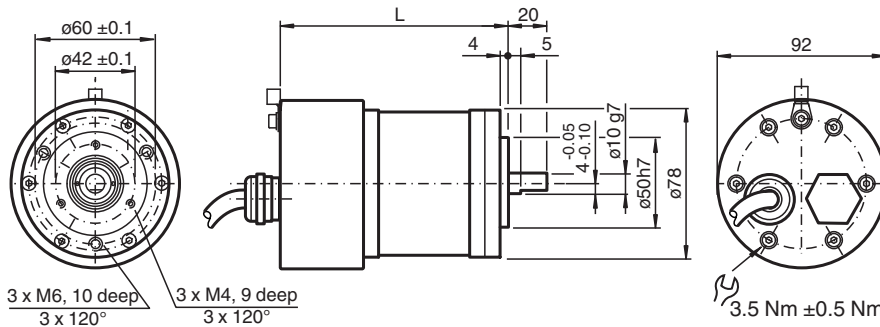

Servo flange, axial cable exit

Shaft 12 mm

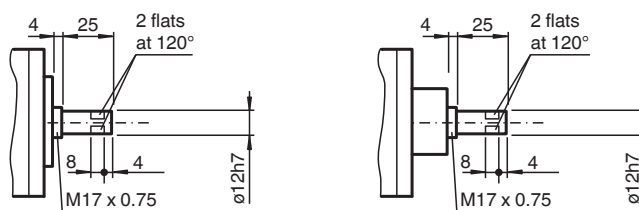

Release date: 2024-08-09 Date of issue: 2024-08-09 Filename: t179900_eng.pdf

Technical Data

General specifications

Technical Data

Detection type	photoelectric sampling	
Device type	Multiturn absolute rotary encoder	
Functional safety related parameters		
MTTF _d	180 a	
L ₁₀	7.7 E+9 at 3000 rpm	
Electrical specifications		
Operating voltage	U _B	10 ... 30 V DC
No-load supply current	I ₀	max. 270 mA at 10 V DC max. 115 mA at 24 V DC
Time delay before availability	t _v	< 250 ms
Linearity	± 2 LSB at 16 Bit, ± 1 LSB at 13 Bit	
Output code	binary code	
Code course (counting direction)	programmable, cw ascending (clockwise rotation, code course ascending) cw descending (clockwise rotation, code course descending)	
Interface		
Interface type	PROFINET	
Resolution		
Single turn	up to 16 Bit	
Multiturn	up to 14 Bit	
Overall resolution	up to 30 Bit	
Transfer rate	100 MBit/s	
Cycle time	≤ 1 ms (IRT) , ≤ 10 ms (RT)	
Connection		
Terminal compartment	see ordering information	
Standard conformity		
Degree of protection	DIN EN 60529, IP66	
Climatic testing	DIN EN 60068-2-78 , no moisture condensation	
Emitted interference	EN 61000-6-4:2007/A1:2011	
Noise immunity	EN 61000-6-2:2005	
Shock resistance	DIN EN 60068-2-27, 100 g, 3 ms	
Vibration resistance	DIN EN 60068-2-6, 10 g, 10 ... 2000 Hz	
Approvals and certificates		
IECEX approval		
Equipment protection level Gb	IECEX ITS 15.0061X	
ATEX approval		
Equipment protection level Gb	ITS 15 ATEX 18372X	
Ambient conditions		
Operating temperature	-40 ... 70 °C (-40 ... 158 °F)	
Storage temperature	-40 ... 85 °C (-40 ... 185 °F)	
Mechanical specifications		
Material		
Combination 1	housing: anodized aluminum flange: anodized aluminum shaft: Stainless steel 1.4404 / AISI 316L	
Combination 2 (Inox)	housing: Stainless steel 1.4404 / AISI 316L flange: Stainless steel 1.4404 / AISI 316L shaft: Stainless steel 1.4404 / AISI 316L	
Mass	approx. 2600 g (combination 1) approx. 3900 g (combination 2)	
Rotational speed	max. 3000 min ⁻¹	
Moment of inertia	180 gcm ²	
Starting torque	≤ 4 Ncm	
Shaft load		
Axial	60 N	
Radial	80 N	

Technical Data

General information

Use in the hazardous area

see instruction manuals

Type Code

Structure of the type code

E	V	M	7	8	P	-	(1)	(1)	(2)	(3)	(3)	(4)	P	B	(5)	-	(6)	(6)	(7)	(7)
---	---	---	---	---	---	---	-----	-----	-----	-----	-----	-----	---	---	-----	---	-----	-----	-----	-----

E	Data format
E	Ethernet

V	Shaft version
V	Solid shaft

M	Funktional principle
M	Multiturn

78	Size
78	Housing diameter 78 mm

E	Option 1
E	Explosion Proof, Standard IP66

(1) (1)	Shaft diameter
01	Shaft Ø 10 mm x 20 mm
02	Shaft Ø 12 mm x 25 mm

(2)	Flange
1	Clamping flange
2	Servo flange

(3) (3)	Connection type
00	Terminal compartment with two M20 x 1.5 6H threads each, 17 mm thread depth, for cable glands
DR	Terminal compartment, 2 cable glands
KR	Terminal compartment, 1 cable gland, 1 stopping plug

(4)	Exit position
A	Axial
R	Radial

P	Option
P	Profinet

B	Output Code
B	Binary

(5)	Housing material
N	Aluminum
I	INOX 1.4404 (AISI 316L)

(6) (6)	Multiturn: Number of bits and puls count
12	12 Bits, 4096 pulses
14	14 Bits, 16384 pulses

(7) (7)	Singleturn: Number of bits and puls count
13	13 Bits, 8192 Impulse
16	16 Bits, 65536 Impulse

Connection

Signal	Terminal compartment
Ground wire	Grounding terminal
GND (rotary encoder)	1
+U _b (rotary encoder)	2
Not connected	3
Not connected	4
Rx-	5
Tx-	6
Rx+	7
Tx+	8

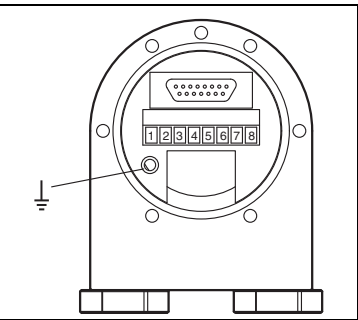

Installation

Anti-interference measures

The use of highly sophisticated microelectronics requires a consistently implemented anti-interference and wiring concept. This becomes all the more important the more compact the constructions are and the higher the demands are on the performance of modern machines.

The following installation instructions and proposals apply for "normal industrial environments". There is no ideal solution for all interfering environments.

When the following measures are applied, the encoder should be in perfect working order:

- Termination of the serial line with a 120 Ω resistor (between Receive/Transmit and Receive/Transmit) at the beginning and end of the serial line (e. g. the control and the last encoder).
- The wiring of the encoder should be laid at a large distance to energy lines which could cause interferences.
- Cable cross-section of the screen at least 4 mm².
- Cable cross-section at least 0,14 mm².
- The wiring of the screen and 0 V should be arranged radially, if and when possible.
- Do not kink or jam the cables.
- Adhere to the minimum bending radius as given in the data sheet and avoid tensile as well as shearing load.

Operating instructions

Every encoder manufactured by Pepperl+Fuchs leaves the factory in a perfect condition. In order to ensure this quality as well as a faultless operation, the following specifications have to be taken into consideration:

- Avoid any impact on the housing and in particular on the encoder shaft as well as the axial and radial overload of the encoder shaft.
- The accuracy and service life of the encoder is guaranteed only, if a suitable coupling is used.
- The operating voltage for the encoder and the follow-up device (e. g. control) has to be switched on and off simultaneously.
- Any wiring work has to be carried out with the system in a dead condition.
- The maximum operating voltages must not be exceeded. The devices have to be operated at extra-low safety voltage.

Notes on connecting the electric screening

The immunity to interference of a plant depends on the correct screening. In this field installation faults occur frequently. Often the screen is applied to one side only, and is then soldered to the earthing terminal with a wire, which is a valid procedure in LF engineering. However, in case of EMC the rules of HF engineering apply.

One basic goal in HF engineering is to pass the HF energy to earth at an impedance as low as possible as otherwise energy would discharge into the cable. A low impedance is achieved by a large-surface connection to metal surfaces.

The following instructions have to be observed:

- Apply the screen on both sides to a "common earth" in a large surface, if there is no risk of equipotential currents.
- The screen has to be passed behind the insulation and has to be clamped on a large surface below the tension relief.
- In case of cable connections to screw-type terminals, the tension relief has to be connected to an earthed surface.
- If plugs are used, metallised plugs only should be fitted (such as sub D plugs with metallised housing). Please observe the direct connection of the tension relief to the housing.

Advantage:	metallised connector, shield
relief	clamped with the strain clamp

Disadvantage: soldering shield on

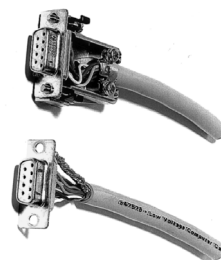

Safety instructions

Please observe the national safety and accident prevention regulations as well as the subsequent safety instructions in these operating instructions when working on encoders.

If failures cannot be remedied, the device has to be shut down and has to be secured against accidental operation. Repairs may be carried out only by the manufacturer. Entry into and modifications of the device are not permissible.

Tighten the clamping ring only, if a shaft has been fitted in the area of the clamping ring (hollow shaft encoders). Tighten all screws and plug connectors prior to operating the encoder.

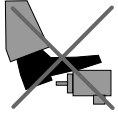

Do not stand on the encoder!

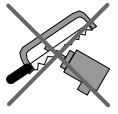

Do not remachine the drive shaft!



Avoid impact!



Do not remachine the housing!