

Cable pull rotary encoder

ECA30PL - SSI

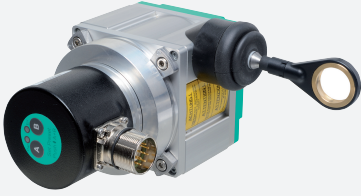

- Robust aluminum drum housing
- Drum travel when cable retracted using threaded spindle
- Bellows with steel tip
- Comprehensive accessories
- Housing can be coated as an option (Hart Coat)
- Rust and acid-resistant measuring cable
- SSI interface
- Free of wear magnetic sampling
- Additionally push buttons for preset function (only model characteristic SB2, SG2)

Cable pull rotary encoder with SSI interface



Function

Flexible cable pull rotary encoder designed to meet tough requirements in all fields of application.

Dimensions

Details of variable specifications of designs and measuring length see chapter „Variable Data and Dimensions“

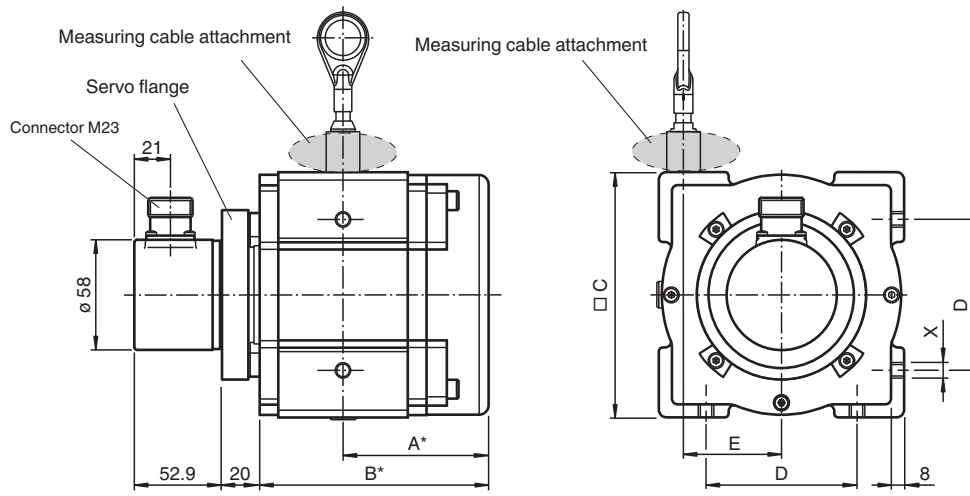

*depending on measuring length

Measuring length	X
01 - 02	4 x M6 ↓8
03	8 x M6 ↓8
05 - 10	4 x M8 ↓8
15 - 30	12 x M8 ↓8
35 - 60	12 x M10 ↓11

Release date: 2024-02-29 Date of issue: 2024-02-29 Filename: t181402_eng.pdf

Dimensions

Connections

Dimensions in mm

Cable

Connector M12

Connector M23

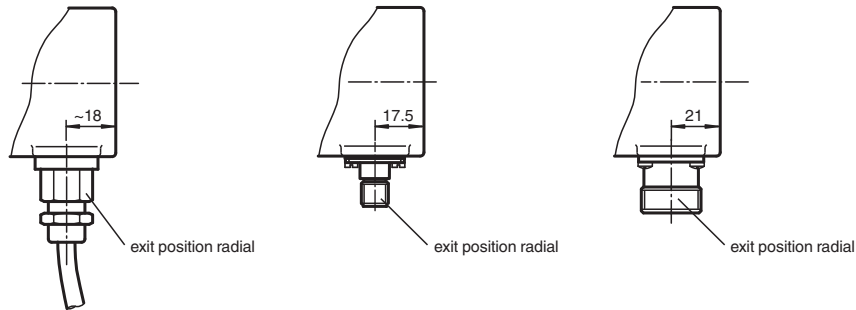

A

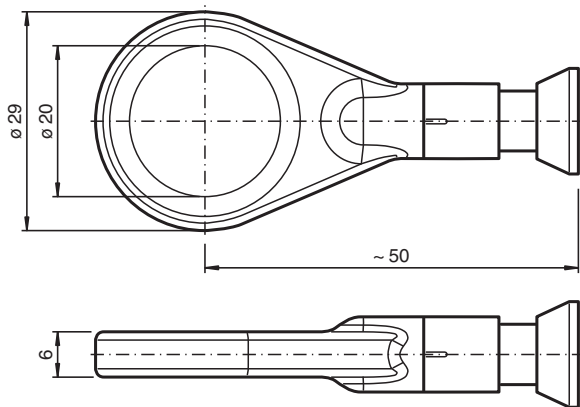

C

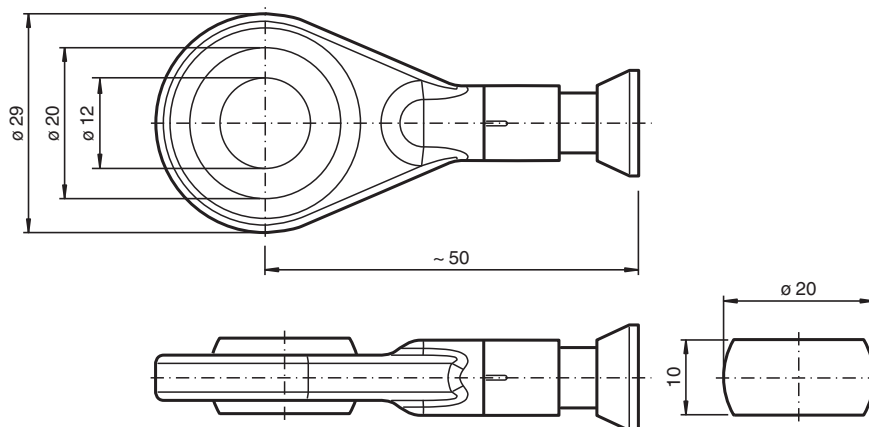

Release date: 2024-02-29 Date of issue: 2024-02-29 Filename: t181402_eng.pdf

Dimensions

1 For design 130/190

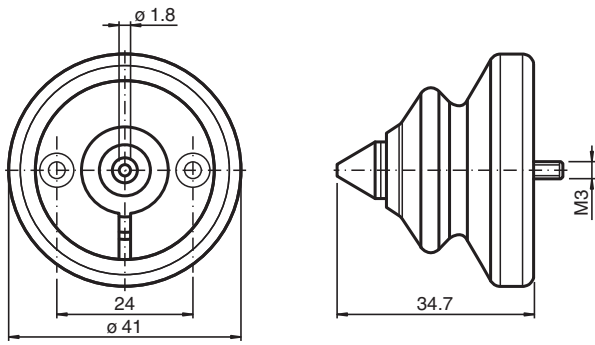

1 For design 80

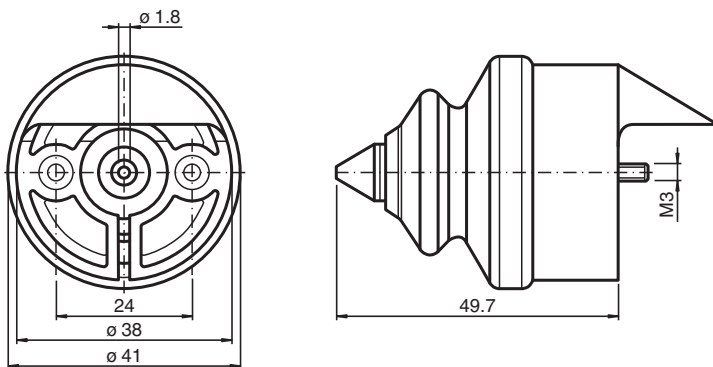

2 For design 130/190

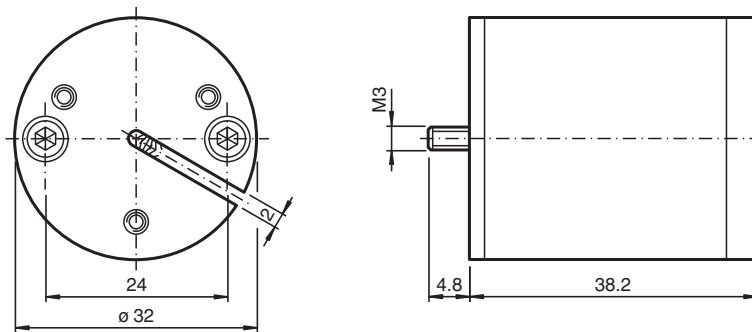

2 For design 80

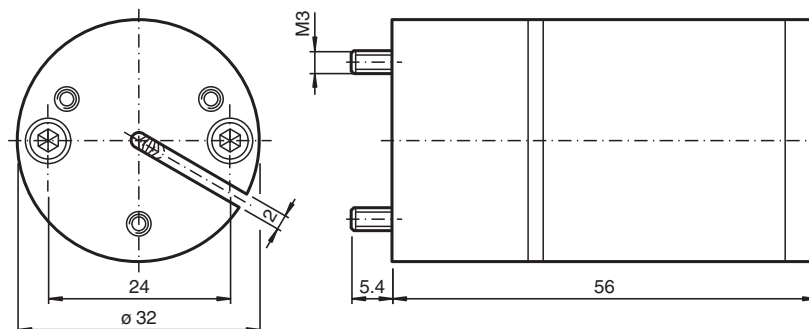

Release date: 2024-02-29 Date of issue: 2024-02-29 Filename: t181402_eng.pdf

Dimensions

4 For design 130/190

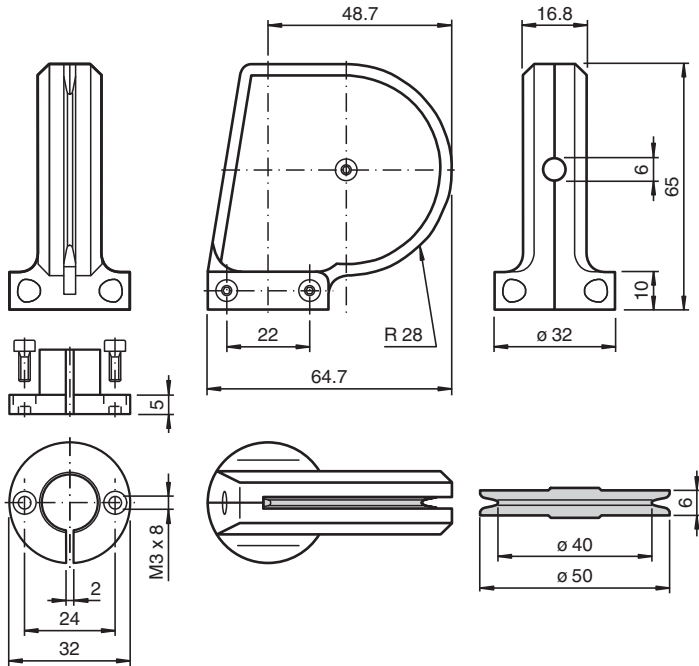

4 For design 80

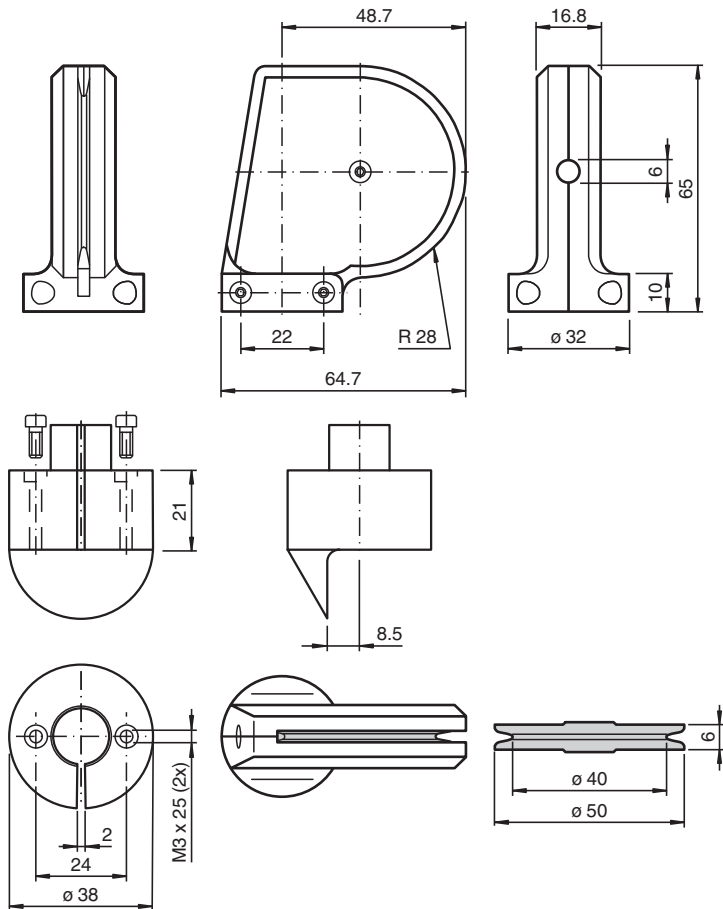

Release date: 2024-02-29 Date of issue: 2024-02-29 Filename: t181402_eng.pdf

Dimensions

5 For design 130/190

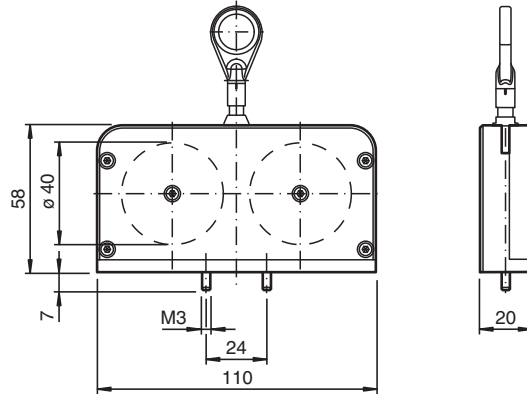

5 For design 80

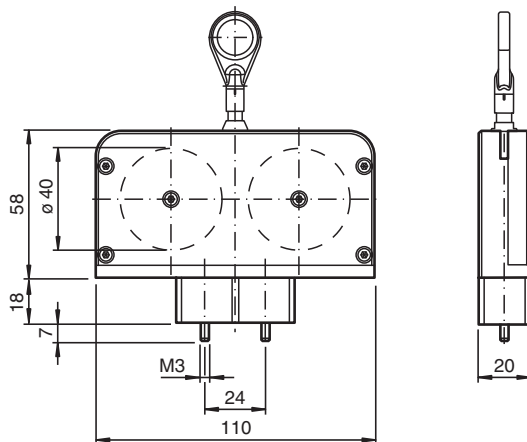

Technical Data

General specifications

Detection type	magnetic sampling	
Device type	Premium Line with SSI interface	
Measuring range	1000 ... 60000 mm	
Construction type	80 mm, 130 mm, 190 mm	
Resolution	Cable pull: Design 80 mm: 0,024 mm Design 130 mm: 0,041 mm Design 190 mm: 0,059 mm Encoder: 25 Bit (13 Bit/revolution)	

Functional safety related parameters

B _{10d}	300000
------------------	--------

Electrical specifications

Operating voltage	U _B	4.75 ... 30 V DC
No-load supply current	I ₀	typ. 50 mA
Power consumption	P ₀	approx. 1.5 W
Time delay before availability	t _v	< 450 ms
Output code	Gray code, binary code	
Code course (counting direction)	adjustable	

Interface

Interface type	SSI	
Cycle time	< 100 μs	
Standard conformity	RS 422	

Input 1

Technical Data

Input type	Selection of counting direction (cw/ccw)
Signal voltage	
High	4.75 V ... U_B (cw descending)
Low	0 ... 2 V or unconnected (cw ascending)
Input current	< 6 mA
Input 2	
Input type	zero-set (PRESET 1) with falling edge
Signal voltage	
High	4.75 V ... U_B
Low	0 ... 2 V
Input current	< 6 mA
Signal duration	min. 1.1 s
Connection	
Connector	M12 connector, 8-pin or M23 connector, 12-pin
Cable	Ø7 mm, 6 x 2 x 0.14 mm ² , 1 m (cable length, see order code)
Standard conformity	
Degree of protection	DIN EN 60529, IP65
Climatic testing	DIN EN 60068-2-3, no moisture condensation
Emitted interference	EN 61000-6-4:2007
Noise immunity	EN 61000-6-2:2005
Ambient conditions	
Ambient temperature	-30 ... 70 °C (-22 ... 158 °F)
Operating temperature	-30 ... 70 °C (-22 ... 158 °F)
Storage temperature	-30 ... 70 °C (-22 ... 158 °F)
Relative humidity	98 % , no moisture condensation
Mechanical specifications	
Rope diameter	1.35 mm
Bending radius	min. 17 mm
Breaking force	min. 1227 N
Material	
Cable pull	anodized aluminum or Aluminum with Hart Coat coating
Rotary encoder	housing: nickel-plated steel Flange: aluminum
Flange	Aluminum
Rope	Stainless steel 1.4401/316
Life span	up to 10 ⁶ Cycles

Connection

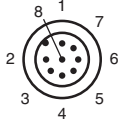
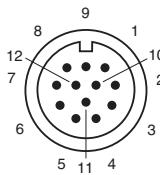
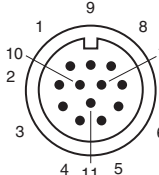
Signal	Cable, 12-core	Connector M12, 8-pin	Connector M23, 12-pin, cw	Connector M23, 12-pin, ccw	Explanation
GND (encoder)	White	1	1	1	Power supply
U _B (encoder)	Brown	2	2	8	Power supply
Clock (+)	Green	3	3	3	Positive cycle line
Clock (-)	Yellow	4	4	11	Negative cycle line
Data (+)	Grey	5	5	2	Positive transmission data
Data (-)	Pink	6	6	10	Negative transmission data
Reserved	Black		7	12	Not wired, reserved
V/R	Red	8	8	5	Input for selection of counting direction
PRESET 1	Blue	7	9	9	zero-setting input
Reserved	Violet		10	4	Not wired, reserved
Reserved	Grey/Pink		11	6	Not wired, reserved
Reserved	Red/Blue		12	7	Not wired, reserved
					

Technical Features

Variable Data and Dimensions

Technical Data	Design 80			Design 130						Design 190			
Max. measuring length (in m)	01	02	03	05	10	15	20	25	30	35	40	50	60
Drum size (incl. cable) (in mm)	200			334,1						491,5			
Retraction speed (in m/s)	8			8		6		3		4			
Spring retraction force (in N)	5-15			10-21	15-21	10-21	15-21	10-21	15-21	18-37			
Weight (in kg)	0,9	1,1	1,5	2,5	3,5	5	6	7,5	8,5	16	20	14,5	15,5
Dimensions (in mm)													
A	34	42	60	77	124	147	193	216	262	188	203	195	210
B	57	72	98	122	190	236	304	350	418	315	346	292	322
C	80			130						190			
D	50			80						140			
E	31,5			52						79			

Measuring Cable Attachments

Dimensions (in mm)		Design 80		Design 130/design 190	
Attachment		Length	Width/Ø	Length	Width/Ø
1	Bellows	49.7	41/38	34.7	41
2	Brush attachment with bellows and steel tip	90.7	32	72.9	32
4	Guide pulley	86	32	70	32
5	Double guide pulley	110	58	110	58

Release date: 2024-02-29 Date of issue: 2024-02-29 Filename: t181402_eng.pdf

		Design 80/130/190	
		Length	
8	Brush attachment + guide pulley	126	108.2

Interface

Description

The Synchronous Serial Interface was specially developed for transferring the output data of an absolute encoder to a control device. The control module sends a clock bundle and the absolute encoder responds with the position value. Thus only 4 lines are required for the clock and data, no matter what the resolution of the rotary encoder is. The RS 422 interface is optically isolated from the power supply.

SSI signal course Standard

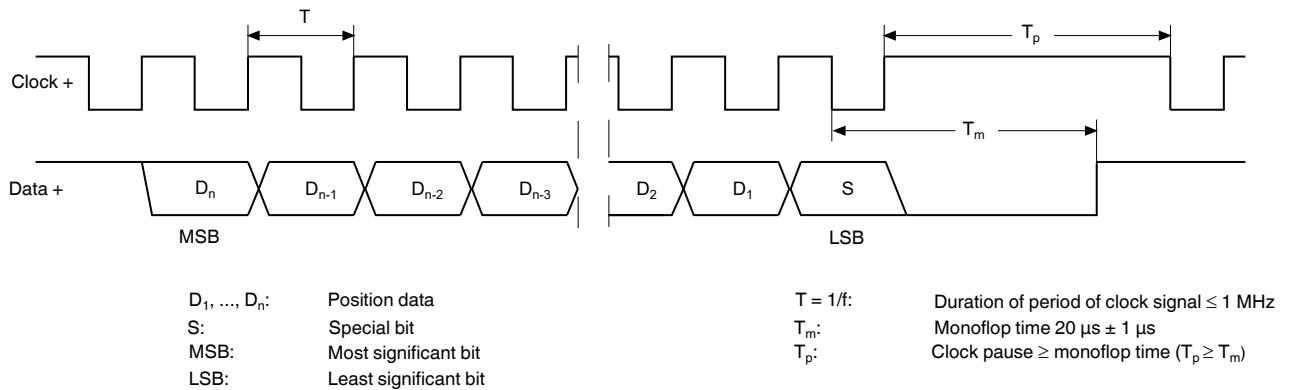

SSI output format Standard

- At idle status signal lines "Data +" and "Clock +" are at high level (5 V).
- The first time the clock signal switches from high to low, the data transfer in which the current information (position data (D_n) and special bit (S)) is stored in the encoder is introduced.
- The highest order bit (MSB) is applied to the serial data output of the encoder with the first rising pulse edge.
- The next successive lower order bit is transferred with each following rising pulse edge.
- After the lowest order bit (LSB) has been transferred the data line switches to low until the monoflop time T_m has expired.
- No subsequent data transfer can be started until the data line switches to high again or the time for the clock pause T_p has expired.
- After the clock sequence is complete, the monoflop time T_m is triggered with the last falling pulse edge.
- The monoflop time T_m determines the lowest transmission frequency.

SSI output format ring slide operation (multiple transmission)

- In ring slide operation, multiple transmission of the same data word over the SSI interface makes it possible to offer the possibility of detecting transmission errors.
- In multiple transmission, n bits are transferred per data word in standard format. The value n equals the total resolution of the encoder.
As an example: a multiturn encoder with a resolution of 8192 steps/revolution (13 bit) and a max. number of 4096 revolutions (12 bit) has a total resolution of n = 25 bit.
- If the clock change is not interrupted after the last falling pulse edge, ring slide operation automatically becomes active. This means that the information that was stored at the time of the first clock change is generated again.
- After the first position transmission, the n+1 pulse controls data repetition. If the n+1 pulse follows after an amount of time greater than the monoflop time T_m, a new current data word will be transmitted with the following pulses.



If the pulse line is exchanged, the data word is generated offset.

Block diagram

Line length

Release date: 2024-02-29 Date of issue: 2024-02-29 Filename: 1181402_eng.pdf

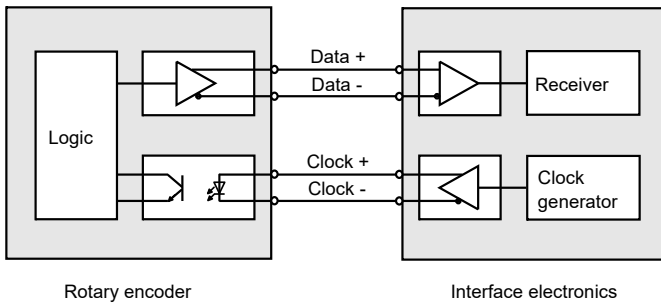

Line length in m	Baudrate in kHz
< 50	< 400
< 100	< 300
< 200	< 200
< 400	< 100

Parameterization

Push buttons on encoder with model characteristic SB2, SG2

In addition to the electrical preset function (PRESET 1) these models are equipped with 2 push buttons for manually setting the zero point of the rotary encoder.

Manually zero set

1. Simultaneously press and hold the push buttons A and B for 2 s.

After releasing the push buttons the rotary encoder sets the current position as zero point.

Type Code

Model Number



Connection type

- C1** Cable, 1 m
- C2** Cable, 2 m
- C5** Cable, 5 m
- CA** Cable, 10 m
- AA** M23 device plug, cw
- AB** M23 device plug, ccw
- BE** M12 device plug, 8-pin

Electrical interface

- SG1** SSI Gray
- SB1** SSI binary
- SG2** SSI Gray, with push buttons
- SB2** SSI binary, with push buttons

Material

- A** STD anodized aluminum
- H** Aluminum, Hart Coat coating

Attachment

- 1** Bellows with steel tip
- 2** Brush attachment with bellows and steel tip
- 4** Guide pulley
- 5** Double guide pulley
- 8** 2+4

Cable mounts

- A** Ring PE carrier
- C** Ball joint

Length of measuring cable

01-60 See table "Variable Data and Dimensions"

Release date: 2024-02-29 Date of issue: 2024-02-29 Filename: t181402_eng.pdf