



Multitrans absolute rotary encoder PSM78E

- Up to 30 Bit multitrans
- ATEX approval
- IECEx approval
- Flameproof enclosure
- Removable connection cap



Function

This series of PROFIBUS rotary encoders is based on the modern fast technology of singleturn sampling and the mechanical gear box of the multitrans unit. The absolute encoder corresponds to the PROFIBUS profile for encoders, order no. 3.062. Operation is supported based on Class 1 and Class 2.

For operation based on Class 1, position data and diagnostic data bytes 1 ... 16 are available. In addition, the direction of the code can be selected as either cw ascending (clockwise rotation, code course ascending) or cw descending (clockwise rotation, code course descending).

If the rotary encoder is operated according to Class 2, additional functions to those from Class 1 are available. These include scaling of the resolution per revolution and the overall resolution, as well as the preset function. In addition, expanded diagnostic reporting is supported.

Besides, the rotary encoder offers extended functionalities such as speed transfer, extended scaling functions, programmable limit switches and a commissioning mode.

The removable connecting hood contains a slide switch for setting the terminating resistor and the rotary switches for setting the address. Assign a fixed address and bus termination to the encoder with this switches.

The device is designed for mounting on shaft diameter 14 mm or 16 mm.

Dimensions

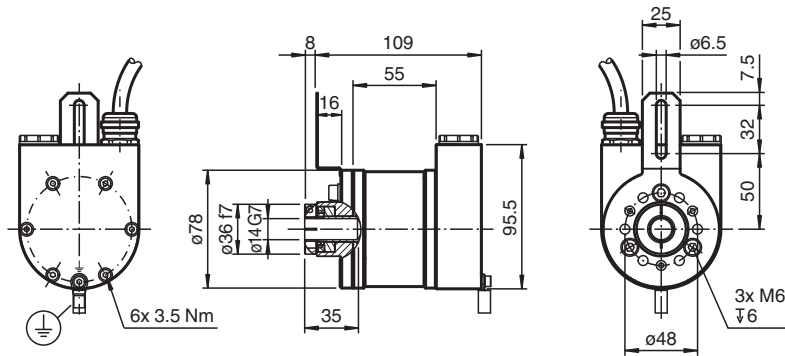

Release date: 2024-10-28 Date of issue: 2024-10-28 Filename: t183642_eng.pdf

Dimensions

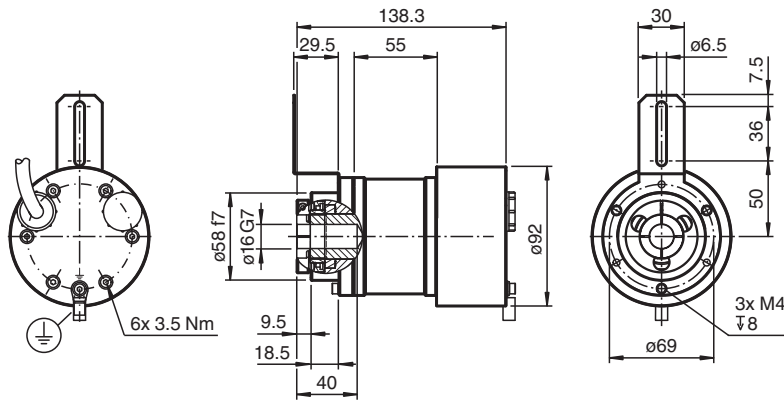
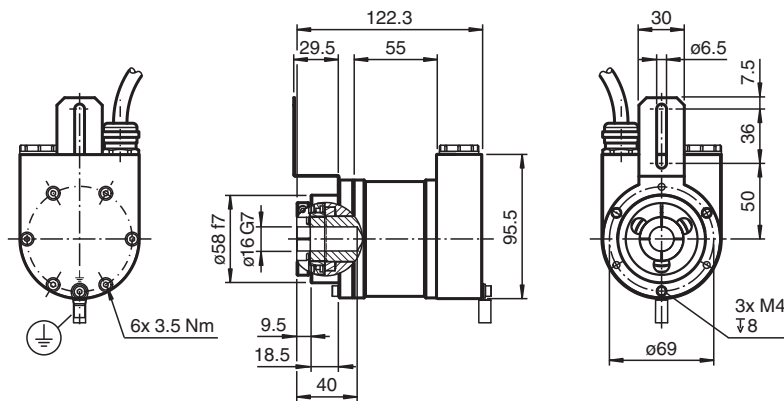
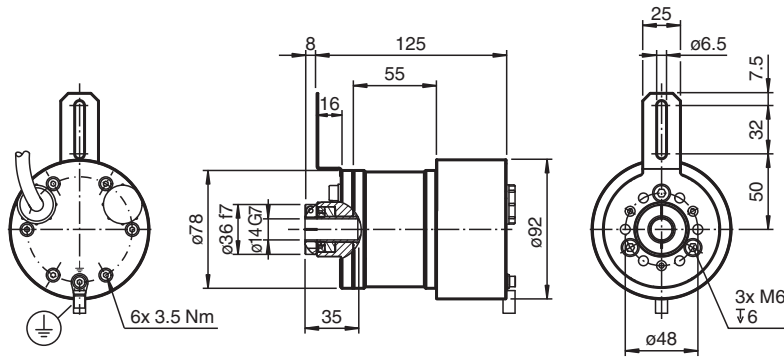

Release date: 2024-10-28 Date of issue: 2024-10-28 Filename: t183642_eng.pdf

Technical Data

General specifications		
Detection type	photoelectric sampling	
Device type	Multiturn absolute rotary encoder	
Functional safety related parameters		
MTTF _d	210 a	
L ₁₀	7.7 E+9 at 3000 rpm	
Electrical specifications		
Operating voltage	U _B	10 ... 30 V DC

Technical Data

No-load supply current	I_0	max. 230 mA at 10 V DC max. 100 mA at 24 V DC
Time delay before availability	t_v	< 1000 ms
Linearity		± 2 LSB at 16 Bit, ± 1 LSB at 13 Bit, $\pm 0,5$ LSB at 12 Bit
Output code		binary code
Code course (counting direction)		programmable, cw ascending (clockwise rotation, code course ascending) cw descending (clockwise rotation, code course descending)
Interface		
Interface type		PROFIBUS DP
Resolution		
Single turn		up to 16 Bit
Multiturn		up to 14 Bit
Overall resolution		up to 30 Bit
Transfer rate		0.0096 ... 12 MBit/s
Standard conformity		PNO profile 3.062, RS-485
Connection		
Cable		$\varnothing 9.6$ mm, 7-core
Terminal compartment		see ordering information
Standard conformity		
Degree of protection		DIN EN 60529, IP66
Climatic testing		DIN EN 60068-2-78 , no moisture condensation
Emitted interference		EN 61000-6-4:2007/A1:2011
Noise immunity		EN 61000-6-2:2005
Shock resistance		DIN EN 60068-2-27, 100 g, 3 ms
Vibration resistance		DIN EN 60068-2-6, 10 g, 10 ... 2000 Hz
Approvals and certificates		
IECEX approval		
Equipment protection level Gb		IECEX ITS 15.0061X
ATEX approval		
Equipment protection level Gb		ITS 15 ATEX 18372X
Ambient conditions		
Operating temperature		-40 ... 70 °C (-40 ... 158 °F)
Storage temperature		-40 ... 85 °C (-40 ... 185 °F)
Mechanical specifications		
Material		
Combination 1		housing: anodized aluminum flange: anodized aluminum shaft: Stainless steel 1.4404 / AISI 316L
Combination 2 (Inox)		housing: Stainless steel 1.4404 / AISI 316L flange: Stainless steel 1.4404 / AISI 316L shaft: Stainless steel 1.4404 / AISI 316L
Mass		approx. 2600 g (combination 1) approx. 3900 g (combination 2)
Rotational speed		max. 3000 min ⁻¹
Moment of inertia		180 gcm ²
Starting torque		≤ 4 Ncm
Shaft load		
Axial		60 N
Radial		80 N
General information		
Use in the hazardous area		see instruction manuals

Connection

Signal	Terminal	Cable Ø9.6 mm, 7-core	Description
GND encoder	-	1	- Supply voltage
U _S encoder	+	2	+ Supply voltage
RxD/TxD-P	B	3	Data wire B (pair 1), bus in
RxD/TxD-N	A	4	Data wire A (pair 1), bus in
RxD/TxD-P	B	5	Data wire B (pair 2), bus out
RxD/TxD-N	A	6	Data wire A (pair 2), bus out
potential earth	⊥	GN/YE	

Configuration

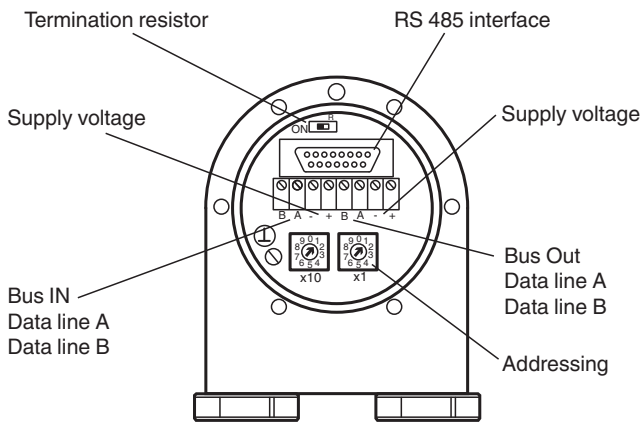

Adjusting the participant address

The participant address can be adjusted with the rotary switches. The address can be defined between 1 and 99, and may only be assigned once.

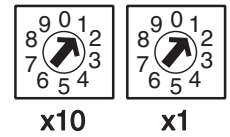

Adjusting the termination resistor

The terminating resistor R_T (220 Ω) can be connected to the circuit by means of the switch:

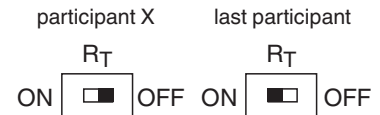

Function Principle

Principle of data transmission

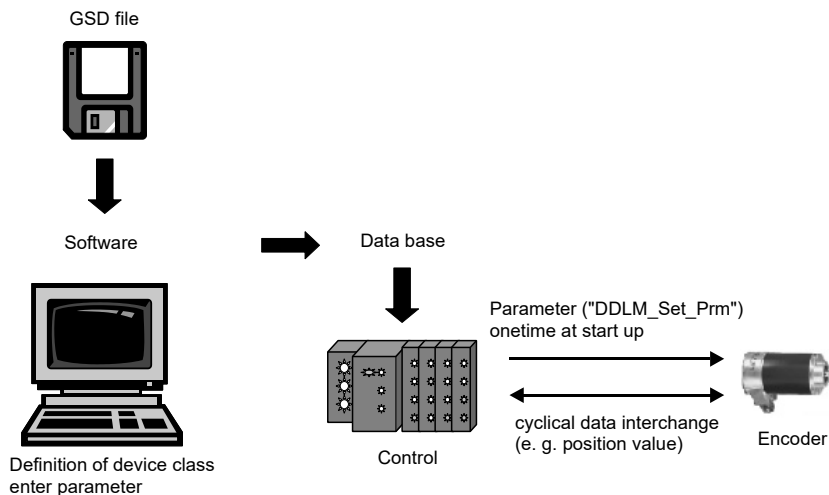

Release date: 2024-10-28 Date of issue: 2024-10-28 Filename: t183642_eng.pdf

Parameterization

Parameter table encoder classes P+F 2.1 and P+F 2.2

Octet number (Byte)	Parameter	Bit number
1...8	PROFIBUS standard parameters	
9	Direction of rotation	0
	Class 2 functionality	1
	Commissioning Diagnostics	2
	Scaling function	3
	Reserved	4
	Reserved	5
	Activate manufacturer specific parameters (Octet 26)	6
	Reserved	7
10 ... 13	Desired measuring steps (reference: Octet 26, Bit 0 and 1)	
14 ... 17	Overall resolution	
18 ... 25	Reserved	
26	Reference for desired measuring steps	0
		1
	Activate commissioning mode	2
	Reduced diagnosis	3
	Reserved	4
	Activate lower software limit switch	5
	Activate upper software limit switch	6
	Activation of the parameters from Octet 27	7
27 ... 30	Lower limit switch	
31 ... 34	Upper limit switch	
35 ... 38	Physical measuring steps	
39	Reserved	0
	Rotary encoder type (singleturn or multiturn)	1
	Reserved	2
	Reserved	3
	Selection of the unit for speed transfer	4
		5
	Reserved	6
	Reserved	7

Type Code

Ordering information

P	S	M	7	8	E	-						0	B	-				
---	---	---	---	---	---	---	--	--	--	--	--	---	---	---	--	--	--	--

Number of singleturn bits
 12 4096
 13 8192
 16 65536

Number of multiturn bits
 12 4096
 14 16384

Housing material
 N Aluminum
 I INOX 1.4404 (AISI 316L)

Output code
 B Binary

Option
 0 None

Exit position
 A Axial
 R Radial

Connection type
 K2 Cable, 7-wire, 2 m
 K5 Cable, 7-wire, 5 m
 DR Terminal compartment, 2 cable glands
 KR Terminal compartment, 1 cable gland, 1 stopping plug

Shaft dimension/flange version
 F5A Recessed hollow shaft Ø14 mm x 35 mm
 F8A Recessed hollow shaft Ø16 mm x 40 mm

Option 1
 E Explosion-proof, standard IP66

Functional principle
 M Multiturn

Shaft version
 S Recessed hollow shaft

Data format
 P PROFIBUS

Installation

Anti-interference measures

The use of highly sophisticated microelectronics requires a consistently implemented anti-interference and wiring concept. This becomes all the more important the more compact the constructions are and the higher the demands are on the performance of modern machines.

The following installation instructions and proposals apply for "normal industrial environments". There is no ideal solution for all interfering environments.

When the following measures are applied, the encoder should be in perfect working order:

- Termination of the serial line with a 120 Ω resistor (between Receive/Transmit and Receive/Transmit) at the beginning and end of the serial line (e. g. the control and the last encoder).
- The wiring of the encoder should be laid at a large distance to energy lines which could cause interferences.
- Cable cross-section of the screen at least 4 mm².
- Cable cross-section at least 0,14 mm².
- The wiring of the screen and 0 V should be arranged radially, if and when possible.
- Do not kink or jam the cables.
- Adhere to the minimum bending radius as given in the data sheet and avoid tensile as well as shearing load.

Operating instructions

Every encoder manufactured by Pepperl+Fuchs leaves the factory in a perfect condition. In order to ensure this quality as well as a faultless operation, the following specifications have to be taken into consideration:

Release date: 2024-10-28 Date of issue: 2024-10-28 Filename: t183642_eng.pdf

- Avoid any impact on the housing and in particular on the encoder shaft as well as the axial and radial overload of the encoder shaft.
- The accuracy and service life of the encoder is guaranteed only, if a suitable coupling is used.
- The operating voltage for the encoder and the follow-up device (e. g. control) has to be switched on and off simultaneously.
- Any wiring work has to be carried out with the system in a dead condition.
- The maximum operating voltages must not be exceeded. The devices have to be operated at extra-low safety voltage.

Notes on connecting the electric screening

The immunity to interference of a plant depends on the correct screening. In this field installation faults occur frequently. Often the screen is applied to one side only, and is then soldered to the earthing terminal with a wire, which is a valid procedure in LF engineering. However, in case of EMC the rules of HF engineering apply.

One basic goal in HF engineering is to pass the HF energy to earth at an impedance as low as possible as otherwise energy would discharge into the cable. A low impedance is achieved by a large-surface connection to metal surfaces.

The following instructions have to be observed:

- Apply the screen on both sides to a "common earth" in a large surface, if there is no risk of equipotential currents.
- The screen has to be passed behind the insulation and has to be clamped on a large surface below the tension relief.
- In case of cable connections to screw-type terminals, the tension relief has to be connected to an earthed surface.
- If plugs are used, metallised plugs only should be fitted (such as sub D plugs with metallised housing). Please observe the direct connection of the tension relief to the housing.

Advantage:	metallised connector,
shield	clamped with the strain
relief	clamp
Disadvantage:	soldering shield on

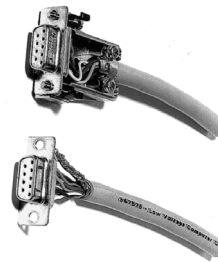

Safety instructions

Please observe the national safety and accident prevention regulations as well as the subsequent safety instructions in these operating instructions when working on encoders.

If failures cannot be remedied, the device has to be shut down and has to be secured against accidental operation.

Repairs may be carried out only by the manufacturer. Entry into and modifications of the device are not permissible.

Tighten the clamping ring only, if a shaft has been fitted in the area of the clamping ring (hollow shaft encoders).

Tighten all screws and plug connectors prior to operating the encoder.

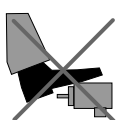

Do not stand on the encoder!



Do not remachine the drive shaft!

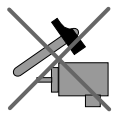

Avoid impact!



Do not remachine the housing!

Release date: 2024-10-28 Date of issue: 2024-10-28 Filename: t183642_eng.pdf