

Absolute rotary encoder

ENA58IL-R***-Profibus



- Recessed hollow shaft
- 30 Bit multiturn
- Free of wear magnetic sampling
- High resolution and accuracy
- Mechanical compatibility with all major encoders with fieldbus interface
- Status LEDs



Function

The ENA58IL series with Profibus interface are high-precision rotary encoders with internal magnetic sampling. The most common mechanical interfaces are available in the ENA58IL series. For the electrical connection, models with connection cover and radial connector outlet or cable outlet or models with axial connector outlet are available. This versatility allows the use of the rotary encoder for all common applications.

Dimensions

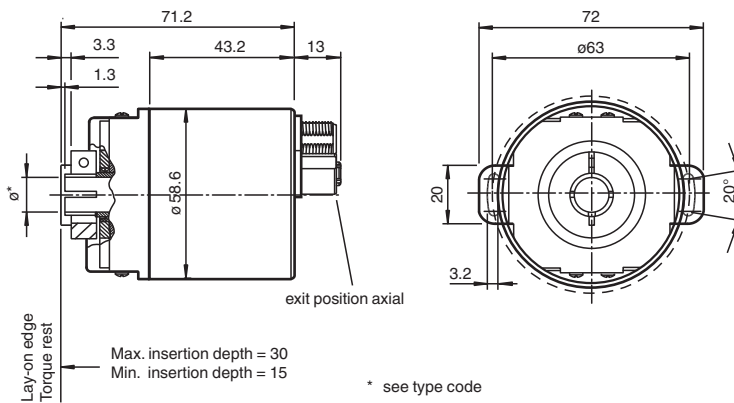

Recessed hollow shaft

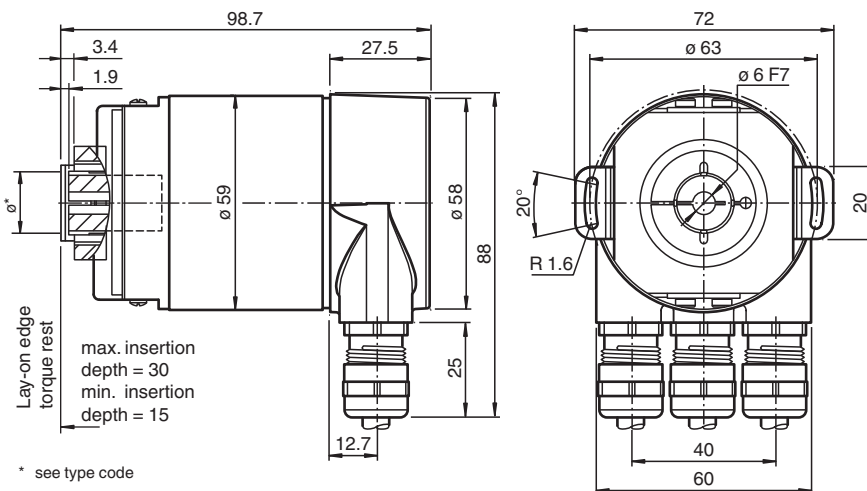

Release date: 2025-04-28 Date of issue: 2025-04-28 Filename: t1183769_eng.pdf

Dimensions

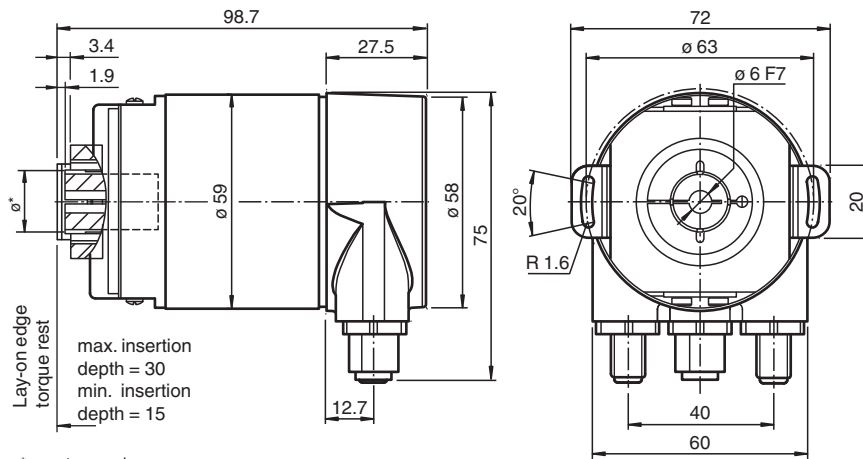

* see type code

Technical Data

General specifications

Detection type	magnetic sampling	
Device type	Absolute rotary encoder	
Linearity error	≤ ± 0.1 °	
UL File Number	E223176 "For use in NFPA 79 Applications only", if UL marking is marked on the product.	

Electrical specifications

Operating voltage	U _B	10 ... 30 V DC
Power consumption	P ₀	approx. 2.5 W
Time delay before availability	t _v	< 1000 ms
Output code	binary code	
Code course (counting direction)	adjustable	

Interface

Interface type	PROFIBUS DP DPV0, DPV1, DPV2	
Resolution		
Single turn	up to 16 Bit	
Multiturn	up to 14 Bit	
Overall resolution	up to 30 Bit	
Transfer rate	≤ 12 MBit/s	

Connection

Connector	For model with axial connector outlet or connection cover with radial connector outlet: Profibus: 1 plug M12 x 1, 5-pin, B-coded; 1 socket M12 x 1, 5-pin, B-coded Supply: 1 plug M12 x 1, 4-pin, A-coded	
Terminal compartment	For model with connection cover with radial cable outlet	

Standard conformity

Degree of protection	DIN EN 60529 , axial connector outlet: IP54 connection cover and shaft seal: IP66/IP67 connection cover, no shaft seal: IP65	
Climatic testing	DIN EN 60068-2-3, no moisture condensation	
Emitted interference	EN 61000-6-4:2007	
Noise immunity	EN 61000-6-2:2005	
Shock resistance	DIN EN 60068-2-27, 100 g, 6 ms	
Vibration resistance	DIN EN 60068-2-6, 10 g, 10 ... 1000 Hz	

Approvals and certificates

UL approval	cULus Listed, General Purpose, Class 2 Power Source , if UL marking is marked on the product.	
-------------	---	--

Ambient conditions

Release date: 2025-04-28 Date of issue: 2025-04-28 Filename: t1183769_eng.pdf

Technical Data

Operating temperature	-40 ... 85 °C (-40 ... 185 °F)
Storage temperature	-40 ... 85 °C (-40 ... 185 °F)
Relative humidity	98 % , no moisture condensation
Mechanical specifications	
Material	
Housing	Zinc plated steel, painted
Flange	Aluminum
Shaft	Stainless steel
Mass	approx. 300 g for model without connection cover approx. 510 g for model with connection cover
Rotational speed	max. 12000 min ⁻¹ for IP54, IP65 max. 3000 min ⁻¹ for IP66/IP67
Moment of inertia	30 gcm ²
Starting torque	< 3 Ncm
Shaft load	
Axial	24 N
Radial	198 N
Angle offset	± 0.9 °
Axial offset	± 0.3 mm static
Radial offset	± 0.5 mm static
Accessories	
Designation	for model without connection cover : Terminator ICZ-TR-V15B, item number 127860 (optional)

Connection

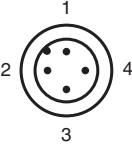
Pin	Male connector M12 x 1, 4-pin, A-coded	Male connector M12 x 1, 5-pin, B-coded	Female connector M12 x 1, 5-pin, B-coded	Terminal	Explanation
1	Supply voltage +U _B	Not connected	+ 5 V for terminator (2P5)	⊥	Ground connection for power supply
2	Not connected	Data wire A, Bus IN	Data wire A, Bus Out	B (left)	Data line B (pair 1), Bus In
3	0 V	Not connected	GND for terminator (2M)	A (left)	Data line A (pair 1), Bus In
4	Not connected	Data wire B, Bus IN	Data wire B, Bus Out	(-)	0 V
5	-	Not connected	Not connected	(+)	10 V ... 30 V
		4	2	B (right)	Data line B (pair 2), Bus Out
				A (right)	Data line A (pair 2), Bus Out
				(-)	0 V
				(+)	10 V ... 30 V
					The supply lines only have to be connected once (regardless to which terminal). The outgoing bus is being uncoupled while the terminal resistor is on.

Operation

Model with axial connector outlet

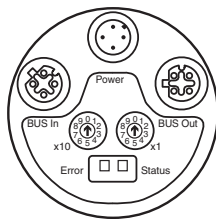

Adjusting the participant address

The participant address can be adjusted with the rotary switches. The address can be defined between 1 and 99, and may only be assigned once.

LED-indicators

LED red	LED green	Meaning
off	off	No voltage supply
on	on	Encoder ready, no configuration data received. possible reasons: - wrong address adjusted - wrong bus wiring
on	flashing	Parameterising or configuration error. Encoder receives data of incorrect length or inconsistent data. possible reason: adjusted encoder resolution exceeds
flashing	on	Encoder ready, no communication with master (i.e. wrong address setting)
on	off	Data timeout (> 40 s). (i.e. data lines interrupted)
off	on	Normal operation, Data Exchange Mode
off	flashing	Installation Mode in Data Exchange Mode.

Release date: 2025-04-28 Date of issue: 2025-04-28 Filename: t183769_eng.pdf

Model with connection cover

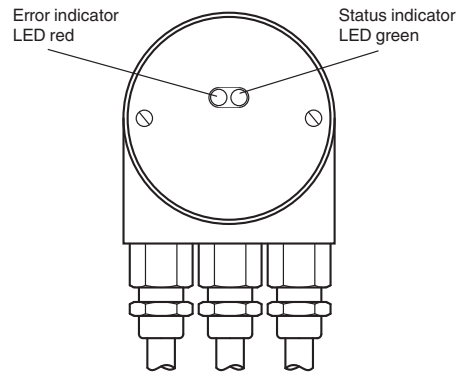
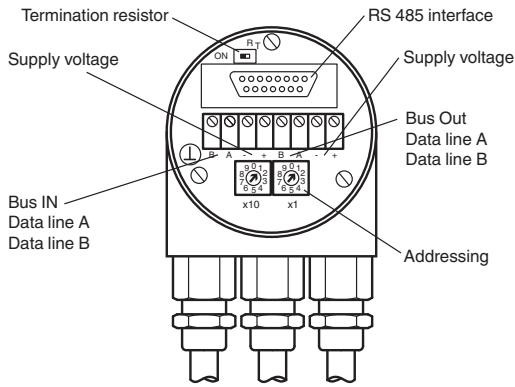

Adjusting the participant address

The participant address can be adjusted with the rotary switches. The address can be defined between 1 and 99, and may only be assigned once.

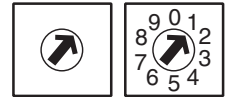

x10

x1

participant X

last participant

Adjusting the termination resistor

The terminating resistor R_T (220 Ω) can be connected to the circuit by means of the switch:



OFF



OFF

LED-indicators

LED red	LED green	Meaning
off	off	No voltage supply
on	on	Encoder ready, no configuration data received. possible reasons: - wrong address adjusted - wrong bus wiring
on	flashing	Parameterising or configuration error. Encoder receives data of incorrect length or inconsistent data. possible reason: adjusted encoder resolution exceeds
flashing	on	Encoder ready, no communication with master (i.e. wrong address setting)
on	off	Data timeout (> 40 s). (i.e. data lines interrupted)
off	on	Normal operation, Data Exchange Mode
off	flashing	Installation Mode in Data Exchange Mode.

Type Code

Model number

E N A 5 8 I L - R D A - B 0 6 -

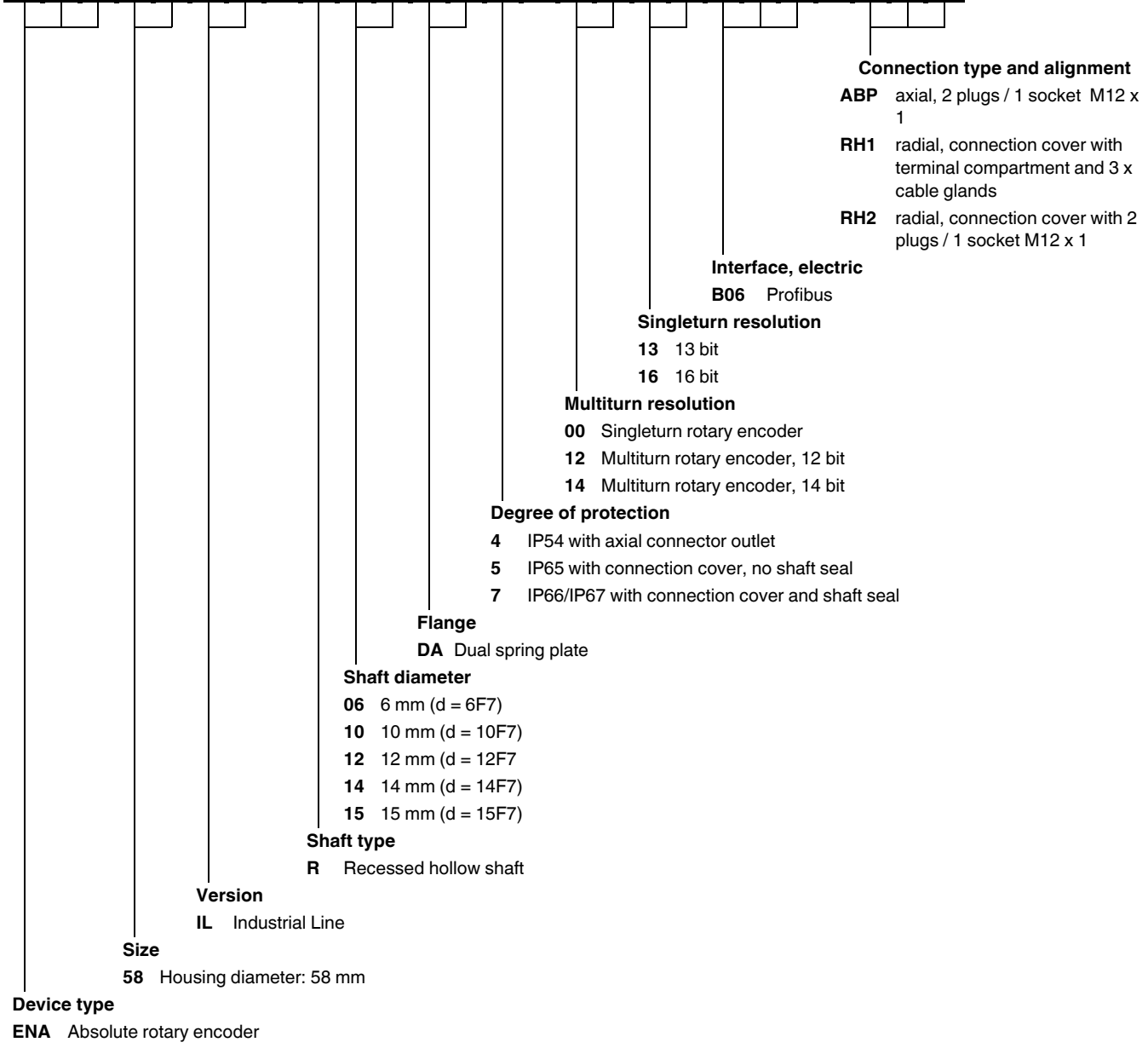

Installation

Anti-interference measures

The use of highly sophisticated microelectronics requires a consistently implemented anti-interference and wiring concept. This becomes all the more important the more compact the constructions are and the higher the demands are on the performance of modern machines.

The following installation instructions and proposals apply for "normal industrial environments". There is no ideal solution for all interfering environments.

When the following measures are applied, the encoder should be in perfect working order:

- Termination of the serial line with a 120 Ω resistor (between Receive/Transmit and Receive/Transmit) at the beginning and end of the serial line (e. g. the control and the last encoder).
- The wiring of the encoder should be laid at a large distance to energy lines which could cause interferences.
- Cable cross-section of the screen at least 4 mm².
- Cable cross-section at least 0,14 mm².
- The wiring of the screen and 0 V should be arranged radially, if and when possible.
- Do not kink or jam the cables.
- Adhere to the minimum bending radius as given in the data sheet and avoid tensile as well as shearing load.

Release date: 2025-04-28 Date of issue: 2025-04-28 Filename: t183769_eng.pdf

Operating instructions

Every encoder manufactured by Pepperl+Fuchs leaves the factory in a perfect condition. In order to ensure this quality as well as a faultless operation, the following specifications have to be taken into consideration:

- Avoid any impact on the housing and in particular on the encoder shaft as well as the axial and radial overload of the encoder shaft.
- The accuracy and service life of the encoder is guaranteed only, if a suitable coupling is used.
- The operating voltage for the encoder and the follow-up device (e. g. control) has to be switched on and off simultaneously.
- Any wiring work has to be carried out with the system in a dead condition.
- The maximum operating voltages must not be exceeded. The devices have to be operated at extra-low safety voltage.

Notes on connecting the electric screening

The immunity to interference of a plant depends on the correct screening. In this field installation faults occur frequently. Often the screen is applied to one side only, and is then soldered to the earthing terminal with a wire, which is a valid procedure in LF engineering. However, in case of EMC the rules of HF engineering apply.

One basic goal in HF engineering is to pass the HF energy to earth at an impedance as low as possible as otherwise energy would discharge into the cable. A low impedance is achieved by a large-surface connection to metal surfaces.

The following instructions have to be observed:

- Apply the screen on both sides to a "common earth" in a large surface, if there is no risk of equipotential currents.
- The screen has to be passed behind the insulation and has to be clamped on a large surface below the tension relief.
- In case of cable connections to screw-type terminals, the tension relief has to be connected to an earthed surface.
- If plugs are used, metallised plugs only should be fitted (such as sub D plugs with metallised housing). Please observe the direct connection of the tension relief to the housing.

Advantage:	metallised connector,
shield	clamped with the strain
relief	clamp
Disadvantage:	soldering shield on

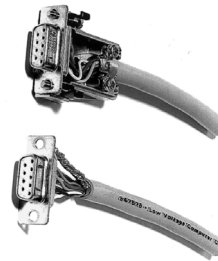

Safety instructions

Please observe the national safety and accident prevention regulations as well as the subsequent safety instructions in these operating instructions when working on encoders.

If failures cannot be remedied, the device has to be shut down and has to be secured against accidental operation.

Repairs may be carried out only by the manufacturer. Entry into and modifications of the device are not permissible.

Tighten the clamping ring only, if a shaft has been fitted in the area of the clamping ring (hollow shaft encoders).

Tighten all screws and plug connectors prior to operating the encoder.

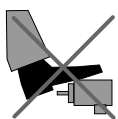

Do not stand on the encoder!



Do not remachine the drive shaft!

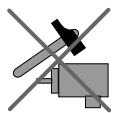

Avoid impact!



Do not remachine the housing!

Release date: 2025-04-28 Date of issue: 2025-04-28 Filename: t183769_eng.pdf