

Multiturn absolute encoder ENA42HD-S***-Analog



- Very small housing
- Sturdy construction
- 4 Bit multiturn
- Models with analog voltage or current output
- Highly shock / vibration and soiling resistant
- Increased shaft load capacity
- Stainless steel housing
- IP69K

Heavy-duty encoder



Function

This absolute encoder with internal magnetic sampling is available with an analog voltage output or an analog current output. Depending on the model, the analog output provides a voltage value or a current value corresponding to the shaft setting. The encoder can be easily programmed by means of electrical inputs.

Dimensions

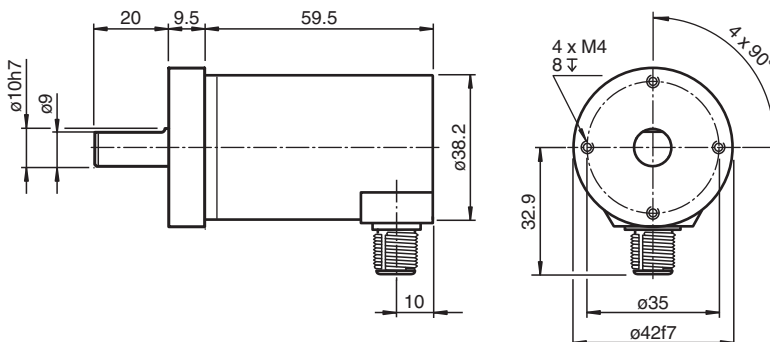
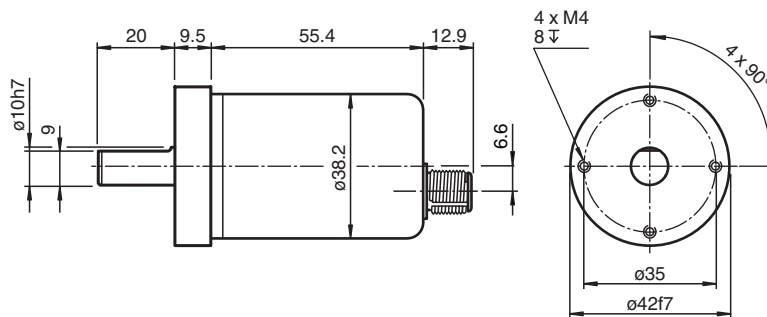

Dimensions

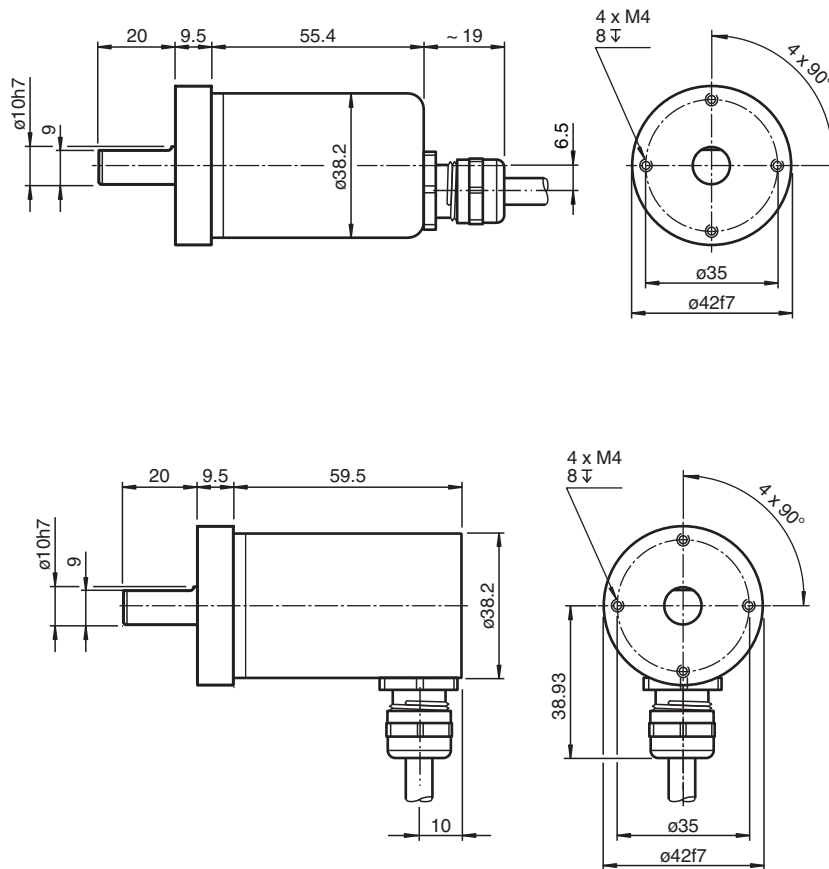

Technical Data

General specifications

Detection type	magnetic sampling	
Device type	Multiturn absolute encoder	
Measurement range	min. 0 ... 22.5 ° max. 16 x 360 °	
Resolution	17 Bit (13 bits/revolution)	
UL File Number	E223176 "For use in NFPA 79 Applications only", if UL marking is marked on the product.	

Electrical specifications

Operating voltage	U_B	8 ... 32 V DC
Current consumption		typ. 15 mA (with voltage output) typ. 20 mA (with current output)

Input 1

Input type	lower limit of measurement range	
Signal voltage		
High	8 ... 32 V DC	
Signal duration	min. 1 s	

Input 2

Input type	upper limit of measurement range	
Signal voltage		
High	8 ... 32 V DC	
Signal duration	min. 1 s	

Analog output

Technical Data

Output type		analog voltage output or analog current output (see type code)
Default setting		rising ramp at ccw rotation
Linearity error		≤ 0.15 %
Load resistor		min. 5000 Ω (with voltage output) , min. 500 Ω (with current output) ; Max. value for supply voltage 8 V. For higher supply voltage lower load resistance can be used.
Connection		
Connector		M12 connector, 5 pin
Cable		2 m fixed cable , 5-wire , screened
Standard conformity		
Degree of protection		IEC/EN 60529
Climatic testing		DIN EN 60068-2-3 , 95 % , no moisture condensation
Emitted interference		EN 61000-6-4:2007
Noise immunity		EN 61000-6-2:2005
Shock resistance		DIN EN 60068-2-27, 300 g, 6 ms
Vibration resistance		DIN EN 60068-2-6, 30 g, 55 ... 2000 Hz
Approvals and certificates		
UL approval		cULus Listed, General Purpose, Class 2 Power Source , if UL marking is marked on the product.
Ambient conditions		
Operating temperature		-40 ... 85 °C (-40 ... 185 °F)
Storage temperature		-40 ... 85 °C (-40 ... 185 °F)
Relative humidity		98 % , no moisture condensation
Mechanical specifications		
Flange		servo flange 42 mm with 4 x Threading M4
Shaft dimensions	Ø x l	10 mm x 20 mm
Degree of protection		IP65 / IP67 / IP68 / IP69k
Material		
Housing		stainless steel 1.4404 / AISI 316L
Flange		stainless steel 1.4404 / AISI 316L
Shaft		Stainless steel 1.4412 / AISI 440B
Mass		approx. 350 g
Rotational speed		max. 6000 min ⁻¹
Moment of inertia		30 gcm ²
Starting torque		< 5 Ncm
Shaft load		
Axial		270 N
Radial		270 N

Connection

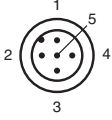
Signal	Wire end	M12 connector
Analog output	Green	1
+V _s (encoder)	Red	2
GND (encoder)	Yellow	3
Set 2	White	4
Set 1	Brown	5
Shielding	Screen	Housing
Pinout	-	

Additional Information

Description of rotary encoder functions

Default Settings

	Lower measuring range limit	Mid measuring range	Upper measuring range limit
Singleturn absolute rotary encoder	0	180°	360°
Multiturn absolute rotary encoder	0	8 x 360°	16 x 360°

Programming Encoders with No Operating Buttons

Scaling the measuring range

Use signal inputs "Set 1" and "Set 2" to scale the measuring range (minimum measuring range: 22.5°).

1. Connect signal inputs "Set 1" and "Set 2" simultaneously to +U_B for 15 seconds. The programming mode is activated now.
2. Turn the rotary encoder shaft to position 1 (lower measuring range limit).
3. Connect signal input "Set 1" to a high-potential source ($+U_{B \min} \leq \text{high potential} \leq +U_{B \max}$) for 1 second.
4. Connect signal input "Set 1" to ground
5. Turn the rotary encoder shaft to position 2 (upper measuring range limit).
6. Connect signal input "Set 2" to a high-potential source ($+U_{B \min} \leq \text{high potential} \leq +U_{B \max}$) for 1 second.
7. Connect signal input "Set 2" to ground

The analog output is now scaled to the programmed measuring range and the rotary encoder will operate in normal mode.

Resetting to the Default Setting

1. Connect the two signal inputs ("Set 1" and "Set 2") to a high-potential source ($+U_{B \min} \leq \text{high potential} \leq +U_{B \max}$) for 1 second. The measuring range is then reset to the default setting.

Analog Output Properties

Depending on its design, the rotary encoder projects the current angular position of the rotary encoder shaft in an analog current or voltage value. The following graphic shows the values the output accepts at the various angular positions:

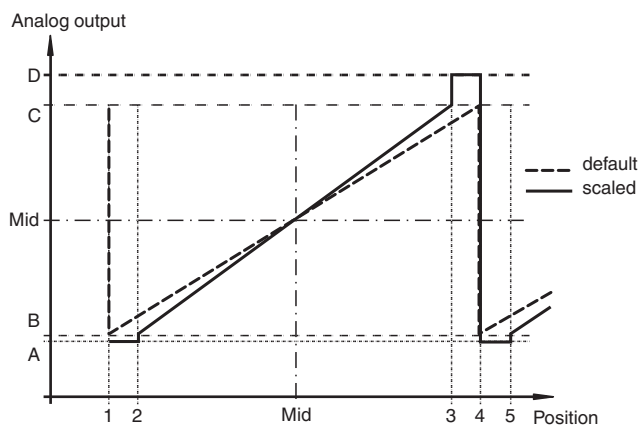

Legend:

Encoder type ¹⁾	Angular position					
	1	2	Mid	3	4	5

Singleturn	Factory default setting	0°	-	180°	-	360°	-
	Scaled	0°	Lower measuring range limit	-	Upper measuring range limit	360°	Lower measuring range limit
Multiturn	Factory default setting	0°	-	2 ⁴ x 180°	-	2 ⁴ x 360°	-
	Scaled ²⁾	0°	Lower measuring range limit	-	Upper measuring range limit	2 ⁿ x 360°	Lower measuring range limit

n = whole number from 1 to 16

1) See model number

2) Overflow at 360°, 720°, 1440°, 2880°, 5760°, etc. depending on the scale set.

Encoder output type	Analog output value				
	A	B	Mid	C	D
4 mA ... 20 mA	3.6 mA	4 mA	12 mA	20 mA	22 mA
0 mA ... 20 mA	-	0 mA	10 mA	20 mA	-

Type Code

Model number

E N A 4 2 H D - S 1 0 S 4 9 - - - 1 3 - - -

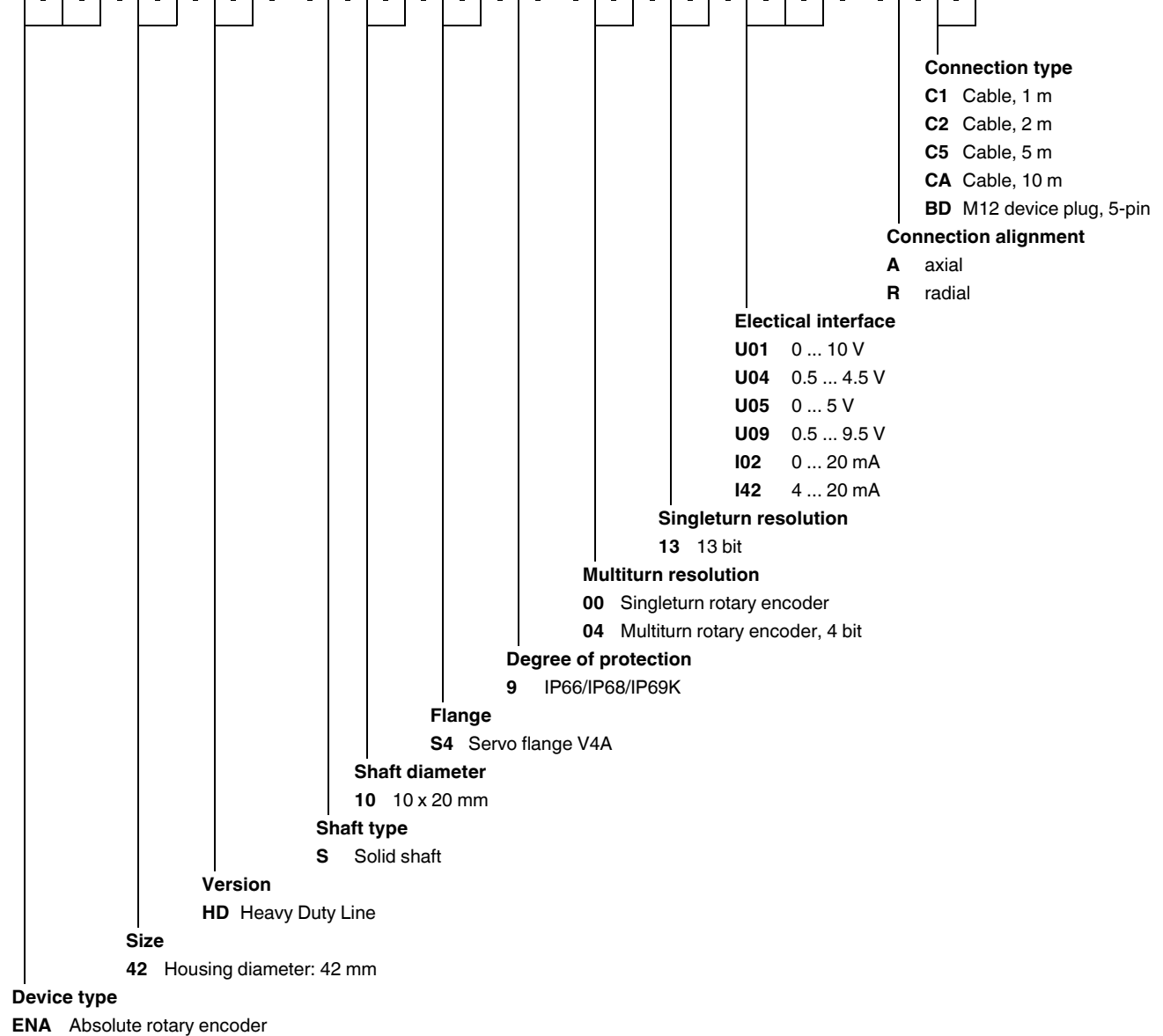

Installation

Anti-interference measures

The use of highly sophisticated microelectronics requires a consistently implemented anti-interference and wiring concept. This becomes all the more important the more compact the constructions are and the higher the demands are on the performance of modern machines.

The following installation instructions and proposals apply for "normal industrial environments". There is no ideal solution for all interfering environments.

When the following measures are applied, the encoder should be in perfect working order:

- Termination of the serial line with a 120 Ω resistor (between Receive/Transmit and Receive/Transmit) at the beginning and end of the serial line (e. g. the control and the last encoder).
- The wiring of the encoder should be laid at a large distance to energy lines which could cause interferences.
- Cable cross-section of the screen at least 4 mm².
- Cable cross-section at least 0,14 mm².
- The wiring of the screen and 0 V should be arranged radially, if and when possible.
- Do not kink or jam the cables.
- Adhere to the minimum bending radius as given in the data sheet and avoid tensile as well as shearing load.

Operating instructions

Release date: 2022-12-12 Date of issue: 2022-12-12 Filename: t187001_eng.pdf

Every encoder manufactured by Pepperl+Fuchs leaves the factory in a perfect condition. In order to ensure this quality as well as a faultless operation, the following specifications have to be taken into consideration:

- Avoid any impact on the housing and in particular on the encoder shaft as well as the axial and radial overload of the encoder shaft.
- The accuracy and service life of the encoder is guaranteed only, if a suitable coupling is used.
- The operating voltage for the encoder and the follow-up device (e. g. control) has to be switched on and off simultaneously.
- Any wiring work has to be carried out with the system in a dead condition.
- The maximum operating voltages must not be exceeded. The devices have to be operated at extra-low safety voltage.

Notes on connecting the electric screening

The immunity to interference of a plant depends on the correct screening. In this field installation faults occur frequently. Often the screen is applied to one side only, and is then soldered to the earthing terminal with a wire, which is a valid procedure in LF engineering. However, in case of EMC the rules of HF engineering apply.

One basic goal in HF engineering is to pass the HF energy to earth at an impedance as low as possible as otherwise energy would discharge into the cable. A low impedance is achieved by a large-surface connection to metal surfaces.

The following instructions have to be observed:

- Apply the screen on both sides to a "common earth" in a large surface, if there is no risk of equipotential currents.
- The screen has to be passed behind the insulation and has to be clamped on a large surface below the tension relief.
- In case of cable connections to screw-type terminals, the tension relief has to be connected to an earthed surface.
- If plugs are used, metallised plugs only should be fitted (such as sub D plugs with metallised housing). Please observe the direct connection of the tension relief to the housing.

Advantage:	metallised connector, shield
	clamped with the strain relief
	clamp
Disadvantage:	soldering shield on

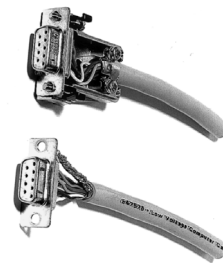

Safety instructions

Please observe the national safety and accident prevention regulations as well as the subsequent safety instructions in these operating instructions when working on encoders.

If failures cannot be remedied, the device has to be shut down and has to be secured against accidental operation. Repairs may be carried out only by the manufacturer. Entry into and modifications of the device are not permissible.

Tighten the clamping ring only, if a shaft has been fitted in the area of the clamping ring (hollow shaft encoders).

Tighten all screws and plug connectors prior to operating the encoder.



Do not stand on the encoder!

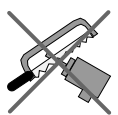

Do not remachine the drive shaft!

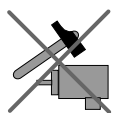

Avoid impact!



Do not remachine the housing!

Release date: 2022-12-12 Date of issue: 2022-12-12 Filename: t187001_eng.pdf