

# Absolute rotary encoder

## ENA58PL-S\*\*\*-CANopen redundant

- Solid shaft
- Up to 30 bit overall resolution
- Redundant CANopen Interface
- Independent photoelectric and magnetic redundant sampling
- Redundant connection option with 2 connectors
- High resolution and accuracy



### Function

The absolute rotary encoder is equipped with an independent optical and magnetic sampling. Optionally, versions with a combined connector or separate connector outlets for each sampling technology are available. Due to the redundancy, the absolute rotary encoder is ideally suited for safety-relevant applications. The integrated CAN bus interface supports all CANopen functions.

Thus the following modes can be programmed to either enabled or disabled:

- Polled mode
- Cyclic mode
- Sync mode

### Dimensions

#### Clamping flange

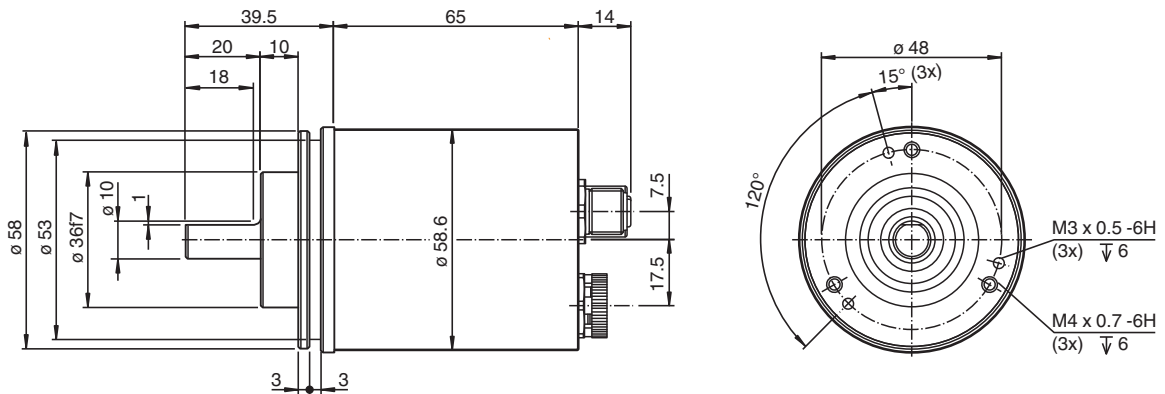

#### Servo flange

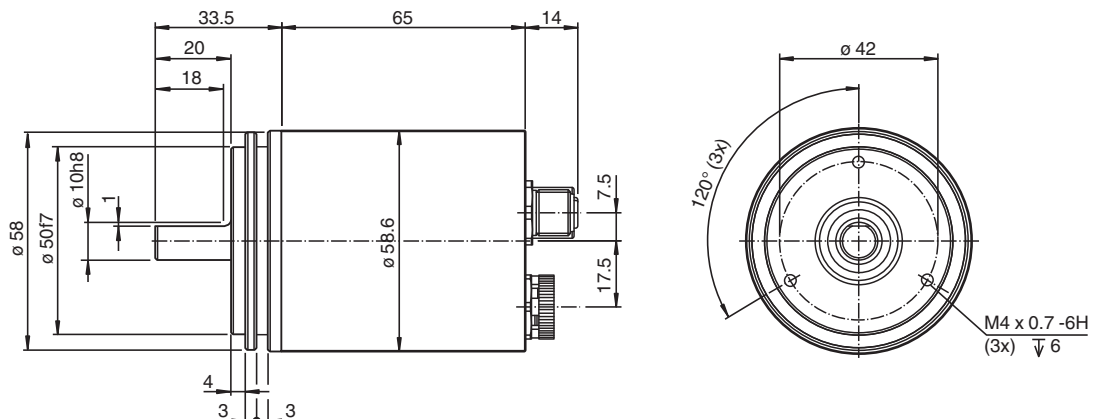

**Dimensions**

Clamping flange

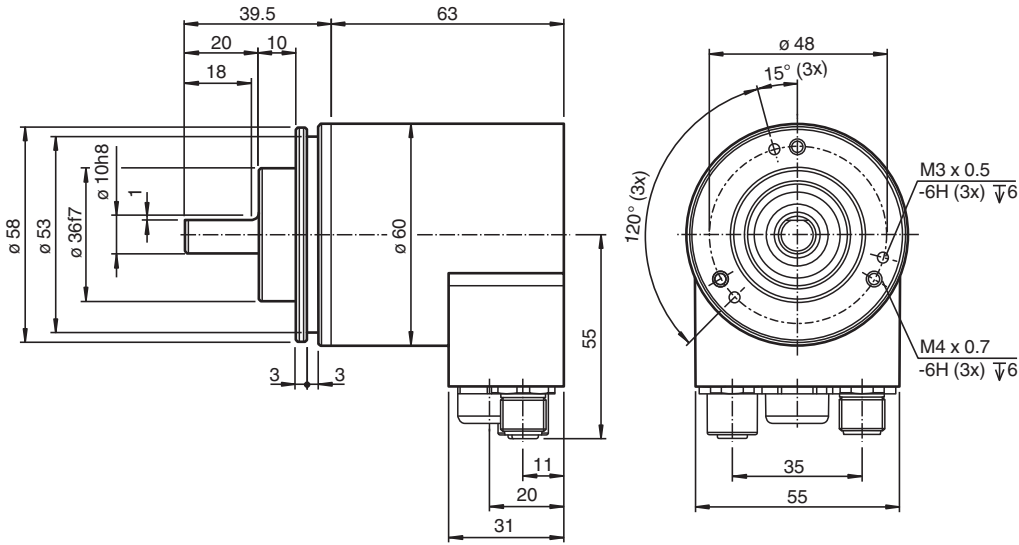

Servo flange

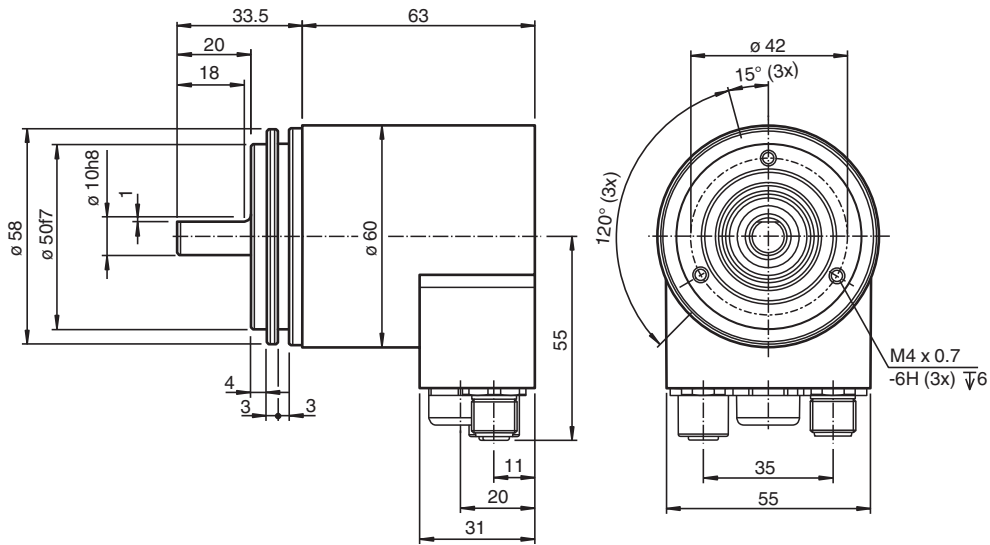

Release date: 2024-02-16 Date of issue: 2024-02-16 Filename: t209188\_eng.pdf

**Technical Data**

General specifications	
Detection type	photoelectric and magnetic sampling
Device type	Absolute rotary encoder
Linearity error	$\leq \pm 0.1^\circ$
UL File Number	E223176 "For use in NFPA 79 Applications only", if UL marking is marked on the product.
Functional safety related parameters	
Performance level (PL)	Suitable for PL d; both channels of the encoder must be connected to a safety PLC and evaluated there.

## Technical Data

Category	Suitable for cat. 3; both channels of the encoder must be connected to a safety PLC and evaluated there.	
MTTF		100 a at 40 °C (based on EN ISO 13849-1)
Mission Time (T <sub>M</sub> )		10 a
<b>Electrical specifications</b>		
Operating voltage	U <sub>B</sub>	10 ... 30 V DC (with galvanic isolation)
Power consumption	P <sub>0</sub>	≤ 3.7 W
Time delay before availability	t <sub>v</sub>	< 250 ms
Output code		binary code
Code course (counting direction)		adjustable
<b>Interface</b>		
Interface type		CANopen
Resolution		
Single turn		up to 16 Bit
Multiturn		up to 14 Bit
Overall resolution		up to 30 Bit
Transfer rate		min. 20 kBit/s , max. 1 MBit/s
Cycle time		≥ 1 ms
Standard conformity		DSP 406
<b>Connection</b>		
Connector		1 plug M12 x 1, 5-pin, A-coded (with connection type BD) 1 plug M12 x 1, 5-pin, A-coded and 1 socket M12 x 1, 5-pin, A-coded (with connection type BN)
<b>Standard conformity</b>		
Degree of protection		DIN EN 60529, IP65 or IP67
Climatic testing		DIN EN 60068-2, no moisture condensation
Emitted interference		EN 61000-6-4
Noise immunity		EN 61000-6-2
Shock resistance		DIN EN 60068-2-27, 100 g, 6 ms
Vibration resistance		DIN EN 60068-2-6, 20 g, 10 ... 1000 Hz
<b>Approvals and certificates</b>		
UL approval		cULus Listed, General Purpose, Class 2 Power Source , if UL marking is marked on the product.
<b>Ambient conditions</b>		
Operating temperature		-40 ... 85 °C (-40 ... 185 °F)
Storage temperature		-40 ... 85 °C (-40 ... 185 °F)
Relative humidity		98 % , no moisture condensation
<b>Mechanical specifications</b>		
Material		
Housing		Aluminum
Flange		Aluminum
Shaft		Stainless steel 1.4305 / AISI 303
Mass		approx. 320 g
Rotational speed		max. 3000 min <sup>-1</sup>
Moment of inertia		30 gcm <sup>2</sup>
Starting torque		< 5 Ncm
Shaft load		
Axial		40 N
Radial		110 N
Dimensions		
Length		55.7 mm
Diameter		58 mm

## Type Code

### Structure of the type code

E	N	A	5	8	P	L	-	S	(1)	(1)	(2)	(2)	(3)	-	(4)	(4)	(5)	(5)	C	R	D	-	(6)	(7)	(7)
---	---	---	---	---	---	---	---	---	-----	-----	-----	-----	-----	---	-----	-----	-----	-----	---	---	---	---	-----	-----	-----

<b>ENA</b>	<b>Device type</b>
ENA	Absolute rotary encoder
<b>58</b>	<b>Size</b>
58	Housing diameter 58 mm
<b>PL</b>	<b>Version</b>
PL	Performance Line
<b>S</b>	<b>Shaft type</b>
S	Solid shaft
<b>(1) (1)</b>	<b>Shaft diameter</b>
06	6 mm
10	10 mm
<b>(2) (2)</b>	<b>Flange</b>
CA	Clamping flange
SA	Servo flange (only with degree of protection B)
<b>(3)</b>	<b>Degree of protection</b>
5	IP65
7	IP67
<b>(4) (4)</b>	<b>Multiturn resolution</b>
12	Multiturn rotary encoder, 12 Bit
14	Multiturn rotary encoder, 14 Bit
<b>(5) (5)</b>	<b>Singleturn resolution</b>
13	13 Bit
16	16 Bit
<b>CRD</b>	<b>Interface, electric</b>
CRD	CANopen redundant, $U_B$ 5 V ... 30 V
<b>(6)</b>	<b>Connection alignment</b>
A	Axial
R	Radial
<b>(7) (7)</b>	<b>Connection type</b>
BD	M12 device plug, 5-pin
BN	M12 device plug, 5-pin and M12 socket, 5-pin

**Connection**

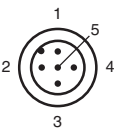
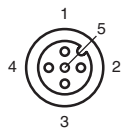
Signal	Device plug M12 x 1, 5-pin, A-coded	Device socket M12 x1, 5-pin, A-coded
	always present	only with connection type BN
CAN GND	1	1
+Vs	2	2
GND	3	3
CAN-High	4	4
CAN-Low	5	5
Shielding	Housing	Housing
Pinout		

The following scheme illustrates the relationships for the electrical connection:

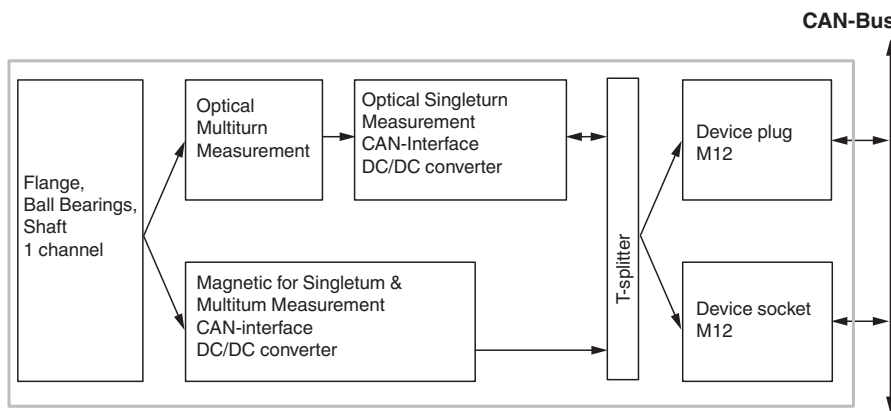

**Indication**

**LED-indicator with dual color LED**

CAN Run (green)	State	Description
Blinking	Pre-Operational	Boot up message is sent, device configuration is possible, device is in CAN state „Pre-Operational“
Single flash	Stopped	The Encoder is in CAN state „Stopped“
On	Operational	The encoder is in CAN state „Operational“
Off		No power supply
Err (red)	State	Description
Off	No error	The Encoder is in operating mode
Flickering	AutoBaudrate	Auto baud mode is active and the encoder tries to find within the time out period a valid CAN message for baud rate measurement
Single flash	Warning limit reached	At least one of the error counters of the CAN controller has reached or exceeded the warning level (too many error frames)
Double flash	Error control event	A guard event (NTM slave or NTM master) or a heartbeat event has occurred
On	Bus off	The CAN controller is in stae bus off. No communication possible anymore. Too many error frames in the network.

**Programming**

**Programmable CAN operating modes**

Mode	Explanation
Polled mode	The connected host requests the current actual position value via a remote transmission request telegram. The absolute encoder reads in the current position, calculates all parameters that have been set and sends back the process actual value through the same CAN identifier.
Cyclic mode	The absolute encoder sends the current actual process value cyclically, without being prompted by the host. The cycle time can be programmed in milliseconds for values between 1 ms and 65536 ms.

Release date: 2024-02-16 Date of issue: 2024-02-16 Filename: I209188\_eng.pdf

Sync mode	After the sync telegram has been received by the host, the absolute encoder sends the current actual process value. If multiple nodes should respond to the sync telegram, the individual nodes report one after the other according to their CAN identifier. There is no programming of an offset time. The sync counter can be programmed so that the rotary encoder does not transmit until after a defined number of sync telegrams.
-----------	--

### Programmable rotary encoder parameters

Parameter	Explanation
Operating parameter	The direction of rotation (complement) can be specified by parameter as the operating parameter. This parameter determines the direction of rotation in which the output code will ascend or descend.
Resolution per revolution	The "Resolution" parameter is used to program the rotary encoder so that a desired number of steps can be implemented in reference to one revolution.
Preset value	The preset value is the desired position value that must be achieved for a specific physical setting of the axis. The preset value parameter is used to set the actual position value to the desired actual process value.
Min. and max. limit switch	A total of two positions can be programmed. The absolute encoder sets one bit to high state in the 32 Bit actual process value if a value falls outside the range between these two positions.
Cam	8 freely programmable cams can be set within the overall resolution. This produces the functionality of a mechanical cam shifting mechanism.