

Absolute rotary encoder

ENA58IL-S***-B17



- Solid shaft
- 30 Bit multiturn
- Free of wear magnetic sampling
- High resolution and accuracy
- Mechanical compatibility with all major encoders with fieldbus interface
- Status LEDs

Absolute rotary encoder with magnetic sampling and PROFINET interface



Function

The absolute rotary encoders with PROFINET IO interface and magnetic sampling can be used in all PROFINET applications. Thanks to the Encoder Profile 4.2 and the IRT mode, they are ideally suited for I4.0 applications.

Dimensions

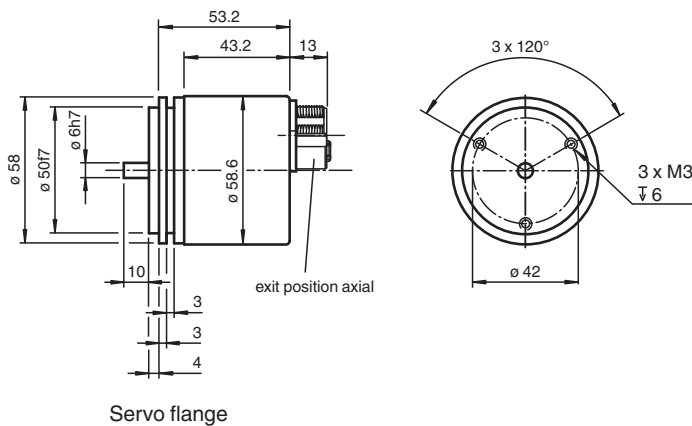
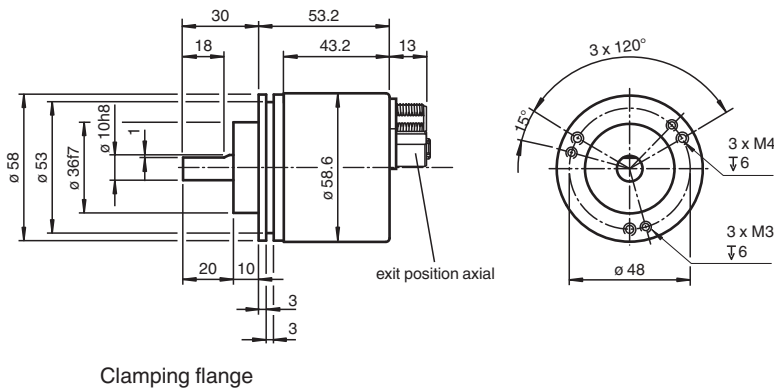

Release date: 2023-12-20 Date of issue: 2023-12-20 Filename: t209827_eng.pdf

Dimensions

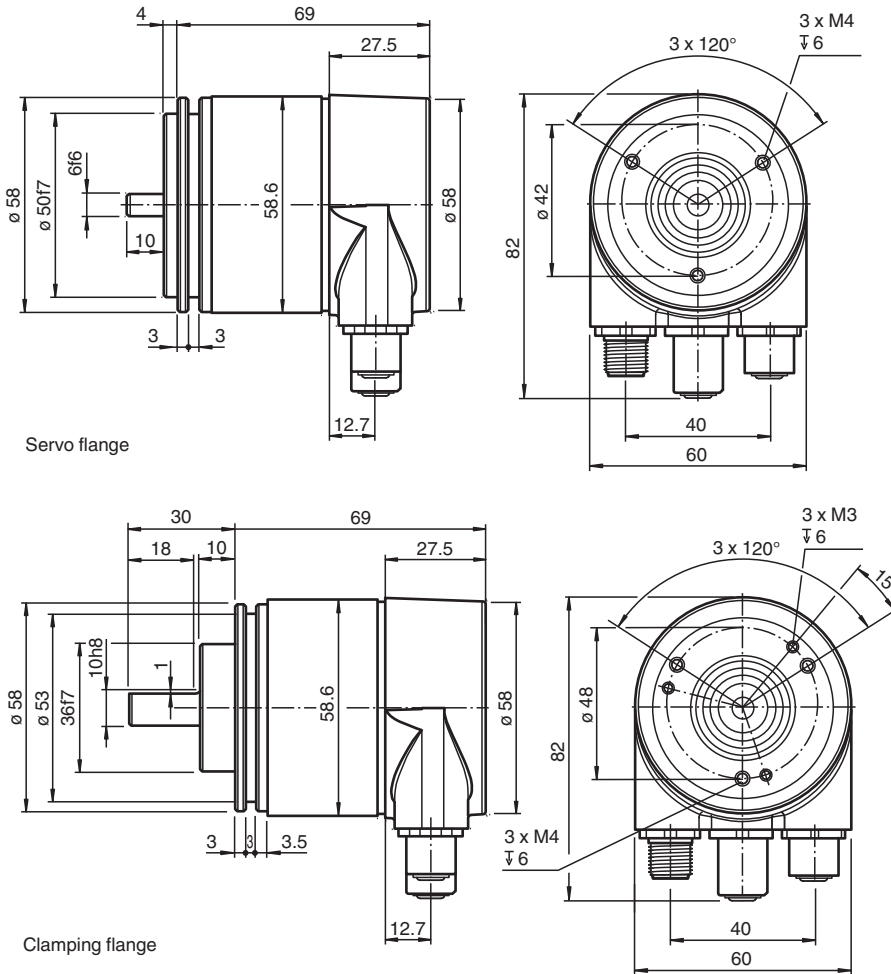

Technical Data

General specifications	
Detection type	magnetic sampling
Device type	Absolute rotary encoder
Linearity error	$\pm 0.1^\circ$
UL File Number	E223176 "For use in NFPA 79 Applications only", if UL marking is marked on the product.
Electrical specifications	
Operating voltage	U_B 10 ... 30 V DC
Power consumption	P_0 approx. 4 W
Time delay before availability	t_v < 15 s
Output code	binary code
Code course (counting direction)	programmable, cw ascending (clockwise rotation, code course ascending) cw descending (clockwise rotation, code course descending)
Interface	
Interface type	PROFINET IO
Device profile	Encoder Profile V4.2
Resolution	
Single turn	up to 16 Bit
Multiturn	up to 14 Bit
Overall resolution	up to 30 Bit
Transfer rate	100 MBit/s
Cycle time	$\geq 250 \mu s$

Release date: 2023-12-20 Date of issue: 2023-12-20 Filename: t209827_eng.pdf

Technical Data

Connection	
Connector	Ethernet: 2 sockets M12 x 1, 4-pin, D-coded Supply: 1 plug M12 x 1, 4-pin, A-coded
Standard conformity	
Degree of protection	DIN EN 60529, IP65, IP66, IP67
Climatic testing	DIN EN 60068-2-3, no moisture condensation
Emitted interference	EN 61000-6-4:2007
Noise immunity	EN 61000-6-2:2005
Shock resistance	DIN EN 60068-2-27, 100 g, 6 ms
Vibration resistance	DIN EN 60068-2-6, 10 g, 10 ... 1000 Hz
Approvals and certificates	
UL approval	cULus Listed, General Purpose, Class 2 Power Source , if UL marking is marked on the product.
Ambient conditions	
Operating temperature	-40 ... 85 °C (-40 ... 185 °F)
Storage temperature	-40 ... 85 °C (-40 ... 185 °F)
Relative humidity	98 % , no moisture condensation
Mechanical specifications	
Material	
Housing	Zinc plated steel, painted
Flange	Aluminum
Shaft	Stainless steel
Mass	approx. 300 g
Rotational speed	max. 12000 min ⁻¹ for IP65 max. 3000 min ⁻¹ for IP66/IP67
Moment of inertia	50 gcm ²
Starting torque	< 5 Ncm
Shaft load	
Axial	40 N
Radial	110 N

Type Code

Structure of the type code

E	N	A	5	8	I	L	-	S	(1)	(1)	(2)	(2)	(3)	-	(4)	(4)	(5)	(5)	B	1	7	-	(6)	(6)	(6)
---	---	---	---	---	---	---	---	---	-----	-----	-----	-----	-----	---	-----	-----	-----	-----	---	---	---	---	-----	-----	-----

ENA	Device type
ENA	Absolute rotary encoder

58	Size
58	Housing diameter 58 mm

IL	Version
IL	Industrial Line

S	Shaft type
S	Solid shaft

(1) (1)	Shaft diameter
06	6 mm
10	10 mm

(2) (2)	Flange
CA	Clamping flange
SA	Servo flange

(3)	Degree of protection
5	IP65
7	IP67

Release date: 2023-12-20 Date of issue: 2023-12-20 Filename: t209827_eng.pdf

Type Code

(4) (4) Multiturn resolution	
00	Singleturn rotary encoder
12	Multiturn rotary encoder, 12 bit
14	Multiturn rotary encoder, 14 bit
(5) (5) Singleturn resolution	
13	13 Bit
16	16 Bit
B17 Interface, electric	
B17	PROFINET
(6) (6) (6) Connection type	
ABP	Axial connection alignment, 2 Sockets / plug M12 x 1
RH2	Radial connection alignment, Bus cover with 2 sockets / plug M12 x 1

Connection

Pin	Male connector M12 x 1, 4-pin, A-coded	Female connector M12 x 1, 4-pin, D-coded
1	Supply voltage +U _B	Tx +
2	-	Rx +
3	0 V	Tx -
4	-	Rx -

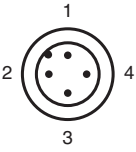
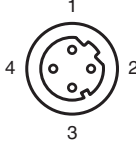
	
---	--

Indication

Diagnostic LEDs

LED	Color	Description for LED = ON
Active1	Yellow	Incoming and outgoing data traffic for port 1
Link1*	Green	Connection to other Ethernet devices on port 1
Active2	Yellow	Incoming and outgoing data traffic for port 2
Link2*	Green	Connection to other Ethernet devices on port 2
Stat1	Green	Status 1, details see table below
Stat2	Red	Status 2, details see table below

* flashes with 2 Hz if engineering identification call is activated and link connection is available

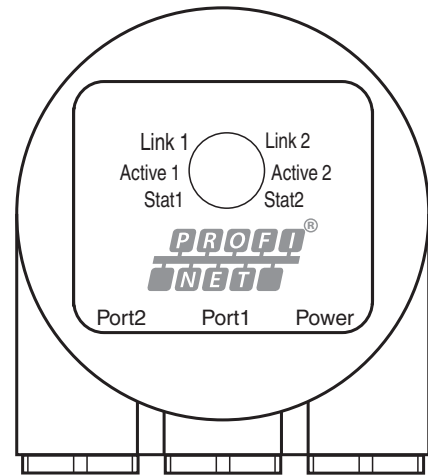

Stat1 (green)	Stat2 (red) bus failure	Meaning	Cause
off	off	No power	
on	on	No connection to another device Criteria: no data exchange	<ul style="list-style-type: none"> • bus disconnected • Master not available / switched off
on	flashes ¹⁾	Parameterization fault, no data exchange Criteria: data exchange correct. However, the slave did not switch to the data exchange mode.	<ul style="list-style-type: none"> • Slave not configured yet or wrong configuration • Wrong station address assigned (but not outside the permitted range) • Actual configuration of the slave differs from the nominal configuration
on	off	Data exchange. Slave and operation ok.	

1) flashing frequency 0.5 Hz for at least 3 seconds

Release date: 2023-12-20 Date of issue: 2023-12-20 Filename: t209827_eng.pdf