

Absolute rotary encoder

ENA58PL-S***-B17

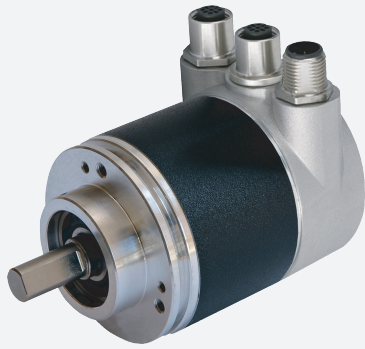

- Solid shaft
- 30 Bit multiturn
- High accuracy due to photoelectric sampling
- High resolution and accuracy
- Mechanical compatibility with all major encoders with fieldbus interface
- Status LEDs

Absolute rotary encoder with photoelectric sampling and PROFINET interface



Function

The absolute encoders with PROFINET IO interface and precious photoelectric sampling can be used in all PROFINET applications. Thanks to the Encoder Profile 4.2 and the IRT mode, they are ideally suited for I4.0 applications.

Dimensions

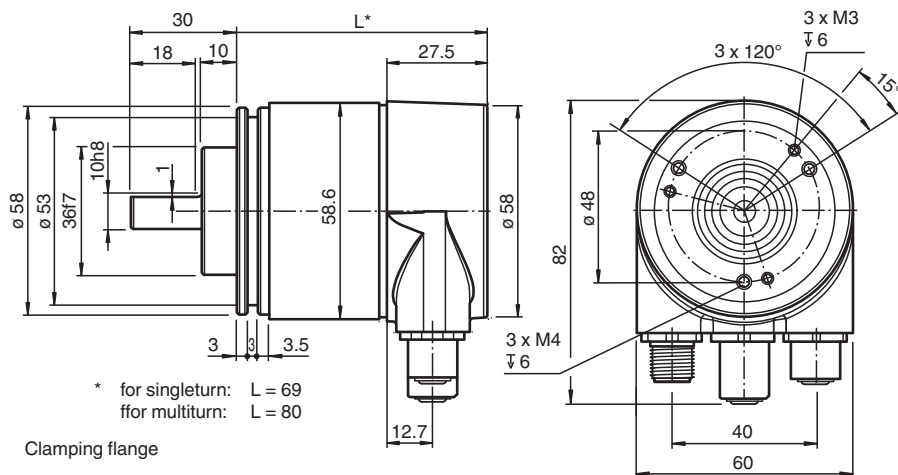
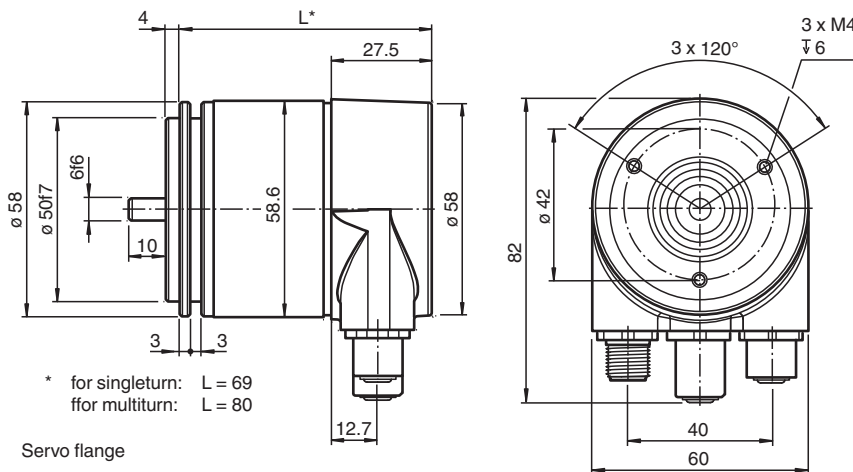

Release date: 2023-12-20 Date of issue: 2023-12-20 Filename: t209829_eng.pdf

Technical Data

General specifications		
Detection type		photoelectric sampling
Device type		Absolute rotary encoder
Linearity error		$\leq \pm 0.02^\circ$ (14 ... 16 bit)
UL File Number		E223176 "For use in NFPA 79 Applications only", if UL marking is marked on the product.
Electrical specifications		
Operating voltage	U_B	10 ... 30 V DC
Power consumption	P_0	approx. 4 W
Time delay before availability	t_v	< 15 s
Output code		binary code
Code course (counting direction)		programmable, cw ascending (clockwise rotation, code course ascending) cw descending (clockwise rotation, code course descending)
Interface		
Interface type		PROFINET IO
Device profile		Encoder Profile V4.2
Resolution		
Single turn		up to 16 Bit
Multiturn		up to 14 Bit
Overall resolution		up to 30 Bit
Transfer rate		100 MBit/s
Cycle time		$\geq 250 \mu\text{s}$
Connection		
Connector		Ethernet: 2 sockets M12 x 1, 4-pin, D-coded Supply: 1 plug M12 x 1, 4-pin, A-coded
Standard conformity		
Degree of protection		DIN EN 60529, Aluminum version: shaft side: IP64 (without shaft seal)/IP66 (with shaft seal) housing side: IP65 Stainless steel version (INOX): completely IP67
Climatic testing		DIN EN 60068-2-3, no moisture condensation
Emitted interference		EN 61000-6-4:2007
Noise immunity		EN 61000-6-2:2005
Shock resistance		DIN EN 60068-2-27, 100 g, 6 ms
Vibration resistance		DIN EN 60068-2-6, 10 g, 10 ... 1000 Hz
Approvals and certificates		
UL approval		cULus Listed, General Purpose, Class 2 Power Source, if UL marking is marked on the product.
Ambient conditions		
Operating temperature		-40 ... 85 °C (-40 ... 185 °F)
Storage temperature		-40 ... 85 °C (-40 ... 185 °F)
Relative humidity		98 %, no moisture condensation
Mechanical specifications		
Material		
Combination 1		housing: powder coated aluminum flange: aluminum shaft: stainless steel
Combination 2 (Inox)		housing: stainless steel 1.4305 / AISI 303 flange: stainless steel 1.4305 / AISI 303 shaft: stainless steel 1.4305 / AISI 303
Combination 3 (A)		housing: stainless steel 1.4404 / AISI 316L flange: stainless steel 1.4404 / AISI 316L shaft: stainless steel 1.4112 / AISI 440B
Mass		approx. 370 g (combination 1) approx. 860 g (combination 2/3)
Rotational speed		max. 12000 min ⁻¹ for IP65 max. 3000 min ⁻¹ for IP66/IP67

Technical Data

Moment of inertia	50 gcm ²
Starting torque	< 5 Ncm
Shaft load	
Axial	40 N
Radial	110 N

Type Code

Structure of the type code

E	N	A	5	8	P	L	-	S	(1)	(1)	(2)	(2)	(3)	-	(4)	(4)	(5)	(5)	B	1	7	-	R	H	2
---	---	---	---	---	---	---	---	---	-----	-----	-----	-----	-----	---	-----	-----	-----	-----	---	---	---	---	---	---	---

ENA	Device type
ENA	Absolute rotary encoder

58	Size
58	Housing diameter 58 mm

PL	Version
PL	Performance Line

S	Shaft type
S	Solid shaft

(1) (1)	Shaft diameter
06	6 mm
10	10 mm

(2) (2)	Flange
CA	Clamping flange, housing and flange in aluminum, shaft in stainless steel
C2	Clamping flange, housing, flange and shaft in stainless steel 1.4305 / AISI303 (V2A)
C4	Clamping flange V4A, housing and flange in stainless steel 1.4404 / AISI316L (V4A), shaft in stainless steel 1.4112 / AISI440B
SA	Servo flange, housing and flange in aluminum, shaft in stainless steel
S2	Servo flange, housing, flange and shaft in stainless steel 1.4305 / AISI303 (V2A)
S4	Servo flange V4A, housing and flange in stainless steel 1.4404 / AISI316L (V4A), shaft in stainless steel 1.4112 / AISI440B

(3)	Degree of protection
5	IP65
7	IP67

(4) (4)	Multiturn resolution
00	Singleturn rotary encoder
12	Multiturn rotary encoder, 12 bit
14	Multiturn rotary encoder, 14 bit

(5) (5)	Singleturn resolution
13	13 Bit
16	16 Bit

B17	Interface, electric
B17	PROFINET

RH2	Connection type
RH2	Radial connection alignment, Bus cover with 2 sockets / plug M12 x 1

Connection

Pin	Male connector M12 x 1, 4-pin, A-coded	Female connector M12 x 1, 4-pin, D-coded
1	Supply voltage +U _B	Tx +
2	-	Rx +
3	0 V	Tx -
4	-	Rx -

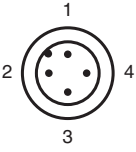
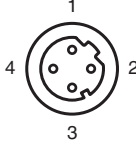
	
---	--

Indication

Diagnostic LEDs

LED	Color	Description for LED = ON
Active1	Yellow	Incoming and outgoing data traffic for port 1
Link1*	Green	Connection to other Ethernet devices on port 1
Active2	Yellow	Incoming and outgoing data traffic for port 2
Link2*	Green	Connection to other Ethernet devices on port 2
Stat1	Green	Status 1, details see table below
Stat2	Red	Status 2, details see table below

* flashes with 2 Hz if engineering identification call is activated and link connection is available

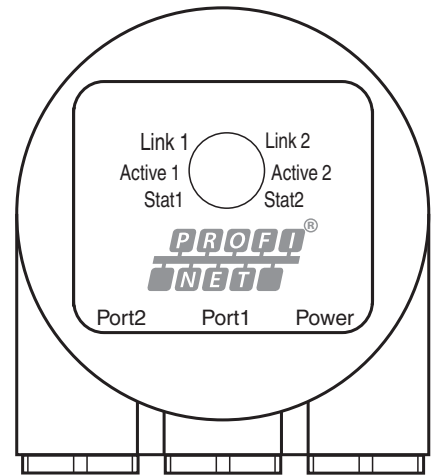

Stat1 (green)	Stat2 (red) bus failure	Meaning	Cause
off	off	No power	
on	on	No connection to another device Criteria: no data exchange	<ul style="list-style-type: none"> • bus disconnected • Master not available / switched off
on	flashes ¹⁾	Parameterization fault, no data exchange Criteria: data exchange correct. However, the slave did not switch to the data exchange mode.	<ul style="list-style-type: none"> • Slave not configured yet or wrong configuration • Wrong station address assigned (but not outside the permitted range) • Actual configuration of the slave differs from the nominal configuration
on	off	Data exchange. Slave and operation ok.	

1) flashing frequency 0.5 Hz for at least 3 seconds

Release date: 2023-12-20 Date of issue: 2023-12-20 Filename: t209829_eng.pdf