



Absolute rotary encoder

ENA58IL-S***-IO-Link

- Absolute rotary encoder of the innovative Performance Line
- Solid shaft
- Position and shaft velocity
- IO-Link Interface for process data, parameterization and diagnosis
- Suitable for condition monitoring
- Measuring range, direction of rotation and switching signals programmable
- Free of wear magnetic sampling
- High resolution and accuracy



IO-Link

Function

Absolute encoders with IO Link are high precision encoders with internal magnetic sampling. The integrated IO Link interface offers an optimal adaption to different applications through parameterization as well as process data transfer and condition monitoring.

Dimensions

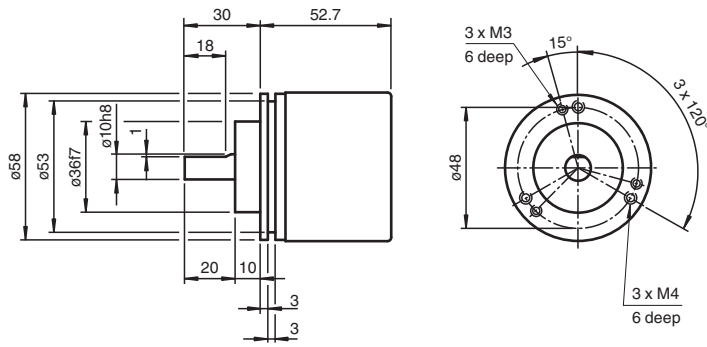

Clamping flange

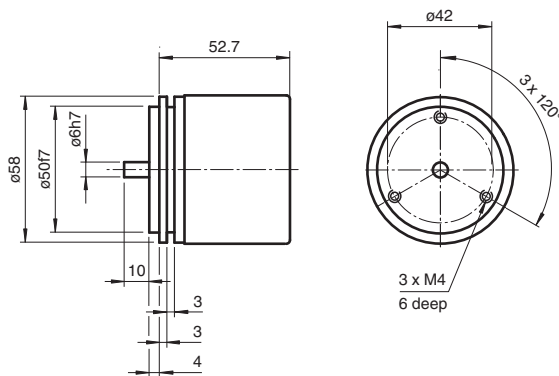

Servo flange

Release date: 2025-04-28 Date of issue: 2025-04-28 Filename: t214148_eng.pdf

Dimensions

Connections

Dimensions in mm

Connector M12

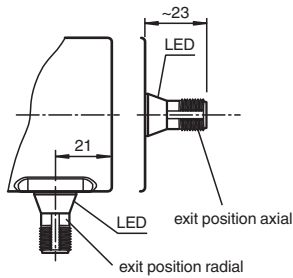

Technical Data

General specifications	
Detection type	magnetic sampling
Device type	Absolute rotary encoder as Performance Line
Measured variable	position shaft velocity Temperature
Linearity error	$\leq \pm 0.1^\circ$
UL File Number	E223176 "For use in NFPA 79 Applications only", if UL marking is marked on the product.
Indicators/operating means	
LED STATUS	LED green flashing with short break (1 Hz) - IO-Link mode
Electrical specifications	
Operating voltage	U_B 18 ... 30 V DC
No-load supply current	I_0 max. 50 mA
Power consumption	P_0 approx. 1.5 W
Time delay before availability	t_v < 1 s
Interface	
Interface type	IO-Link
IO-Link revision	1.1
Device profile	Identification and Diagnosis - I&D
Resolution	
Single turn	up to 16 Bit programmable
Multiturn	up to 15 Bit programmable
Overall resolution	up to 31 Bit programmable
Process data	
	Input 12 Byte - measurement value 4 Byte - resolution 16 Bit - auxiliary measurement value 4 Byte - switching signals 4 Bit - diagnosis signals 2 Bit - status data Output 1 Byte - Trigger 1 Bit
Vendor ID	1 (0x0001)
Device ID	5244419 (0x500603), 5244420 (0x500604), 5244423 (0x500607), 5244424 (0x500608)
Transfer rate	COM3 (230.4 kbits/s)
Min. cycle time	1.5 ms
SIO mode support	no
Compatible master port type	Class A Class B (use 3-pole adapter or 3-wire cable)

Release date: 2025-04-28 Date of issue: 2025-04-28 Filename: t214148_eng.pdf

Technical Data

Connection	
Connector	M12 connector, 5 pin , A-coded
Standard conformity	
Degree of protection	DIN EN 60529, IP65, IP67
Communication interface	IEC 61131-9 / IO-Link V1.1.2
Climatic testing	DIN EN 60068-2-78, no moisture condensation
Emitted interference	EN 61000-6-4:2007
Noise immunity	EN 61000-6-2:2005
Shock resistance	DIN EN 60068-2-27, 100 g, 6 ms
Vibration resistance	DIN EN 60068-2-6, 10 g, 10 ... 1000 Hz
Approvals and certificates	
UL approval	cULus Listed, General Purpose, Class 2 Power Source , if UL marking is marked on the product.
Ambient conditions	
Operating temperature	-40 ... 85 °C (-40 ... 185 °F)
Storage temperature	-40 ... 85 °C (-40 ... 185 °F)
Relative humidity	98 % , no moisture condensation
Mechanical specifications	
Material	
Housing	Zinc plated steel, painted
Flange	Aluminum
Shaft	Stainless steel
Mass	approx. 350 g
Rotational speed	max. 12000 min ⁻¹
Moment of inertia	< 30 gcm ²
Starting torque	< 3 Ncm
Shaft load	
Axial	40 N
Radial	110 N

Connection

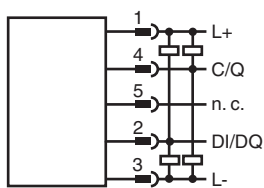

Connection Assignment

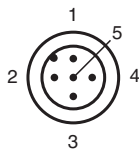

Type Code

Structure of the type code

E	N	A	5	8	I	L	-	S	(1)	(1)	(2)	(2)	(3)	-	(4)	(4)	1	6	-	I	O	-	(5)	(5)	(5)	0	1
---	---	---	---	---	---	---	---	---	-----	-----	-----	-----	-----	---	-----	-----	---	---	---	---	---	---	-----	-----	-----	---	---

ENA	Device type
ENA	Absolute rotary encoder
58	Size
58	Housing diameter 58 mm
IL	Version
IL	Industrial Line / Performance Line
S	Shaft type
S	Solid shaft
(1) (1)	Shaft diameter
06	6 mm
10	10 mm
(2) (2)	Flange
CA	Clamping flange
SA	Servo flange
(3)	Degree of protection
5	IP65
7	IP66, IP67
(4) (4)	Multiturn resolution
00	Singleturn rotary encoder
15	Multiturn rotary encoder, parameterizable up to 15 bit
16	Singleturn resolution
16	16 Bit
IO	Interface, electric
IO	IO-Link
(5) (5) (5)	Connection type
ABP	Axial connection alignment, M12 x 1, 5-pin, A coded
RBD	Radial connection alignment, M12 x 1, 5-pin, A coded
01	Parameterization status
01	P+F factory setting