

# 6100 Series Mini Vent

## EPV-6100-MPM-\*



- Flow rate: 2,000 ... 6,000 l/min
- Intrinsically safe when connected to 6100 control unit
- Compact footprint

6100 series purge and pressurization enclosure protection mini vent



### Function

The Motor Purge Mini Vent pressure relief device exhausts excess pressure from the motor/enclosure. It features a pressure switch that monitors the differential pressure across the vent orifice during the purging cycle. The differential pressure is used to verify the flow through the vent. The pressure switch is connected to the 6100 EPCU. It is intrinsically safe through the galvanic isolation barrier within the 6100 EPCU.

### Operation

Purge Pressure & Flow Rate Table (Mini Vent)

| Model Number                       |           | EPV-6100-MPM-020-XXX  | EPV-6100-MPM-250-XXX              | EPV-6100-MPM-300-XXX  | EPV-6100-MPM-400-XXX              | EPV-6100-MPM-500-XXX  | EPV-6100-MPM-600-XXX              |                       |                                   |                       |                                   |                       |                                   |
|------------------------------------|-----------|-----------------------|-----------------------------------|-----------------------|-----------------------------------|-----------------------|-----------------------------------|-----------------------|-----------------------------------|-----------------------|-----------------------------------|-----------------------|-----------------------------------|
| Purge Flow, L/m                    |           | 2000                  | 2500                              | 3000                  | 4000                              | 5000                  | 6000                              |                       |                                   |                       |                                   |                       |                                   |
| Model Number, EPV-6100-MPM-XXX-XXX | BP (mbar) | Purge Pressure (mbar) | Peak Pressure of Enclosure (mbar) | Purge Pressure (mbar) | Peak Pressure of Enclosure (mbar) | Purge Pressure (mbar) | Peak Pressure of Enclosure (mbar) | Purge Pressure (mbar) | Peak Pressure of Enclosure (mbar) | Purge Pressure (mbar) | Peak Pressure of Enclosure (mbar) | Purge Pressure (mbar) | Peak Pressure of Enclosure (mbar) |
| XXX-010                            | 10        | 11.9                  | 11.9                              | 12.2                  | 12.2                              | 13.0                  | 13.0                              | 13.3                  | 13.3                              | 13.3                  | 13.4                              | 14.0                  | 14.0                              |
| XXX-015                            | 15        | 16.7                  | 16.7                              | 17.3                  | 17.3                              | 17.7                  | 17.7                              | --                    | --                                | --                    | --                                | --                    | --                                |
| XXX-020                            | 20        | 21.2                  | 22.4                              | 23.3                  | 23.3                              | 23.1                  | 23.2                              | 19.5                  | 22.0                              | 18.7                  | 22.0                              | 19.2                  | 22.0                              |
| XXX-030                            | 30        | 33.7                  | 33.7                              | 34.1                  | 34.1                              | 37.2                  | 37.2                              | 34.2                  | 34.2                              | 33.5                  | 34.0                              | 33.5                  | 34.0                              |
| XXX-040                            | 40        | 41.7                  | 42.9                              | 42.0                  | 42.9                              | 44.2                  | 44.7                              | 39.8                  | 42.3                              | 39.9                  | 42.3                              | 39.9                  | 42.3                              |

Note: Breaking and purge pressures shown above are approximate values.

Release date: 2024-11-18 Date of issue: 2024-11-18 Filename: t221366\_eng.pdf

## Dimensions

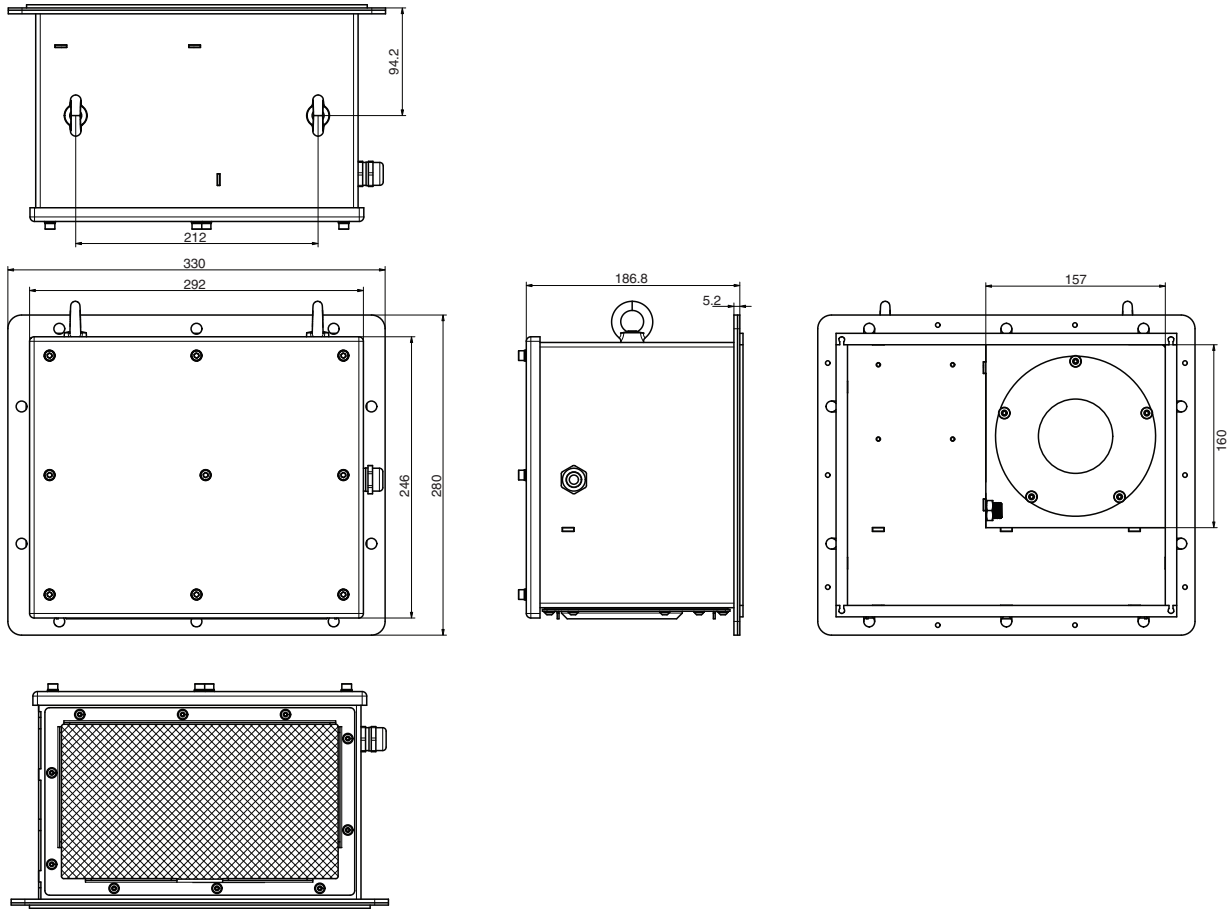

## Technical Data

### General specifications

|                       |              |
|-----------------------|--------------|
| Series                | 6100 Series  |
| System                | Ex pxb Purge |
| Hazardous environment | gas          |

### Electrical specifications

|            |  |
|------------|--|
| Connection |  |
| Power      | Intrinsically safe connection to the 6100 control unit |
| Signal     | 2-wire intrinsically safe pressure switch              |
| Connection | 2-wire   |

### Pneumatic parameters

|                                    |   |
|------------------------------------|---|
| Protective gas supply              | Clean air or inert gas  |
| Safe pressure                      | 0.625 mbar [0.25 in wc / 6.4 mm wc]   |
| Enclosure pressure                 | 0 ... 50 mbar (0 ... 20.1 in wc / 0 ... 510.5 mm wc)  |
| Flow rate for leakage compensation | depends on enclosure seal<br>based on completely sealed enclosure   |
| Breaking pressure                  | Approx. 10 mbar (4.0 in wc)<br>Approx. 15 mbar (6.0 in wc)<br>Approx. 20 mbar (8.0 in wc)<br>Approx. 30 mbar (12.1 in wc)<br>Approx. 40 mbar (16.1 in wc) |

### Directive conformity

|                               |                 |
|-------------------------------|-----------------|
| Electromagnetic compatibility |                 |
| Directive 2014/30/EU          | EN 61326-1:2013 |
| RoHS                          |                 |

## Technical Data

|  |  |
|--|--|
| Directive 2011/65/EU (RoHS)                                    | EN 50581:2012  |
| <b>Ambient conditions</b>                                      |  |
| Ambient temperature  | -20 ... 60 °C (-4 ... 140 °F)  |
| Storage temperature  | -20 ... 80 °C (-4 ... 176 °F)  |
| Relative humidity  | 5 ... 95 %, noncondensing  |
| Vibration resistance   | EN 60068-2-6   |
| Impact resistance  | EN 60068-2-27  |
| <b>Mechanical specifications</b>                               |  |
| Material   | 316L stainless steel (housing)   |
| Installation   | -gravity dependent<br>-air outlet, screen side must be facing down   |
| Mass   | 9 kg (20 lb)   |
| <b>Data for application in connection with hazardous areas</b> |  |
| Certificate  | CML 19 ATEX 1425X  |
| Marking  | ⊕ II2G Ex db eb ib [ib Gb][pxb Gb] IIC T4 Gb   |
| Directive conformity   |  |
| Directive 2014/34/EU   | EN IEC 60079-0:2018<br>EN 60079-1:2014<br>EN 60079-2:2014<br>EN 60079-7:2015<br>EN 60079-11:2012   |
| <b>International approvals</b>                                 |  |
| IECEx approval   | IECEx CML 19.0156X<br>Ex db eb ib [ib Gb][pxb Gb] IIC T4 Gb  |
| <b>General information</b>                                     |  |
| Supplementary information                                      | EC-Type Examination Certificate, Statement of Conformity, Declaration of Conformity, Attestation of Conformity and instructions have to be observed where applicable. For information see <a href="http://www.pepperl-fuchs.com">www.pepperl-fuchs.com</a> .<br>Supplemental Standards : EN 61010-1:2010 |

## Type Code

Structure of the type code

|          |                              |
|----------|------------------------------|
| (1)      |                              |
| <b>1</b> | <b>Model</b>                 |
| EPV      | Enclosure Protection Vent    |
| <b>2</b> | <b>Series</b>                |
| 6100     | 6100 Series                  |
| <b>3</b> | <b>Device Variant</b>        |
| MPM      | Ex pxb Motor Purge Mini-Vent |
| <b>4</b> | <b>Flow Rate</b>             |
| 020      | 2,000 l/min*                 |
| 025      | 2,500 l/min*                 |
| 030      | 3,000 l/min*                 |
| 040      | 4,000 l/min                  |
| 050      | 5,000 l/min                  |
| 060      | 6,000 l/min                  |
| ZZZ      | Custom option                |
| <b>5</b> | <b>Breaking Pressure</b>     |
| 010      | 10 mbar                      |
| 015      | 15 mbar                      |
| 020      | 20 mbar                      |
| 030      | 30 mbar                      |
| 040      | 40 mbar*                     |
| ZZZ      | Custom option                |

\*Lower flows are not available at higher breaking pressures.